



2023 **ARIYA**
OWNER'S MANUAL
and MAINTENANCE INFORMATION

For your safety, read carefully and keep in this vehicle.

OWNER'S MANUAL SUPPLEMENT

The information contained within this supplement revises or adds to the "Towing a Trailer" section of the "Technical and consumer information" section in the 2023–2024 Nissan Ariya Owner's Manual.

Read carefully and keep in the vehicle.

Printing: November 2023

Publication No. SU24E0 0FE0U0



TOWING A TRAILER (2WD models)

WARNING

- **Do not tow with 2WD models. Serious damage could occur to your EV system, axle or other parts, and may lead to a collision, which could result in serious personal injury or death.**
- **The Lifestyle Receiver cannot be used for towing a trailer. Only use the Lifestyle Receiver for receiver mounted accessories that meet the below requirements.**
 - **The maximum allowable load is 100 lbs. (45 kg) including the weight of the installed accessory carrier.**
 - **Do not exceed allowable cargo weight capacity of your vehicle.**
- **Failure to use the Lifestyle Receiver as intended can result in serious injury or death.**

Do not tow a trailer with your vehicle with the Lifestyle Receiver (if so equipped). The Lifestyle Receiver should be used for receiver-mounted accessories only. The Lifestyle Receiver is designed for carrying bikes, snow boards/skis, camping gear and various other bulky items.

Foreword

This manual was prepared to help you understand the operation and maintenance of your vehicle so that you may enjoy many miles of driving pleasure. Please read through this manual before operating your vehicle.

A separate Warranty Information Booklet explains details about the warranties covering your vehicle. The "Maintenance and schedules" section of this manual explains details about maintaining and servicing your vehicle. Additionally, a separate Customer Care and Lemon Law Information Booklet (U.S. only) will explain how to resolve concerns you may have with your vehicle, as well as reference your rights under applicable law.

When you require any service or have any questions, a NISSAN certified ARIYA dealer will be glad to assist you with the extensive resources available to them. In addition to factory installed options, your vehicle may also be equipped with additional accessories installed by NISSAN or by your NISSAN certified ARIYA dealer prior to delivery. It is important that you familiarize yourself with all disclosures, warnings, cautions and instructions concerning proper use of such accessories prior to operating the vehicle and/or accessory. It is recommended you see a

NISSAN certified ARIYA dealer for details concerning the particular accessories with which your vehicle is equipped.

Your NISSAN certified ARIYA dealer knows your vehicle best. When you require any service or have any questions, we will be glad to assist you with the extensive resources available to us.

READ FIRST — THEN DRIVE SAFELY

Before driving your vehicle, read your Owner's Manual carefully. This will ensure familiarity with controls and maintenance requirements, assisting you in the safe operation of your vehicle.



WARNING

IMPORTANT SAFETY INFORMATION REMINDERS!

Follow these important driving rules to help ensure a safe and comfortable trip for you and your passengers!

- **NEVER** drive under the influence of alcohol or drugs.
- **ALWAYS** observe posted speed limits and never drive too fast for conditions.
- **ALWAYS** give your full attention to driving and avoid using vehicle

features or taking other actions that could distract you.

- **ALWAYS** use your seat belts and appropriate child restraint systems. **Pre-teen children should be seated in the rear seat.**
- **ALWAYS** provide information about the proper use of vehicle safety features to all occupants of the vehicle.
- **ALWAYS** review this Owner's Manual for important safety information.

On-pavement and off-road driving

This vehicle will handle and maneuver differently from an ordinary passenger car because it has a higher center of gravity. As with other vehicles with features of this type, failure to operate this vehicle correctly may result in loss of control or an accident. Be sure to read "Avoiding collision and rollover" and "Driving safety precautions" in the "5. Starting and driving" section of this manual.

MODIFICATION OF YOUR VEHICLE

This vehicle should not be modified. Modification could affect its performance, safety or durability, and may even violate governmental regulations. In addition, damage or performance problems resulting from modification may not be covered under NISSAN warranties.



WARNING

Installing an aftermarket On-Board Diagnostic (OBD) plug-in device that uses the port during normal driving, for example remote insurance company monitoring, remote vehicle diagnostics, telematics or EV system reprogramming, may cause interference or damage to vehicle systems. We do not recommend or endorse the use of any aftermarket OBD plug-in devices, unless specifically approved by NISSAN. The vehicle warranty may not cover damage caused by any aftermarket plug-in device.

WHEN READING THE MANUAL

This manual includes information for all features and equipment available on this model. Features and equipment in your vehicle may vary depending on model, trim level, options selected, order, date of production, region or availability. Therefore, you may find information about features or equipment that are not included or installed on your vehicle.

All information, specifications and illustrations in this manual are those in effect at the time of printing. NISSAN reserves the right to change specifications, performance, design or component suppliers without notice and without obligation. From time to time, NISSAN may update or revise this manual to provide Owners with the most accurate information currently available. Please carefully read and retain with this manual all revision updates sent to you by NISSAN to ensure you have access to accurate and up-to-date information regarding your vehicle. Current versions of vehicle Owner's Manuals and any updates can also be found in the Owner section of the NISSAN website at <https://owners.nissanusa.com/owners/navigation/manualsGuide>. If you have questions concerning any information in your Owner's Manual, contact

NISSAN Consumer Affairs. See the NISSAN CUSTOMER CARE PROGRAM page in this Owner's Manual for contact information.

IMPORTANT INFORMATION ABOUT THIS MANUAL

You will see various symbols in this manual. They are used in the following ways:



WARNING

This is used to indicate the presence of a hazard that could cause death or serious personal injury. To avoid or reduce the risk, the procedures must be followed precisely.



CAUTION

This is used to indicate the presence of a hazard that could cause minor or moderate personal injury or damage to your vehicle. To avoid or reduce the risk, the procedures must be followed carefully.

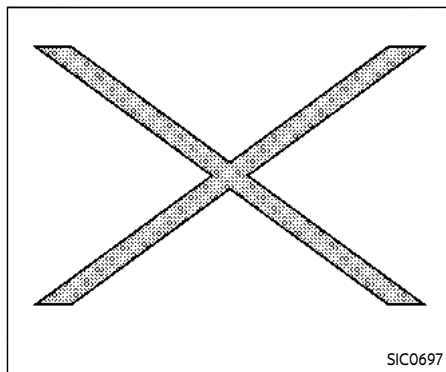

If you see the symbol above, it means **“Do not do this”** or **“Do not let this happen”**.

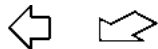

If you see a symbol similar to those above in an illustration, it means the arrow points to the front of the vehicle.



Arrows in an illustration that are similar to those above indicate movement or action.



Arrows in an illustration that are similar to

those above call attention to an item in the illustration.

CALIFORNIA PERCHLORATE ADVISORY

Some vehicle parts, such as lithium batteries, may contain perchlorate material. The following advisory is provided: “Perchlorate Material - special handling may apply, see www.dtsc.ca.gov/hazardouswaste/perchlorate.”

© 2022 NISSAN MOTOR CO., LTD.

All rights reserved. No part of this Owner's Manual may be reproduced or stored in a retrieval system, or transmitted in any form, or by any means, electronic, mechanical, photocopying, recording or otherwise, without the prior written permission of Nissan Motor Co., Ltd.

NISSAN CUSTOMER CARE PROGRAM

NISSAN CARES ...

Both NISSAN and your NISSAN certified ARIYA dealer are dedicated to serving all your automotive needs. Your satisfaction with your vehicle and your NISSAN certified ARIYA dealer are our primary concerns. Your NISSAN certified ARIYA dealer is always available to assist you with all your automobile sales and service needs.

However, if there is something that your NISSAN certified ARIYA dealer cannot assist you with or you would like to provide NISSAN directly with comments or questions, please contact the NISSAN Consumer Affairs Department using our toll-free number:

For U.S. customers
1-800-NISSAN-1
(1-800-647-7261)

For Canadian customers
1-800-387-0122

The Consumer Affairs Department will ask for the following information:

- Your name, address, and telephone number
- Vehicle identification number (attached to the top of the instrument panel on the driver's side)
- Date of purchase
- Current odometer reading
- Your NISSAN certified ARIYA dealer's name
- Your comments or questions

OR

You can write to NISSAN with the information at:

For U.S. customers
Nissan North America, Inc.
Consumer Affairs Department
P.O. Box 685003
Franklin, TN 37068-5003
or via e-mail at:
nnaconsumeraffairs@nissan-usa.com

For Canadian customers
Nissan Canada Inc.
5290 Orbitor Drive
Mississauga, Ontario L4W 4Z5
or via e-mail at:
information.centre@nissancanada.com

If you prefer, visit us at:

www.nissanusa.com (for U.S. customers)
or

www.nissan.ca (for Canadian customers)

We appreciate your interest in NISSAN and thank you for buying a quality NISSAN vehicle.

NISSAN SOFTWARE LICENSE

- Your vehicle includes physical parts and/or physical components of such parts on which software and/or firmware ("Software") is embedded or installed. Additionally, updates to Software may be made available by Nissan for download and installation by owners from time to time as determined by Nissan in its sole discretion. Such Software, and all updates thereto, including updates delivered by Nissan to your vehicle over the air (collectively "Updates"), are licensed, and not sold, to you. A portion of the Software may contain or consist of open source software, which may be used under the terms and conditions of the specific license under which the open source software is distributed. For other Software, including Software for which there is no separate license agreement between you and the manufacturer or owner of the Software, the terms and conditions governing your right to use and the use of the installed Software, including any Updates, applications, services, and content provided for or through the Software, are set forth in the End User License Agreement found at <https://www.nissanusa.com/owners/ownership>. Your use of the Software, including any Updates, constitutes consent to the End User License Agreement's terms and conditions.
- PLEASE NOTE: The End User License Agreement contains an arbitration clause. You may opt out of this arbitration clause within 30 days of the date of your vehicle purchase by sending a signed, written notice to Nissan at the following address:
Nissan North America, Inc.
Consumer Affairs Department
P.O. Box 685003
Franklin, TN 37068-5003
- Please refer to Software Update in the "2. Getting Started" section of the NissanConnect Owner's Manual for information about installing Over-the-Air Updates. For questions or assistance concerning installation of any Over-the-Air Updates, you may contact Nissan Consumer Affairs at 1-800-333-0207. You may also choose to visit a Nissan dealer for assistance - charges may apply.

Table of Contents

Illustrated table of contents	0
Overview	EV
Charging	CH
Safety – Seats, seat belts and supplemental restraint system	1
Instruments and controls	2
Pre-driving checks and adjustments	3
Monitor, heater, air conditioner, audio and phone systems	4
Starting and driving	5
In case of emergency	6
Appearance and care	7
Do-it-yourself	8
Maintenance and schedules	9
Technical and consumer information	10
Index	11

0 Illustrated table of contents

Seats, seat belts and Supplemental Restraint System (SRS)	0-2	Cockpit	0-6
Exterior front	0-3	Instrument panel	0-7
Exterior rear	0-4	Meters and gauges	0-8
Passenger compartment	0-5	Motor compartment	0-9
		Warning and indicator lights	0-10

SEATS, SEAT BELTS AND SUPPLEMENTAL RESTRAINT SYSTEM (SRS)

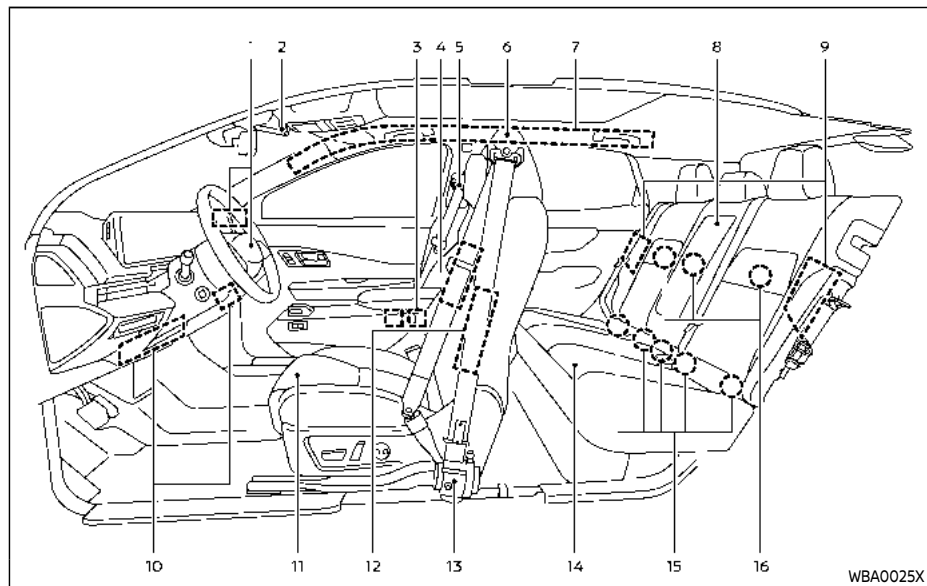

- | | |
|--|---|
| 1. Supplemental front-impact air bags (P.1-48) | 5. Seat belts (P.1-14) |
| 2. Front passenger air bag status light (P.1-48) | 6. Head restraints/headrests (P.1-10) |
| 3. Front central seat-mounted side-impact supplemental air bag* (P.1-48) | 7. Roof-mounted curtain side-impact and rollover supplemental air bags (P.1-48) |
| 4. Front passenger seat-mounted side-impact supplemental air bag* (P.1-48) | 8. Rear armrest* (P.1-9) |
| | 9. Rear outboard seat-mounted side-impact supplemental air bags (P.1-48) |

10. Driver and front passenger supplemental knee air bags (P.1-48)
 11. Front seats (P.1-3)
 12. Front seat-mounted side-impact supplemental air bags* (P.1-48)
 13. Seat belt pretensioners (P.1-67)
 14. Rear seats (P.1-7)
 - Child restraints (P.1-26)
 15. LATCH (Lower Anchors and Tethers for Children) system (for rear seats) (P.1-28)
 16. Child restraint anchor points (for top tether strap) (P.1-39)
- *: if so equipped

EXTERIOR FRONT

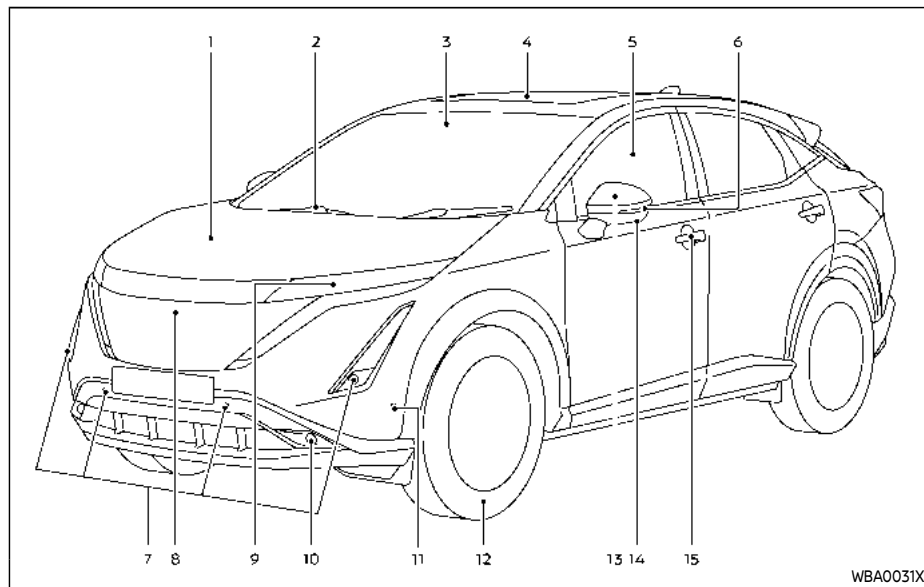

10. Front fog lights* (P.2-69)
 11. Sonar sensors (side)*
 - ProPILOT Park* (P.5-165)
 12. Tires
 - Wheels and tires (P.8-18, P.10-5)
 - Emergency tire puncture repair kit (P.6-4)
 - Tire Pressure Monitoring System (TPMS) (P.2-17, P.5-5)
 13. Outside mirrors (P.3-38)
 14. Side view camera* (P.4-11)
 15. Doors
 - Keys (P.3-2)
 - Door locks (P.3-4)
 - Intelligent Key system (P.3-6)
 - Security system (P.2-55)
- *: if so equipped

1. Hood (P.3-20)
2. Windshield wiper and washer
 - Switch operation (P.2-56)
 - Window washer fluid (P.8-10)
3. Front camera* (P.2-64, P.5-40, P.5-44, P.5-49, P.5-63, P.5-82, P.5-120)
4. Moonroof* (P.2-95)
5. Power windows (P.2-91)
6. Side turn signal light* (P.2-68)
7. Sonar sensors (center and corner)
 - Sonar system (P.5-160)
 - ProPILOT Park* (P.5-165)
8. Front view camera* (P.4-11)
9. Headlights and turn signal lights (P.2-61)

EXTERIOR REAR

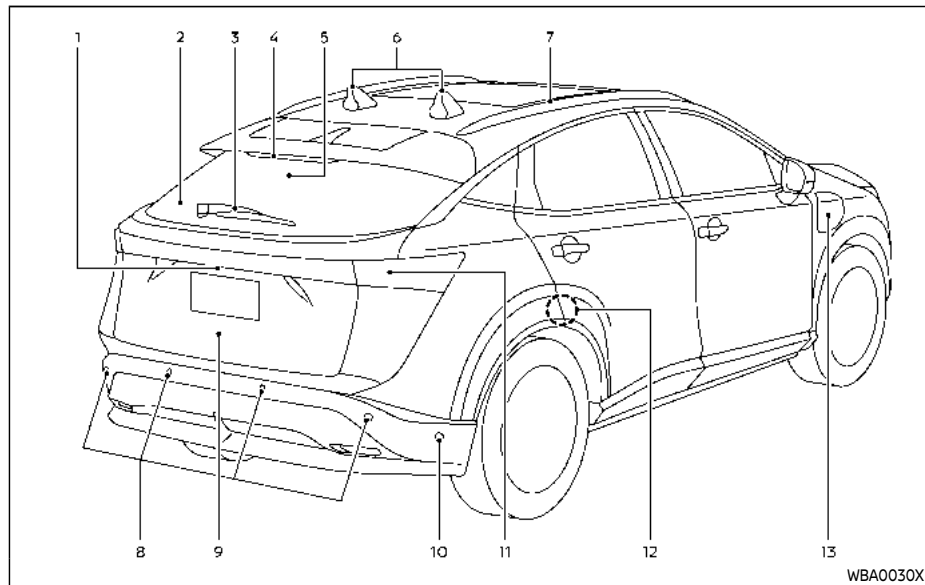

Example

- | | |
|--|--|
| 1. Rear view camera (P.4-3, P.4-11) | 5. Intelligent Rear View Mirror camera* (P.3-32) |
| 2. Rear window defroster (P.2-60) | 6. Antenna** (P.4-38) |
| 3. Rear window wiper and washer
— Switch operation (P.2-59)
— Window washer fluid (P.8-10) | 7. Roof rack* (P.2-90) |
| 4. High-mounted stop light (P.8-16) | 8. Sonar sensors (center and corner)
— Sonar system (P.5-160)
— ProPILOT Park* (P.5-165) |

- Rear Automatic Braking (RAB) (P.5-141)
- 9. Liftgate (P.3-21)
 - Intelligent Key system (P.3-6)
- 10. Sonar sensors (side)*
 - ProPILOT Park* (P.5-165)
 - Rear Automatic Braking (RAB) (P.5-141)
- 11. Rear combination lights (P.8-16)
- 12. Child safety rear door locks (P.3-6)
- 13. Charge port lid (P.3-27)

*: if so equipped

**:
For ProPILOT Assist 2.0 models, there are two antennas. (Left side is radio antenna, right side is GNSS antenna.)

For ProPILOT Assist with Navi-link models, there is one antenna.

PASSENGER COMPARTMENT

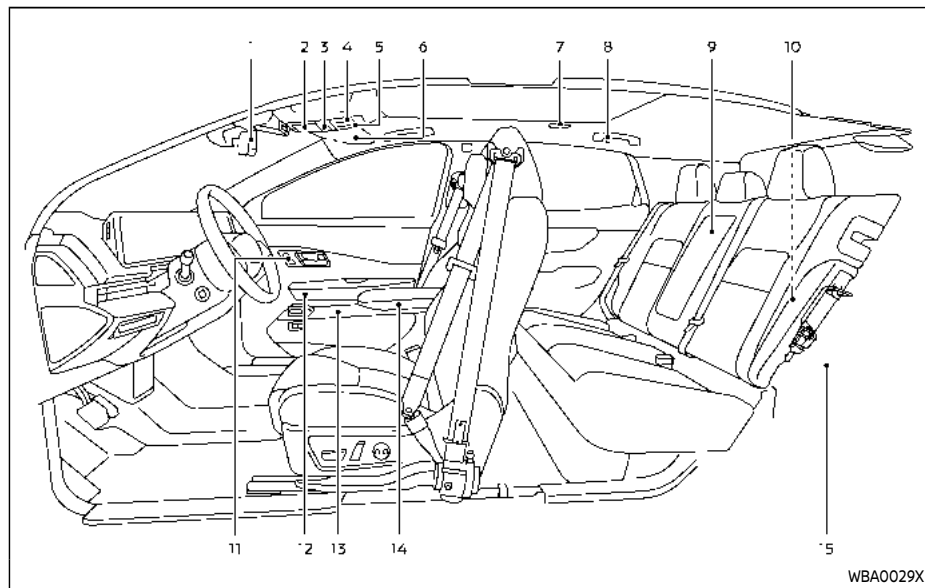

1. Inside mirror (P.3-31)
 - Intelligent Rear View Mirror* (P.3-32)
2. Sunglasses holder (P.2-87)
3. Map lights (P.2-98)
 - HomeLink® Universal Transceiver* (P.2-99)
 - Microphone**

4. Moonroof switch* (P.2-95)
5. Emergency Call (SOS) button (P.2-80)
6. Sun visors (P.3-30)
7. Rear personal lights (P.2-98)
8. Coat hooks (P.2-88)
9. Rear cup holders* (P.2-82)
10. Cargo light (P.2-99)

11. Memory seat switches* (driver's side and front passenger's side*) (P.3-41)
12. Front door armrest
 - Power window switch (P.2-91)
 - Outside mirror control switch (driver's side) (P.3-38)
 - Power door lock switches (P.3-5)
13. Front cup holders (P.2-82)
14. Center console
 - Armrest (P.1-9)
 - Power sliding armrest* (P.2-85)
 - Console box (P.2-85)
 - Wireless charger* (P.2-78)
 - Power outlet (P.2-77)
 - USB (Universal Serial Bus) charging connector (P.2-77)
 - Heated rear seat switches* (P.2-70)
15. Cargo area
 - Adjustable luggage floor (P.2-83)
 - Luggage hooks (P.2-90)
 - Cargo cover* (P.2-89)
 - Emergency tire puncture repair kit (P.6-4)
 - NISSAN EVSE (Electric Vehicle Supply Equipment)* (P.CH-5)

*: if so equipped

** : Refer to the separate NissanConnect® Owner's Manual.

COCKPIT

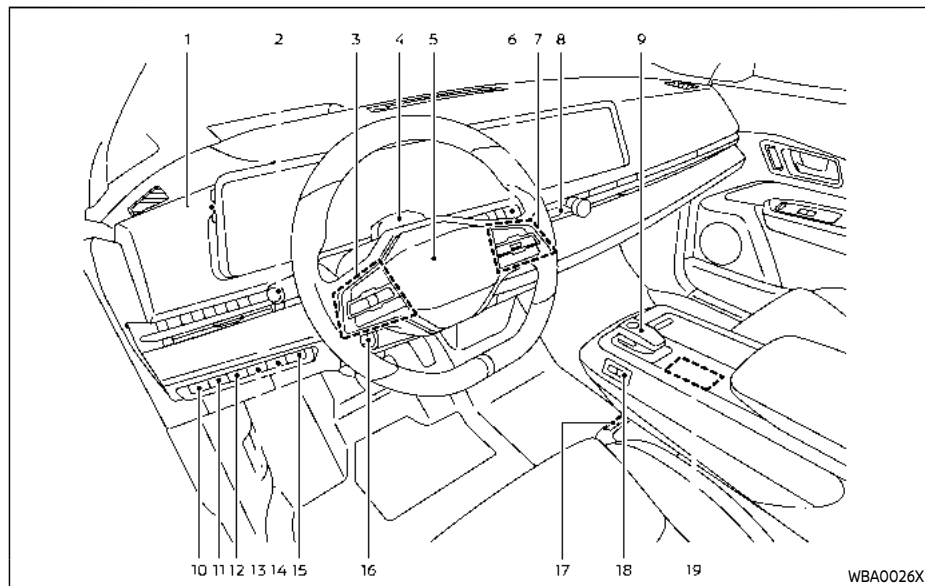

1. Instrument brightness control (P.2-10)
2. Headlight and turn signal switch (P.2-61)/ Fog light switch* (P.2-69)
3. Steering-wheel-mounted controls (left side)
 - Audio control**
 - Vehicle information display control (P.2-23)
4. Driver monitor camera
5. Steering wheel (P.3-29)
 - Horn (P.2-69)
6. Wiper and washer switch (P.2-56)
7. Steering-wheel-mounted controls (right side)
 - ProPILOT Assist switch (P.5-82, P.5-49,

P.5-63)

– Bluetooth® Hands-Free Phone System switches**

– Voice recognition switch**

– Siri® Eyes Free**

8. Hazard indicator flasher switch (P.6-2)
9. Shift lever/Park button (P.5-17)
10. Headlight aiming control switch (P.2-67)
11. Steering Assist switch (P.5-82)
12. Head Up Display (HUD) switch* (P.2-51)
13. Automatic brake hold switch (P.5-26)
14. Immediate charge switch (P.CH-37)
15. Power liftgate switch* (P.3-21)
16. Tilt and telescopic steering wheel control (P.3-29)
17. Power outlet (P.2-77)
 - USB (Universal Serial Bus) connection ports**
18. Power sliding armrest switch* (P.1-9)
19. Haptic switches
 - Drive Mode Selector (P.5-29)
 - e-Step switch (P.5-21)
 - ProPILOT Park switch* (P.5-165)
 - Flexible center storage switch* (P.2-86)

*: if so equipped

** : See the separate NissanConnect® Owner's Manual.

INSTRUMENT PANEL

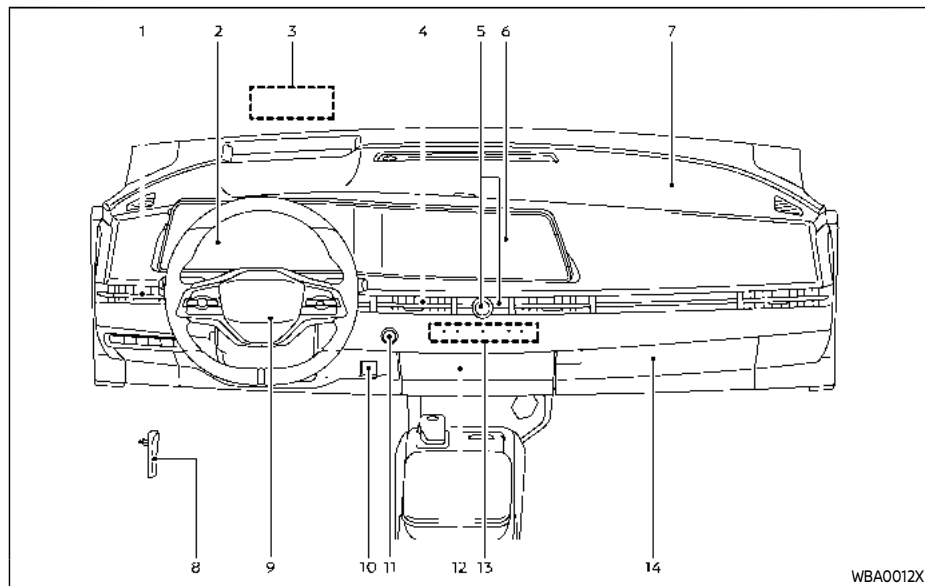

- | | |
|--|---|
| <ol style="list-style-type: none"> 1. Side ventilator (P.4-27) 2. Meters and gauges (P.2-5)/Vehicle information display (P.2-22)/Clock (P.2-51) 3. Head Up Display (HUD)* (P.2-51) 4. Center ventilator (P.4-27) 5. Audio switches** 6. Touch screen display | <ul style="list-style-type: none"> – Audio system** or navigation system** – RearView Monitor* (P.4-3) – Intelligent Around View® Monitor* (P.4-11) – Bluetooth® Hands-Free Phone System** – Heater and air conditioner control display (P.4-28) |
|--|---|

- Heated seat* (P.2-70)
 - Climate controlled seat* (P.2-73)
 - Heated steering wheel* (P.2-70)
7. Front passenger supplemental air bag (P.1-48)
 8. Hood release handle (P.3-20)
 9. Driver supplemental front-impact air bag (P.1-48)
 10. Parking brake switch (P.5-24)
 11. Push-button power switch (P.5-13)
 12. Flexible center storage (P.2-86)
 13. Heater and air conditioner control (P.4-28)
 - Rear window and outside mirror defroster switch (P.2-60)
 14. Glove box (P.2-84)
- *: if so equipped
- ** : See the separate NissanConnect® Owner's Manual.

WBA0012X

METERS AND GAUGES

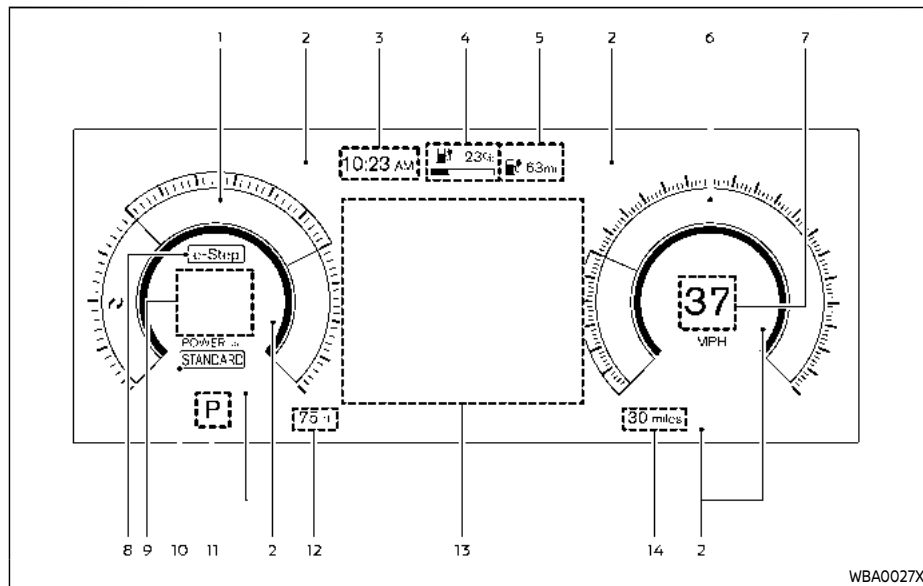

14. Odometer (P.2-7)

The view of the meter screen can be changed. (See "Changing the meter screen view" (P.2-6).)

1. Power meter (P.2-7)
2. Warning and indicator lights (P.2-11)
3. Clock (P.2-51)
4. Li-ion battery available charge gauge (P.2-8)
5. Driving range (P.2-9)
6. Speedometer (P.2-7)
7. Vehicle speed (P.2-7)
8. e-Step indicator (P.2-10, P.5-21)
9. Personal Display (P.2-24)
10. Drive Mode Selector indicator (P.5-29)
11. Shift position indicator (P.2-10)
12. Outside air temperature (P.2-51)
13. Vehicle information display (P.2-22)



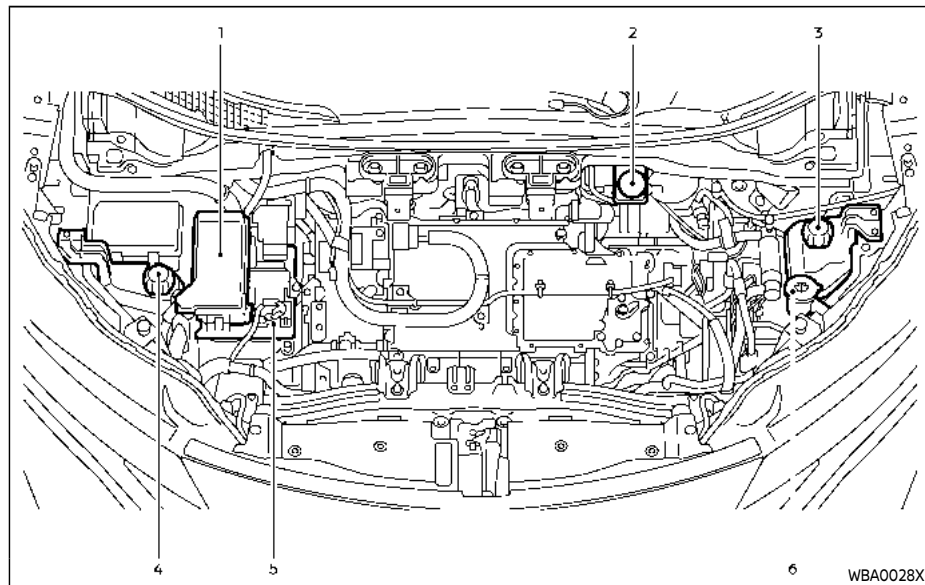







MOTOR COMPARTMENT

























Example

- | | |
|--|---|
| 1. Fuse/fusible link holders (P.8-15) | 4. Coolant reservoir (for Li-ion battery) (P.8-6) |
| 2. Brake fluid reservoir (P.8-7) | 5. 12-volt battery (P.8-11) |
| 3. Coolant reservoir (for electric powertrain) (P.8-6) | 6. Window washer fluid reservoir (P.8-10) |

WARNING AND INDICATOR LIGHTS

Red light	Name	Page
	12-volt battery charge warning light	2-12
	Brake warning light	2-13
		
	Electric shift control system warning light	2-13
	Electronic parking brake warning light	2-14
		
	Hands OFF warning light	2-14
	Master warning light	2-14
	Seat belt warning light	2-14
	Supplemental air bag warning light	2-15

Yellow light	Name	Page
	Anti-lock Braking System (ABS) warning light	2-15
		
	Approaching Vehicle Sound for Pedestrians (VSP) OFF indicator light	2-16
	Automatic Emergency Braking (AEB) system OFF warning light	2-16
	Brake system warning light (yellow)	2-16
	Electric power steering warning light	2-17
	EV system warning light	2-17
	Low battery charge warning light	2-17
	Low tire pressure warning light	2-17
	Master warning light	2-19
	Rear Automatic Braking (RAB) system OFF warning light	2-19
	Slip indicator light	2-19
	Vehicle Dynamic Control (VDC) off indicator light	2-19

Other light	Name	Page
	Automatic brake hold indicator light (white)	2-20
	Automatic brake hold indicator light (green)	2-20
	Exterior light indicator	2-20
	Front fog light indicator light (if so equipped)	2-20
	High beam assist indicator light	2-20
	High beam indicator light	2-20
	Plug in indicator light	2-20
	Power limitation indicator light	2-20
	READY to drive indicator light	2-21
	Turn signal/hazard indicator lights	2-21

Overview

The EV (Electric Vehicle) system	EV-2	Operating the climate control system before driving	EV-11
Li-ion battery	EV-2	Starting your vehicle	EV-12
Driving with a discharged Li-ion battery	EV-3	Driving the vehicle	EV-13
Charging the 12-volt battery	EV-4	Charging after driving	EV-15
Li-ion battery temperature control system	EV-5	Efficient use of your vehicle	EV-16
High voltage precautions	EV-6	Range	EV-16
High-voltage components	EV-6	Improve driving range	EV-16
Road accident precautions	EV-8	Li-ion battery life	EV-17
Emergency shut-off system	EV-8	Li-ion battery maintenance	EV-17
EV (Electric Vehicle) characteristics	EV-9	EV (Electric Vehicle) unique information	EV-18
Noise and vibration	EV-10	Meters and indicators	EV-18
Life with an EV (Electric Vehicle) (scene guide)	EV-10	Approaching Vehicle Sound for Pedestrians (VSP) system	EV-20
Charging the Li-ion battery	EV-10	EV functions	EV-21
Checking Li-ion battery charging status	EV-10		

THE EV (Electric Vehicle) SYSTEM

The ARIYA is an electric vehicle. Some of the vehicle's systems operate differently and have different operating characteristics than vehicles equipped with an internal combustion engine. It is important to carefully review the entire Owner's Manual for this reason. The main difference is the ARIYA is powered by electricity. The ARIYA does not require and it is not capable of using gasoline like a vehicle powered by a traditional internal combustion engine. The ARIYA uses electricity stored in the lithium ion (Li-ion) battery. The vehicle Li-ion battery must be charged with electricity before the vehicle can be driven. As the vehicle operates, the Li-ion battery gradually discharges. If the Li-ion battery becomes completely discharged, the vehicle will not operate until it is re-charged.

This vehicle uses two types of batteries. One is the 12-volt battery that is the same as the battery in vehicles powered by gasoline engine, the other is the Li-ion battery (high voltage).

The 12-volt battery provides power to the vehicle systems and features such as the audio system, supplemental restraint systems, headlights and windshield wipers.

The Li-ion battery provides power to the electric motor (traction motor) that moves the vehicle.

The Li-ion battery also charges the 12-volt battery.

The vehicle must be plugged in for the Li-ion battery to be charged. Additionally, the vehicle system can extend the driving range by converting driving force into electricity that is stored in the Li-ion battery while the vehicle is decelerating or being driven downhill. This is called regenerative brake. This vehicle is considered to be an environmentally friendly vehicle because it does not emit exhaust gases, such as carbon dioxide and nitrogen oxide.

LI-ION BATTERY



WARNING

Your vehicle contains a sealed Li-ion high voltage battery. If the Li-ion battery is disposed of improperly, there is a risk of severe burns and electrical shock that may result in serious injury or death and there is also a risk of environmental damage.



CAUTION

To prevent damage to the Li-ion battery:

- **Do not expose the vehicle to extreme ambient temperatures for extended periods.**
- **Do not store the vehicle in temperatures below -13°F (-25°C) for over seven days.**
- **Do not leave your vehicle for over 14 days where the Li-ion battery available charge gauge reaches a zero or near zero.**
- **Do not use the Li-ion battery for any other purpose.**

- Do not spill water onto the Li-ion battery or load large amounts of water in open containers (aquariums or buckets) into the vehicle. If the water spills onto the Li-ion battery, it may cause a short circuit and damage the Li-ion battery.

NOTE:

- If the outside temperature is -13°F (-25°C) or less, the Li-ion battery may freeze and it cannot be charged or provide power to drive the vehicle. Move the vehicle to a warm location.
- The capacity of the Li-ion battery in your vehicle to hold a charge will, like all such batteries, decrease with time and usage. As the battery ages and capacity decreases, this will result in a decrease from the vehicle's initial driving range. This is normal, expected, and not indicative of any defect in your Li-ion battery.
- The Li-ion battery has limited service life, and when its charging capacity falls below a specific level, the EV system warning light will illuminate. Owners should bring their vehicle in for inspection and possible battery replacement.

- It is recommended that you visit a **NISSAN** certified **ARIYA** dealer for information about recycling or disposal of the Li-ion battery. Do not attempt to recycle or dispose of the Li-ion battery yourself.

DRIVING WITH A DISCHARGED LI-ION BATTERY

When a destination is set in the navigation system that exceeds the available vehicle range, the navigation system automatically searches the location of nearby charging stations. When the nearby charging station locations are displayed, charge the Li-ion battery as soon as possible.

Warning lights illuminate on the instrument panel and messages are displayed on the vehicle information display to inform you that the Li-ion battery charge is low.

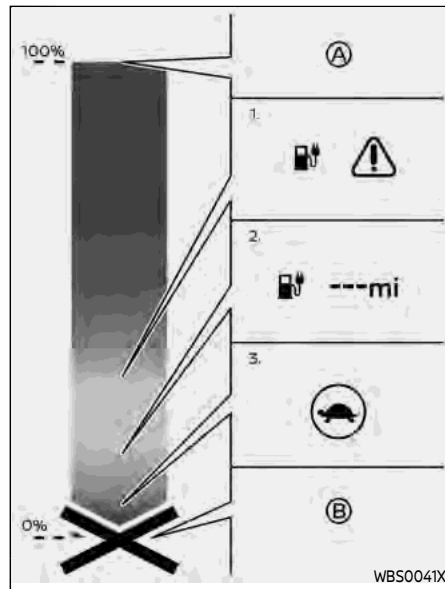

The vehicle's range is very limited when these warning lights illuminate and messages are displayed. Follow the instructions on the vehicle information display and immediately charge the vehicle at the nearest charging station.

There are three levels of information that will be displayed as the Li-ion battery becomes discharged:



- Ⓐ Full charge
- 1. Low Li-ion battery warning
- 2. "---" indication
- 3. Traction motor output limited
- Ⓑ Battery discharged
- 1. The following warning lights illuminate on the meter and messages are

displayed on the vehicle information display at the same time to indicate low Li-ion battery charge. Charge the Li-ion battery as soon as possible.

- The low battery charge warning light (yellow) 
- The master warning light  (yellow)
- "Battery too Low Please charge now" warning message is displayed on the vehicle information display. See "Vehicle information display warnings and indicators" (P.2-34).

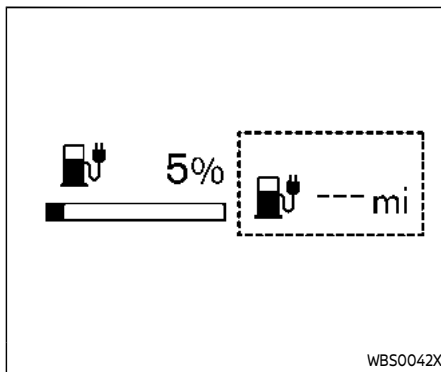

2. If the vehicle is driven and the Li-ion battery continues to discharge, the driving range changes to "--".
3. When the power limitation indicator light  illuminates, traction motor output is limited resulting in reduced vehicle speed. Stop the vehicle in a safe location before the Li-ion battery becomes completely discharged and there is no power available to drive the vehicle. See "If the Li-ion battery becomes completely discharged" (P.6-18).

CHARGING THE 12-VOLT BATTERY

The 12-volt battery is charged automatically using electricity stored in the Li-ion battery.

When the 12-volt battery is being charged, the charging status indicator light on the instrument panel flashes. (except when charging the Li-ion battery or the power switch is in the READY to drive position.) See "Charging status indicator light" (P. CH-38).

While vehicle is in use

The Li-ion battery charges the 12-volt battery as necessary when the power switch is in the READY to drive position or ON position.

The 12-volt battery is not charged in the following conditions.

- When the power switch is in Auto ACC position.
- When the power switch is in ON position and shift position is in the N (Neutral) position.

While the vehicle is not in use

When the EV (Electric Vehicle) system is off for an extended time, the 12-volt battery may be automatically charged for a short period of time on a regular basis.

LI-ION BATTERY TEMPERATURE CONTROL SYSTEM

This system helps to prevent the Li-ion battery temperature from becoming too high or low.

Li-ion battery cooler

- When the Li-ion battery temperature becomes higher, it can cause an acceleration decline and longer charging time by the quick charger.
- The Li-ion battery temperature tends to rise in the case of continued driving on a freeway, repeated use of quick charger, and combination of both operations.
- The Li-ion battery cooler will automatically turn on when the Li-ion battery temperature rises during driving or quick charging. It will keep the Li-ion battery temperature to a level that does not activate power limitation or charging inhibition. This function is useful when driving a long distance with repeated use of quick charger.

- When the Li-ion battery cooler operates, more electric power will be consumed than in normal driving condition, which could result in a decreased energy economy and driving range. Avoid unnecessary acceleration and deceleration and drive at a moderate speed.

Li-ion battery warmer

- When the Li-ion battery temperature becomes lower, it can cause longer charging time by the quick charger.
- The Li-ion battery temperature tends to fall, for example, when parking the vehicle for a long period of time while the outside temperature is below 32 °F (0 °C). The Li-ion battery temperature is lowered to the outside temperature.
- The Li-ion battery warmer will automatically turn on when the Li-ion battery temperature is cold during quick charging. It will also turn on while driving, if the function is enabled on the touch screen display. It will raise the Li-ion battery temperature to avoid extending charging time when using the quick charger.
- When the Li-ion battery warmer operates while quick charging, it uses electrical power from the quick charger. However, the Li-ion battery warmer can increase an amount of

charge in 30 minutes by approximately 1.3 times to twofold*, in the case that the Li-ion battery temperature is below 32 °F (0 °C).

*: It varies depending on the temperature and/or remaining capacity of the Li-ion battery at the start of charging.

- When the quick charge is performed immediately after the Li-ion battery warmer operated while driving, an amount of charge in 30 minutes is increased by 1.2 to 1.7 times*, in comparison with the case that the Li-ion battery warmer only operates during quick charging.

*: It varies depending on the temperature and/or remaining capacity of the Li-ion battery at the start of charging.

- To allow the Li-ion battery warmer to operate while driving, enable the function on the touch screen display in the following steps:
 - 1) Place the power switch in the READY to drive position. (The setting cannot be performed while driving.)
 - 2) Touch the "🏠" key on the Launch bar.
 - 3) Touch the "⚙️" key and then touch "EV" key.

- 4) Touch the "Battery Heater" key and touch the "ON" key to enable the function.

NOTE:

- When the Li-ion battery warmer operates while driving, more electric power will be consumed than in normal driving condition, which could result in a decreased energy economy and driving range. Take account of remaining Li-ion battery charge and estimated driving range while driving.
- If the outside temperature is low and a low temperature alert [] is displayed in the vehicle information display, it is recommended to turn ON "Battery Heater" 30 minutes to 1 hour before arriving at a quick charging station.
- The "Battery Heater" setting will be turned OFF when the quick charging is completed or the power switch is placed in the OFF position.

HIGH VOLTAGE PRECAUTIONS

HIGH-VOLTAGE COMPONENTS



WARNING

- The EV (Electric Vehicle) system uses high voltage up to approximately DC 400 volt. The system can be hot during and after starting and when the vehicle is shut off. Be careful of both the high voltage and the high temperature. Follow the warning labels that are attached to the vehicle.
- Never touch, disassemble, remove or replace high-voltage parts and cables as well as their connectors because they can cause severe burns or electric shock that may result in serious injury or death. High-voltage cables are colored orange. The vehicle high voltage system has no user serviceable parts. It is recommended that you take your vehicle to a NISSAN certified AR-IYA dealer for any necessary maintenance.

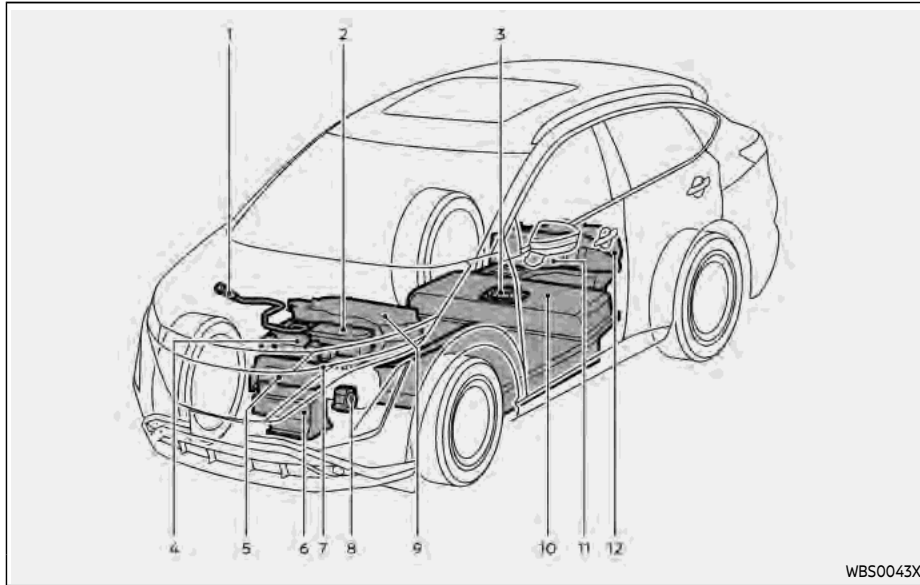

- 8. Air conditioner compressor
- 9. PTC heater
- 10. Li-ion battery
- 11. Rear inverter (AWD models)
- 12. Rear traction motor (AWD models)

High-voltage components

- | | |
|---|--|
| 1. High-voltage wire harnesses (colored orange) | 5. Inverter (2WD models)/Front inverter (AWD models) |
| 2. High voltage junction box | 6. Traction motor (2WD models)/Front traction motor (AWD models) |
| 3. Service plug | 7. DC/DC converter |
| 4. On Board Charger (OBC) | |

ROAD ACCIDENT PRECAUTIONS



WARNING

In case of a collision:

- If your vehicle is drivable, pull your vehicle off the road, push the park button on the shift lever, apply the parking brake and turn the EV (Electric Vehicle) system off.
- Check your vehicle to see if there are exposed high-voltage parts or cables. For their locations, see “High-voltage components” (P. EV-6). To avoid personal injury, never touch high-voltage wiring, connectors, and other high-voltage parts, such as the On Board Charger (OBC), inverter unit and Li-ion battery. An electric shock may occur if exposed electric wires are visible when viewed from inside or outside of your vehicle. Therefore, never touch exposed electric wires.
- If the vehicle receives a strong impact to the floor while driving, stop the vehicle in a safe location and check the floor.
- Leaks or damage to the Li-ion battery may result in a fire. If

you discover them, contact emergency services immediately. Since the fluid leak may include electrolyte from the Li-ion battery, never touch the fluid leak inside or outside the vehicle. If the fluid contacts your skin or eyes, wash it off immediately with a large amount of water and receive immediate medical attention to help avoid serious injury.

- If a fire occurs in the EV (Electric Vehicle), leave the vehicle as soon as possible. Only use a type ABC, BC or C fire extinguisher that is meant for use on electrical fires. Using a small amount of water or the incorrect fire extinguisher can result in serious injury or death from electrical shock.
- If your vehicle needs to be towed, do it with the front wheels raised (for 2WD models) or all wheels raised (for AWD models). If the front wheels (for 2WD models) and/or rear wheels (for AWD models) are on the ground when towing, the traction motor may be damaged.

- If you are not able to safely assess the vehicle due to vehicle damage, do not touch the vehicle. Leave the vehicle and contact emergency services. Advise 1st responders that this is an electric vehicle.
- In the event of an accident that requires body repair and painting, the Li-ion battery pack and high voltage parts such as the inverter, including the wire harness, should be removed prior to painting. It is recommended that you visit a NISSAN certified ARIYA dealer for this service. Li-ion battery packs exposed to heat in the paint booth will experience capacity loss. Damaged Li-ion battery packs may also pose safety risks to untrained mechanics and repair personnel.

EMERGENCY SHUT-OFF SYSTEM

The emergency shut-off system is activated and the high-voltage system automatically turns off in the following conditions:

- Front and side collisions in which the air bags are deployed.
- Certain rear collisions.

EV (Electric Vehicle) CHARACTERISTICS

- Certain EV (Electric Vehicle) system malfunctions

For the above collisions and certain other EV (Electric Vehicle) system malfunctions, the READY to drive indicator light will turn off. See "Warning lights, indicator lights and audible reminders" (P.2-11).

The emergency shut-off activates for the above collisions to minimize risk of an event that could cause injury or an accident. If the emergency shut-off system activates, the EV system may not be switched to READY to drive position, it is recommended that you visit a NISSAN certified ARIYA dealer. Even if the power switch is switched to READY to drive position, the system may shut-off suddenly. Therefore, drive cautiously to the nearest certified repair facility; it is recommended that you visit a NISSAN certified ARIYA dealer for service.



WARNING

- Pay special attention to pedestrians. Because there is no engine noise, pedestrians may not know the vehicle is approaching, moving or about to move, and may step into the path of vehicle travel.
- When leaving the vehicle, be sure to turn off the EV (Electric Vehicle) system.
- Be sure to push the park button on the shift lever and apply the parking brake when parking because the vehicle can move when the READY to drive indicator light is ON. When the READY to drive indicator light is ON, do not leave your vehicle in a shift position other than the P (Park) position.
- Keep the brake pedal depressed until you are ready to drive. When the vehicle is in the D (Drive), B or R (Reverse) position, if you release the brake pedal and do not depress accelerator, the vehicle will creep and may start abruptly. This may cause serious injury or death.

NOTE:

- The vehicle cannot run with a discharged Li-ion battery. Repeated acceleration consumes more power from the Li-ion battery than driving at a steady speed.
- This vehicle is equipped with a regenerative brake system. The primary purpose of regenerative brake system is to provide some power to recharge the Li-ion battery and extend driving range. A secondary benefit is "engine braking" that operates based on Li-ion battery conditions.
- In the D (Drive) position, when the accelerator pedal is released, the regenerative brake system provides some deceleration.
- When you place the shift lever in the B position and take your foot off the accelerator pedal, more regenerative brake is applied than in the D (Drive) position.
- Less deceleration is provided by the regenerative brake system when the Li-ion battery is fully charged. Regenerative brake is automatically reduced when the Li-ion battery is fully charged to prevent the Li-ion battery from becoming overcharged. Regenerating brake is also automatically reduced when the

battery temperature is high/low to prevent Li-ion battery damage.

- **The brake pedal should be used to slow or stop the vehicle depending on traffic or road conditions. The vehicle brakes are not affected by regenerative brake system operation.**
- **The regenerative brake system may not function properly depending on tire conditions.**

NOISE AND VIBRATION

You might experience the following noise or vibration as a normal characteristic of this vehicle.

- Traction motor noise from motor compartment
- Water pump and radiator fan noise while charging
- Compressor and radiator fan noise when the Climate Ctrl. Timer or the Remote Climate Ctrl. (if so equipped) is used
- Relay operation noise and vibration at start-up and shut-down of the EV (Electric Vehicle) system (power switch placed in the ON and OFF position)
- Approaching Vehicle Sound for Pedestrians (VSP)

LIFE WITH AN EV (Electric Vehicle) (scene guide)

This section provides a brief explanation of the most important EV functions. Refer to the specific sections of this manual for detailed explanations of the vehicle features and operation.

CHARGING THE LI-ION BATTERY



WARNING

The EV (Electric Vehicle) system uses a high voltage current. Failure to follow the proper handling instructions may cause serious injury or death. Be sure to read the “CH. Charging” section and follow the procedures and guidelines described.

CHECKING LI-ION BATTERY CHARGING STATUS

The Li-ion battery charge status can be checked on the NissanConnect® Services app (if so equipped).

If the Li-ion battery is not sufficiently charged, you can start charging the Li-ion battery via the remote charge function. For additional information, see “Charging related remote function” (P. CH-37).

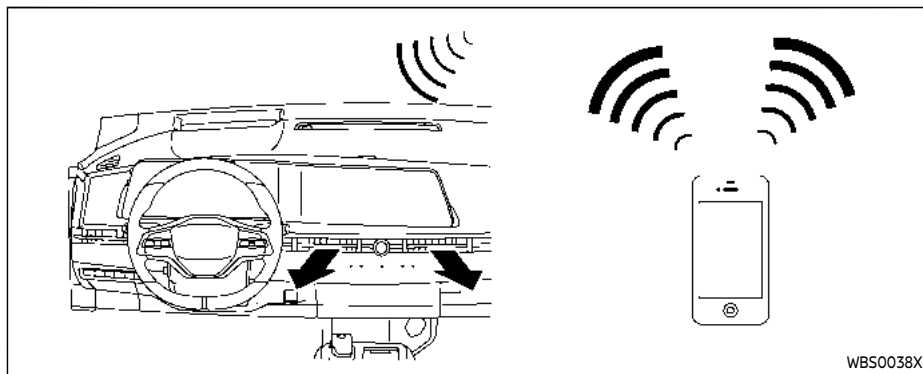

OPERATING THE CLIMATE CONTROL SYSTEM BEFORE DRIVING

The vehicle's heating and air conditioning system can be turned on via remote control with an internet enabled smart phone using NissanConnect® Services app (if so equipped).

This allows the interior of the vehicle to be heated or cooled while the vehicle is charging. This reduces the load on the Li-ion battery while the vehicle is being driven and can help increase the vehicle driving range. For additional information, please visit <http://www.nissanusa.com/connect/>.

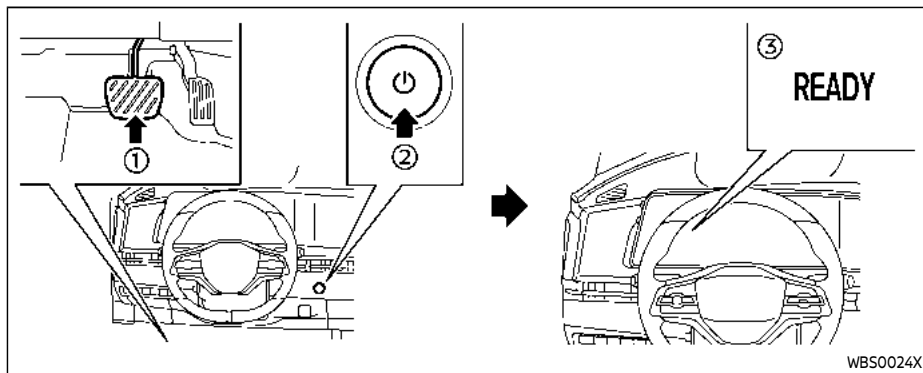

STARTING YOUR VEHICLE

1. Firmly depress the brake pedal.
2. Push the power switch.
3. Check that the READY to drive indicator light illuminates. See "READY to drive indicator light" (P.2-21).
4. Check the Li-ion battery level and the estimated driving range shown on the vehicle information display. See "Li-ion battery available charge gauge" (P.2-8) and "Driving range" (P.2-9).

NOTE:

- **Before driving, compare the driving distance to the destination displayed on the navigation system**

- **screen with the estimated driving range shown on the meter. Determine if it will be necessary to charge the Li-ion battery before or while driving to your planned destination.**
- **If it is necessary to charge the Li-ion battery, use the navigation system to search for available charging stations on your planned driving route.**

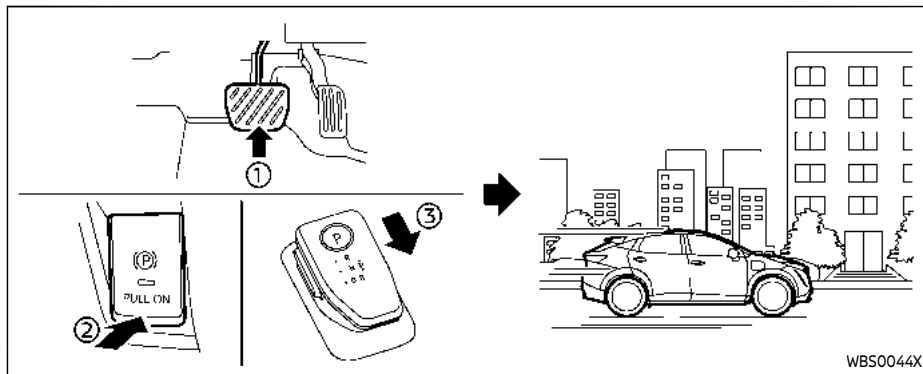

DRIVING THE VEHICLE

1. Depress the brake pedal.
2. Release the parking brake.
3. Move the shift lever into the D (Drive) position. When released, the shift lever returns to its original center position.
4. Confirm that the vehicle is in the D (Drive) position. The shift indicator on the shift lever illuminates and "D" is displayed on the vehicle information display.
5. Release the brake pedal.
6. Depress the accelerator pedal and start driving.

There are the following gear positions for

driving the vehicle forward:

- Use the D (Drive) position for optimum driving performance.
- Use the B position for downhill driving. When the B position is used, more regenerative brake is applied when the accelerator pedal is released in comparison to the D (Drive) position.

NOTE:

The regenerative brake converts the vehicle's forward motion to electric power to help slow the vehicle.

See "Driving the vehicle" (P.5-17).

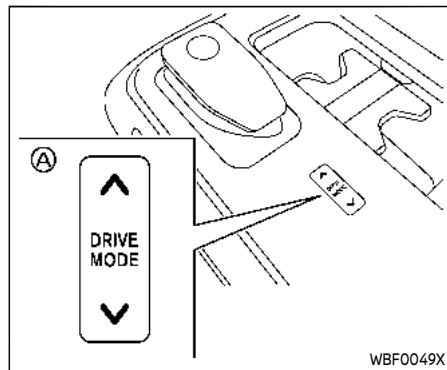

Use the Drive Mode Selector (A) located on the center console to select the ECO mode. Use the ECO mode for maximum driving range and for city driving. The ECO mode helps reduce power consumption by reducing acceleration when compared to the same accelerator pedal position in the STANDARD mode. See "ECO mode" (P.5-30).

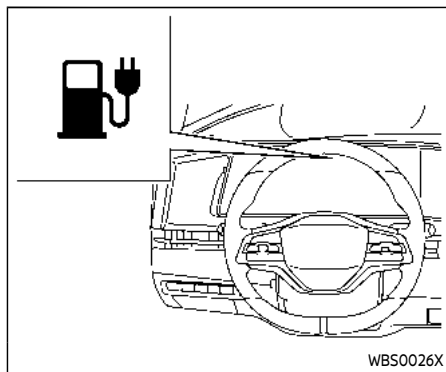

If the low battery charge warning light  (yellow) illuminates, the Li-ion battery charge is too low for travel. See "Low battery charge warning light" (P.2-17). Charge the Li-ion battery as soon as possible.

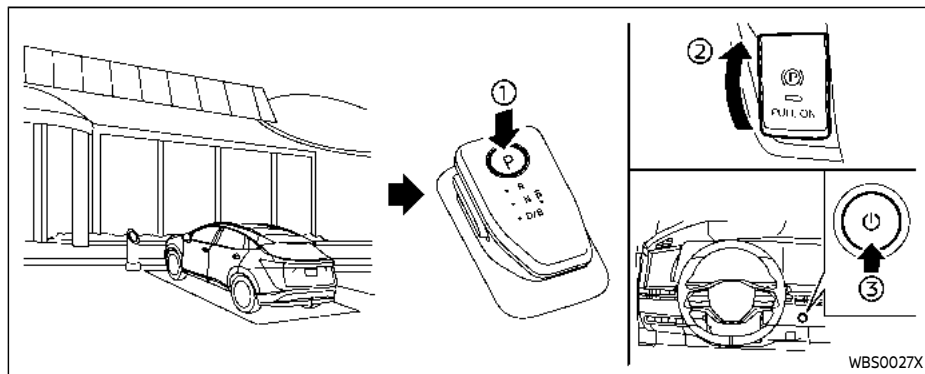

Parking the vehicle

1. When stopping the vehicle, push the park button on the shift lever while depressing the brake pedal. Confirm that the vehicle is in the P (Park) position by checking the shift indicator on the shift lever or on the vehicle information display.
2. Apply the parking brake.
3. Push the power switch to the OFF position.
4. If a parking lot is equipped with charging facilities, charge the Li-ion battery as necessary. See "Types of charge and how to charge the Li-ion battery" (P.CH-5).

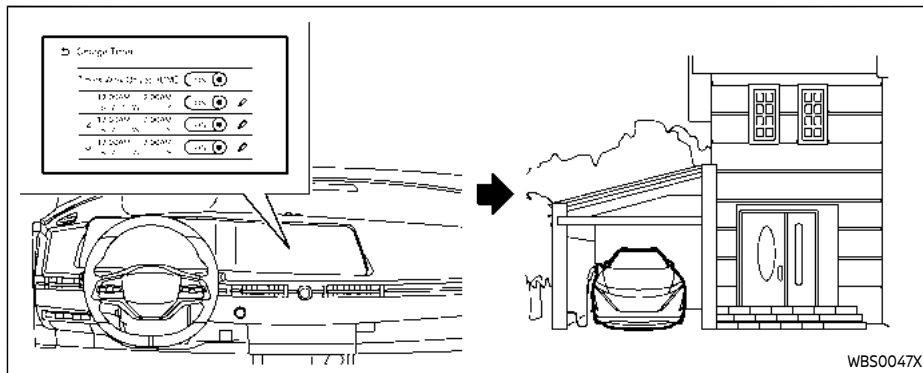

CHARGING AFTER DRIVING

Charging the Li-ion battery

When you return home, connect the vehicle to the charging station installed at your home using the normal charge connector.

Charge the vehicle or set the charging timer function on the touch screen display to have the vehicle charge at a specific time. See "Charging timer" (P.CH-35).

1. When the power switch is turned off, the settings of the charging timer, the Climate Ctrl. Timer and charge connector lock functions are displayed on

the vehicle information display. See "Vehicle information display" (P.2-22).

2. Open the charge port lid and charge port cap. See "Charge port lid" (P.3-27).
3. Connect the charge connector to the vehicle.
4. When a charging timer is turned on, charging starts at the set time. When a charging timer is not turned on, charging starts immediately.

NOTE:

- **Charging can be started remotely, even if the charging timer is set up.**
- **When you have forgotten to connect the charge connector at home, there**

is a function that can notify you via a text message capable cellular phone, internet enabled smart phone using NissanConnect® Services app (if so equipped). For additional information, see "Charging related remote function" (P.CH-37).

- **NISSAN recommends that you connect the normal charge cable to your vehicle when getting out of the vehicle, even if it is not going to be used. By doing this, you can get the most out of the Climate Ctrl. Timer functions the next time you use the vehicle.**

EFFICIENT USE OF YOUR VEHICLE

RANGE

The distance you can drive the vehicle (driving range) varies considerably depending upon available charge, weather, temperature, usage, battery age, topography, and driving style.

Refer to the Monroney label (window sticker) for the official EPA range. Your actual range will vary and could be significantly less, either initially or as the battery ages and with use over time. For additional information, see "Improve driving range" (P.EV-16) for information on the factors that affect vehicle range and how to use the vehicle to maximize vehicle range.

IMPROVE DRIVING RANGE

The available driving range depends on a number of factors.

Actual driving range will vary depending upon:

- Speed,
- Vehicle load,
- Electrical load from vehicle accessories,
- Traffic and road conditions,
- Distance driven without stopping,
- Usage,
- Driving style,

- Battery age,
- Weather or temperature,
- Topography,
- Charging habits.

NISSAN recommends the following driving habits to help maximize driving range:

Before driving:

- Follow recommended scheduled maintenance.
- Keep tires inflated to the correct pressure.
- Keep wheels correctly aligned.
- Pre-heat or pre-cool the interior cabin while the vehicle is charging.
- Remove unnecessary cargo from the vehicle.

While driving:

- Drive in ECO mode
 - The ECO mode helps reduce power consumption by reducing acceleration when compared to the same accelerator pedal position in the STANDARD mode.
- Drive at a constant speed. Maintain cruising speeds with a constant accelerator pedal position or by using the cruise control system when appropriate.

- Accelerate slowly and smoothly. Gently depress and release the accelerator pedal for acceleration and deceleration.
- Drive at moderate speeds on the highway.
- Avoid frequent stopping and braking. Maintain a safe distance behind other vehicles.
- Turn off the climate control system when it is not needed.
- Select a moderate temperature setting for heating or cooling to help reduce power consumption.
- Use only the fan to help reduce power consumption.
- In cold weather, use the heated seats and the heated steering wheel (if so equipped) as a substitute for climate control system to help reduce power consumption.
- Use the climate control system to control interior temperature and close windows to reduce drag when cruising at highway speed.
- Release the accelerator pedal to slow down and do not apply the brakes when traffic and road conditions allow.
 - This vehicle is equipped with a regenerative brake system. The primary purpose of the regenera-

tive brake system is to provide some power to recharge the Li-ion battery and extend driving range. A secondary benefit is the “engine braking” effect that operates based on Li-ion battery conditions. In the D (Drive) or B position, when the accelerator is released, the regenerative brake system provides some deceleration and some power to the Li-ion battery.

- The vehicle driving range may be substantially reduced in extremely cold conditions (for example -4 °F (-20 °C)).
- Using the climate control system to heat the cabin when the outside temperature is below 32°F (0°C) uses more electricity and affects the vehicle driving range more than when using the heater when the temperature is above 32°F (0°C).

LI-ION BATTERY LIFE

The Li-ion battery's ability to hold a charge, like all batteries, decreases with battery age and usage which results in decreased driving range when compared to the driving range when the vehicle was new. This is normal and expected, and does not indicate a malfunction of the vehicle or Li-ion battery.

The Li-ion battery's ability to hold a

charge can be affected by how you drive the vehicle, store the vehicle, how you charge the Li-ion battery and Li-ion battery temperature during vehicle operation and charging.

To maximize the battery's useful life, use the following driving and charging habits where possible.

- Avoid exposing a vehicle to extreme ambient temperatures for extended periods.
- Avoid storing a vehicle in temperatures below -13°F (-25°C) for over 7 days.
- Avoid leaving your vehicle for over 14 days where the Li-ion battery available charge gauge reaches a zero or near zero (state of charge).
- Allow the vehicle and Li-ion battery to cool down after use before charging.
- Park/store your vehicle in cool locations out of direct sunlight and away from heat sources.
- Avoid sustained high battery temperatures (caused, for example, by exposure to very high ambient temperatures or extending highway driving with multiple quick charges).
- Use the normal charging or trickle charging method to charge the Li-ion battery and minimize the use of

public Fast Charge or Quick Charger.

- Drive moderately.
- Use the ECO mode.
- Do not operate the charging timer repeatedly while the charge connector is connected to the vehicle after the Li-ion battery charging is completed. Doing so may discharge the 12-volt battery.
- If the vehicle will not be used for an extended period of time, charge the Li-ion battery once every 3 months.
- The power of the Li-ion battery can be checked on the Li-ion battery available charge gauge. See “Li-ion battery available charge gauge” (P.2-8).

LI-ION BATTERY MAINTENANCE

In addition to the regular maintenance recommended by NISSAN, the ARIYA requires some special Li-ion battery inspections.

- For additional information, refer to the NISSAN Warranty Information Booklet for significant limitations, exclusions and possible voiding of your warranty resulting from failure to have these necessary inspections, repairs and/or adjustments performed.
- For a detailed explanation of the Li-ion battery inspection and intervals, see “EV maintenance schedules (AM67

EV (Electric Vehicle) UNIQUE INFORMATION

electric motor). (See "Maintenance schedules" (P.9-6).)

METERS AND INDICATORS

Various meters, gauges and indicators related to the EV (Electric Vehicle) functions are displayed in the vehicle information display.

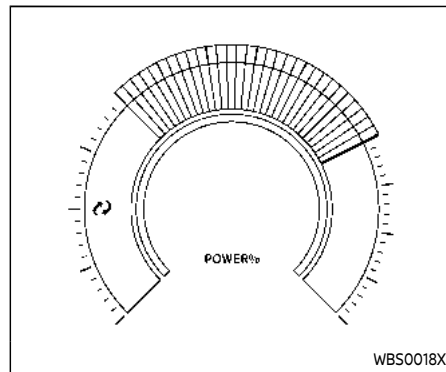

Vehicle information display

Power meter:

This meter displays the actual traction motor power consumption and the regenerative brake power provided to the Li-ion battery.

For additional information, see "Power meter" (P.2-7).

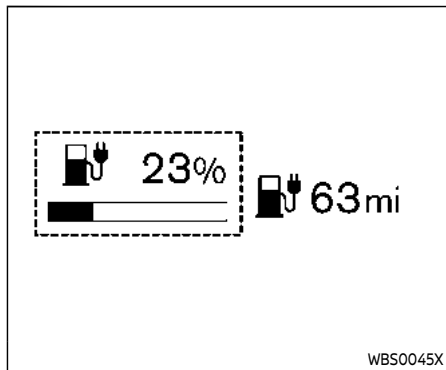

Driving range:

This indicator displays the estimated driving range (calculated based on a program that accounts for current driving style and operational conditions) that can be driven before recharging is necessary.

For additional information, see "Driving range" (P.2-9).

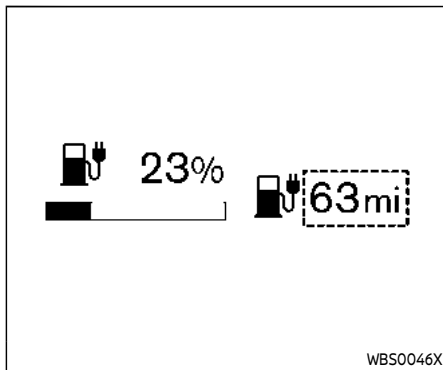

Li-ion battery available charge gauge:

This indicator displays the available Li-ion battery power remaining to drive the vehicle.

For additional information, see "Li-ion battery available charge gauge" (P.2-8).

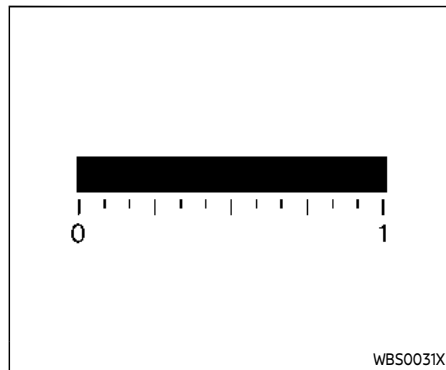

Li-ion battery capacity level gauge:

This gauge displays the available capacity of the Li-ion battery remaining to store power.

To check this gauge, select it in the trip computer menu. For additional information, see "9. Battery Capacity" (P.2-47).

Other information:

The other EV unique information is displayed on the trip computer as well. For additional information, see "Trip computer" (P.2-45).

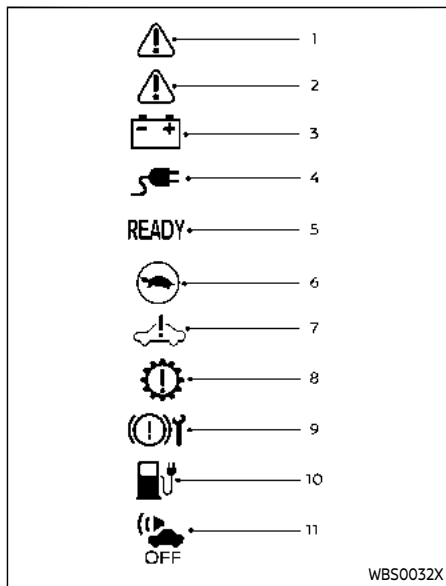

2. Master warning light (yellow)
3. 12-volt battery charge warning light
4. Plug in indicator light
5. READY to drive indicator light
6. Power limitation indicator light
7. EV system warning light
8. Electric shift control system warning light
9. Brake system warning light (yellow)
10. Low battery charge warning light
11. Approaching Vehicle Sound for Pedestrians (VSP) system off indicator light

For additional information, see "Warning lights, indicator lights and audible reminders" (P.2-11).

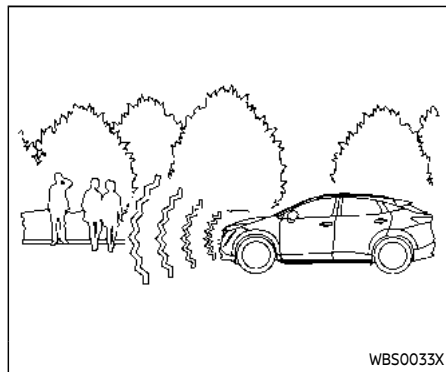

APPROACHING VEHICLE SOUND FOR PEDESTRIANS (VSP) SYSTEM

The Approaching Vehicle Sound for Pedestrians (VSP) system is a function that uses sound to alert pedestrians of the presence of the vehicle when it is being driven at a low speed.

When the vehicle starts to move, it produces a sound.

The sound stops when the vehicle speed is more than approximately 25 MPH (40 km/h) while accelerating.

The sound starts when the vehicle speed is less than approximately 22 MPH (35 km/h) while decelerating.

Warning and indicator lights

The EV system uses the following EV specific warning and indicator lights, located in the meter panel.

1. Master warning light (red)



WARNING

- If the sound from the VSP system is not heard while driving, stop the vehicle in a safe and quiet location. Open a window and then place the vehicle in the R (Reverse) position with the brake pedal firmly depressed. Check that the operating sound can be heard from the front of the vehicle.
- If the sound cannot be heard when the VSP system is operational, or the VSP OFF indicator light is illuminated, it is recommended that you visit a NISSAN certified ARIYA dealer immediately for inspection.

EV FUNCTIONS

EV (Electric Vehicle) screen

The EV (Electric Vehicle) screen allows you to use the following features:

- Energy Usage
- Driving Range
- Charging Stations
- Charge Timer
- Climate Ctrl. Timer

How to show the screen:

Home screen → all app → second page → EV

Refer to the "NissanConnect® Manual".

EV unique function settings

The EV unique function settings allow you to use the following items:

Available setting items may vary depending on models, specifications, software versions and conditions.

- Battery & Power Alerts
- Charging Messages
- Map icons for charging stations
- Filter for Map Icons
- Autosave New Charging Stations
- Charging Availability
- Favorite Charging Locations

- Battery Heater
Home screen → Settings → EV
Refer to the "NissanConnect® Manual".

MEMO

CH Charging

Precautions on charging	CH-2	How to quick charge	CH-30
Types of charge and how to charge the Li-ion battery	CH-5	Charge connector lock	CH-33
How to normal charge (AC 220-240 volt) by charging device	CH-9	Charging methods	CH-35
How to trickle charge (AC 110-120 volt) by L1 EVSE	CH-11	Charging timer	CH-35
How to trickle charge (AC 110-120 volt) by L1 & L2 EVSE	CH-16	Charging related remote function	CH-37
How to normal charge (AC 220-240 volt) by L1 & L2 EVSE	CH-22	Charging related indicator lights	CH-38
		Charging status indicator light	CH-38
		NISSAN EVSE (Electric Vehicle Supply Equipment) control box indicator light (if so equipped)	CH-39
		Charging troubleshooting guide	CH-41

PRECAUTIONS ON CHARGING

WARNING

- If you use any medical electric devices, such as an implantable cardiac pacemaker or an implantable cardiovascular defibrillator, check with the electric medical device manufacturer concerning the effects that charging may have on implanted devices before starting the charge operation. Charging may affect the operation.
- Make sure there is no water or foreign material in the charge port, charge connector or electrical plug, and that they are not damaged or affected by rust or corrosion. If any of these conditions are noticeable, do not charge the Li-ion battery. This may result in a short circuit or electric shock and could cause a fire which may result in serious personal injury or death.
- To avoid serious personal injury or death when the Li-ion battery is charging, be aware of the following precautions:

- Do not touch the metal contacts of the charge port, charge connector, electrical plug or Genuine NISSAN Adapter.
- Do not touch the vehicle and the EVSE (Electric Vehicle Supply Equipment) (if so equipped) when there is lightning. This may cause an electrical shock.
- Do not pull, twist, bend, step on, or drag the cable.
- Make sure the charge connector is removed from the charge port before starting your vehicle. If the charge connector is only partially engaged and the connector latch is unlocked, it is possible to place the EV in the READY to drive position.
- Do not touch the plug or the Genuine NISSAN Adapter if they are wet or with wet hands. Do not put the plug or the Genuine NISSAN Adapter in water, liquid or snow. This may cause an electric shock which may result in serious personal injury or death.

- Do not disassemble or modify the charge port, the EVSE or the Genuine NISSAN Adapter. This may cause a fire or an electric shock which may result in serious personal injury or death.
- If you notice an unusual odor, smoke or abnormal noises coming from the vehicle, stop charging immediately.
- Be careful not to allow your hands, hair, jewelry or clothing to come into contact with, or get caught in, the traction motor cooling fan. The cooling fan can start at any time during charging.
- It is recommended that you do not use extension cords or adapters unless they are Genuine NISSAN parts or equivalent.
- Do not use the Genuine NISSAN Adapter with any devices except the Genuine NISSAN EVSE.
- Do not allow an unattended child to handle or use this product.
- Use the EVSE with outlet and wiring installed according to the regulations/standards.
- For model with EVSE, after using your EVSE and if you place it in

the vehicle, secure it firmly with the storage in the luggage compartment. See "How to trickle charge (AC 110-120 volt) by L1 EVSE" (P.CH-11), "How to trickle charge (AC 110-120 volt) by L1 & L2 EVSE" (P.CH-16) and "How to normal charge (AC 220-240 volt) by L1 & L2 EVSE" (P.CH-22). Otherwise, it may become a projectile and cause a personal injury during sudden braking or in a collision.

- NISSAN highly recommends you charge your EV at home using a NISSAN recommended dedicated domestic charging station. A SAE J1772-compliant domestic charging station needs to be installed on a dedicated 208-240 V circuit by a professional electrician.



CAUTION

- To prevent damage to the charging equipment:
 - Do not close the charge port lid without closing the charge port cap.

- Do not subject the charging equipment to impact.

- Do not pull or twist the charge cable.

- Make sure to close the charge port lid with the charge port cap closed when charging is finished. If the charge port lid is closed when the charge port cap is open, water or foreign materials may enter the charge port.
- Do not charge when a vehicle body cover is in use. This may cause damage to the charge connector.
- Do not attempt to perform a jump start on the 12-volt battery at the same time when the Li-ion battery is being charged. Doing so may damage the vehicle or charging equipment and could cause an injury. See "Jump starting" (P.6-15).
- Do not insert any object other than the charge connector into the charge port. Doing so may cause damage to the charge port.
- In normal charging (AC 220 - 240 volt) and trickle charging (AC 110 - 120 volt) using the EVSE (Electric

Vehicle Supply Equipment) provided with the vehicle, NISSAN recommends using an AC 220 - 240 volt, 50A and an AC 110- 120 volt, 15A dedicated electrical circuit and outlet. The dedicated circuit is used to help prevent circuit damage or the circuit breaker from tripping due to the high draw of charging the Li-ion battery. If the dedicated circuit is not used, the circuit may cause adverse interference on MCB (Moulded Circuit Board) and household electrical appliances such as televisions and audio systems. If the circuit is shared, and another electrical device is being used at the same time the vehicle is charging, the breaker may trip. A qualified electrician should install a dedicated circuit if one is not already available.







NOTE:

- It may take more time to charge the Li-ion battery using the quick charger if the vehicle is parked in a cold location for a long time. It may take more time to charge the Li-ion battery using the quick charger if the temperature of the Li-ion battery

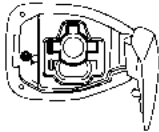
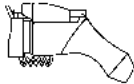

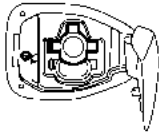

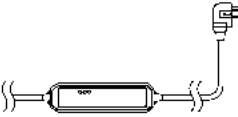
is high or low.

- If the vehicle will not be used for an extended period of time, charge the Li-ion battery once every 3 months.
- The power switch can be placed in the ON position and the climate control can be used while the Li-ion battery is charging. However, because these operations consume Li-ion battery power, it will take longer for the Li-ion battery to become fully charged. Place the power switch in the OFF position to help reduce Li-ion battery charge time.
- If electrical power is interrupted while charging, charging restarts automatically when the electrical power is restored.
- It is recommended to keep the charge cable connected to save Li-ion battery power, when the heater and air conditioner are operating with remote operation (when not waiting for the charging timer).
- If the charge port is frozen, melt the ice. After the ice has melted, charge the Li-ion battery. Forcing the charge connector to connect may cause a malfunction.
- If foreign materials have entered the charge connector or charge port and it is not possible to connect it, do not attempt to force the connection. It is recommended that you visit a NISSAN certified ARIYA dealer. Forcing the charge connector to connect may cause damage to the charging equipment and vehicle.
- There is a hole on the charge port for water drainage. If the water drainage hole becomes blocked, or if water gets trapped inside the charge port, do not charge. It is recommended that you visit a NISSAN certified ARIYA dealer.
- The cooling fan and water pump may start running during charging. This is not a malfunction.

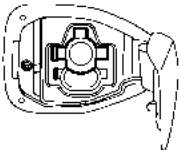
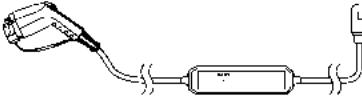

TYPES OF CHARGE AND HOW TO CHARGE THE LI-ION BATTERY

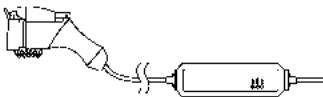
Type of charging	Charge port	Charge connector	Control box	Power	Instructions
AC Level 2: Normal charge (AC 220-240 volt)		 Normal charge connector			Use the charging device (AC 220-240 volt) that is installed in your home
		 Normal charge connector			 Electrical outlet

WBT0154X

Type of charging	Charge port	Charge connector	Control box	Power	Instructions
AC Level 1: Trickle charge (AC 110-120 volt)		 <p>Normal charge connector</p>	 <p>Domestic plug</p>	 <p>Electrical outlet</p>	<p>Use the L1&L2-EVSE Use only a 110-120 volt, 15 amp, dedicated outlet installed by a qualified electrician.</p>
		 <p>Normal charge connector</p>	 <p>Domestic plug</p>	 <p>Electrical outlet</p>	<p>Use the L1-EVSE Use only a 110-120 volt, 15 amp, dedicated outlet installed by a qualified electrician.</p>

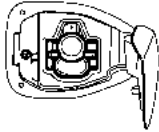
WBT0155X

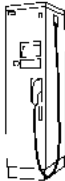
Type of charging	Charge port	Charge connector	Control box	Power	Instructions
DC Level 3: Quick charge		 Quick charge connector			Public charging stations

WBT0156X

This vehicle is an electric vehicle and it requires electricity to operate. The Li-ion battery is the only source of power to operate the vehicle.

It is important to conserve power and plan your charging needs when you drive to avoid completely discharging the Li-ion battery.

There are the following methods of charging the Li-ion battery:

- AC Level 2: Normal charge
- AC Level 1: Trickle charge
- DC Level 3: Quick charge

The time to completely charge the vehicle Li-ion battery varies based on the state of

charge of the Li-ion battery, condition and age of the Li-ion battery, temperature of the Li-ion battery, ambient temperature and condition of the power source connected to the vehicle, and whether the electric equipment (such as the air conditioner, which consumes electric power) is used.

AC Level 2: Normal charge

NISSAN recommends using normal charging for usual charging of the vehicle. Use of quick charge should be minimized in order to help prolong Li-ion battery life.

Normal charging uses L1 & L2 EVSE (Electric Vehicle Supply Equipment), or

an SAE J1772 compliant charging device connected to a dedicated AC 220 - 240 volt circuit. L1 & L2 EVSE is provided with the vehicle (if so equipped). The charging device is a home charging dock installed in your home by a qualified electrician. It is recommended that you visit a NISSAN certified ARIYA dealer. For additional information, see "How to normal charge (AC 220-240 volt) by charging device" (P.CH-9) or "How to normal charge (AC 220-240 volt) by L1 & L2 EVSE" (P.CH-22).

AC Level 1: Trickle charge

Trickle charging is not recommended for regular use because it takes more time

than normal charging. Trickle charge can be used when it is necessary to perform an emergency charge at a destination such as a friend's house.

Trickle charge uses the EVSE (Electric Vehicle Supply Equipment) provided with the vehicle or an SAE J1772 compliant cord set to connect the vehicle to an AC 110-120 volt, 15A dedicated outlet. The outlet should be protected by a circuit breaker to avoid overloading the circuit or other electrical hazard.

For additional information, see "How to trickle charge (AC 110-120 volt) by L1 & L2 EVSE" (P.CH-16) or "How to trickle charge (AC 110-120 volt) by L1 EVSE" (P.CH-11).

DC Level 3: Quick charge

Quick charge capability is only available on vehicles manufactured with the quick charge option, which includes the quick charge port. If your vehicle does not have such a port, quick charging cannot be used.

A vehicle equipped with a quick charge port is compatible with most Combined Charging System (CCS) connectors on charging stations. Charging stations are UL certified and safe to use in the US.

Quick charging is possible (even several times a day). If the battery temperature is near the red zone, in order to protect the

battery, power of the quick charging will be limited.

Public charging:

This vehicle is compatible with any public charging station that is SAE J1772 compliant. If you attempt to charge from a noncompliant charging station, you may not receive a complete charge, or you may not be able to charge at all due to hardware and software differences. NISSAN is working with states, municipalities, utility companies and others to assist in the preparation of markets and infrastructure. However, NISSAN makes no representations that public charging stations will be available in locations where you wish to operate the vehicle, nor can NISSAN predict the period of time it may take for public charging infrastructure to be developed in your area. Depending on where you live or drive, there may not be sufficient public charging stations available to meet your particular needs for driving range and charging away from your home. Trip planning is therefore important, and you should plan trips with these facts in mind.

Even when charging the Li-ion battery using a charger capable of more than 130 kW, the maximum power from the charger will be limited to 130 kW, it will be changed based on the vehicle status.

During charging the power limit to the vehicle may change depending on the capacity of the Li-ion battery. This is normal and does not indicate a malfunction.

The time needed to charge the Li-ion battery from discharged (low battery charge indicator light illuminated) to 80% charged using the quick charger depends on many factors including the Li-ion battery temperature and the type of quick charger used.

It may take more time to charge the Li-ion battery using the quick charger if the vehicle is parked in a cold location for a long time.

It may take more time to charge the Li-ion battery using the quick charger if the temperature of the Li-ion battery is high or low.

NOTE:

If the outside temperature is low and a low temperature alert [] is displayed in the vehicle information display, it is recommended to turn ON "Battery Heater" 30 minutes to 1 hour before arriving at a quick charging station.

Power limitation mode

This mode protects the health and operation of the vehicle's Li-ion battery. This mode operates in certain extreme condi-

tions (heat, cold, low state of charge). Power available to vehicle systems, including its traction motor, is limited resulting in limited performance, acceleration and top speed. Charging may be automatically terminated, especially with repeated quick charging in extreme hot weather.

Checking Li-ion battery charge

The three methods for checking the amount of charge are as follows:

- Check by using the Li-ion battery available charge gauge on the vehicle information display when the power switch is placed in the ON position. For additional information, see “Li-ion battery available charge gauge” (P.2-8) and “Low battery charge warning light” (P.2-17).
- Check by using an internet enabled smart phone using NissanConnect® Services app (if so equipped). For additional information, please visit www.nissanusa.com/connect/.
- Check by using the charging status indicator light. For additional information, see “Charging status indicator light” (P.CH-38).

NOTE:

- **During the charge operation, charge continues when the power switch is**

placed in the ON position.

- **For safety reasons, it is not possible to switch to the READY to drive position while a charge connector is connected.**
- **During charging, it is possible that the radio may be inaudible due to noise by the electromagnetic wave.**

HOW TO NORMAL CHARGE (AC 220-240 volt) BY CHARGING DEVICE



WARNING

- **If you use any medical electric devices, such as an implantable cardiac pacemaker or an implantable cardiovascular defibrillator, check with the electric medical device manufacturer concerning the effects that charging may have on implanted devices before starting the charge operation. Charging may affect the operation.**
- **Be sure to follow the precautions for using the charging device that can be installed in your home. Failing to do so could result in serious injury or death.**



CAUTION

Do not use any charging equipment that is not compatible with the AR-IYA. Doing so could prevent the Li-ion battery from charging properly or could result in damage to the vehicle or Li-ion battery.

- Normal charge uses the charging device (AC 220 - 240 volt, 16A or 32A) that can be installed in your home to charge the Li-ion battery.
- Immediate charge, charging timer and remote charge can be performed in the normal charge mode. For additional information, see “Charging methods” (P.CH-35).
- The charging equipment communicates with the vehicle before Li-ion battery charging starts. If this communication does not occur because other equipment is used, the Li-ion battery will not charge.
- NISSAN recommends that you connect the charging device when getting out of the vehicle, even if it is not going to be used. By doing this, you can get the most out of the remote climate control and Climate Ctrl. Timer functions the next time you use the

vehicle.

To start normal charge:

1. Push the P (Park) position switch to place the vehicle in the P (Park) position and apply the parking brake.
2. When charging the Li-ion battery, place the power switch in the OFF position.
3. Open the charge port lid and charge port cap. For additional lid information, see "Charge port lid" (P.3-27) and "Charge port cap" (P.3-27).

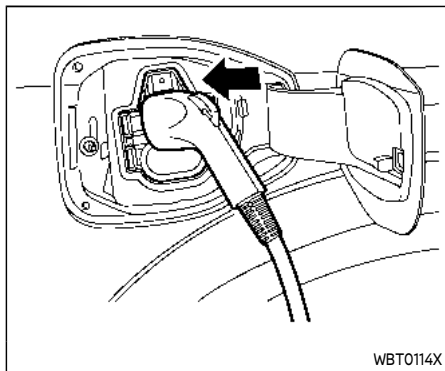

4. Connect the charge connector to the charge port. If it is connected normally, a beep will sound once.
5. If charging has started, a beep will sound twice and the charging status indicator light will operate. For additional information, see "Charging status indicator light" (P.CH-38).

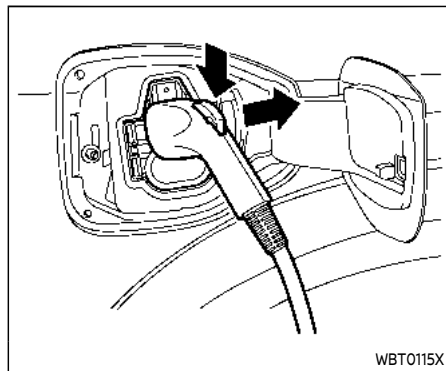

To stop normal charge:

1. Ensure that the charge connector lock is not engaged. For additional information, see "Charge connector lock" (P.CH-33).
2. Press the button on the charge connector, release the lock and remove the charge connector from the charge port and properly store it.

NOTE:

When removing the charge connector, the charge port light will illuminate for approximately 30 seconds. (See "Charge port light" (P.3-28).)

3. Close the charge port cap

4. After closing the charge port cap on the charge port, close the charge port lid.

NOTE:

To stop charging mid-charge, remove the charge connector. Charging automatically stops.

HOW TO TRICKLE CHARGE (AC 110-120 volt) BY L1 EVSE



WARNING

- If you wear a pacemaker or an implantable cardiovascular defibrillator (ICD), stay at least 6 in (15 cm) away from the EVSE.
- If you wear a pacemaker or an implantable cardiovascular defibrillator (ICD), check with the electric medical device manufacturer concerning the effects that charging may have on implanted devices before starting the charge operation. Charging may affect the operation.
- In order to avoid an electric shock or fire due to a short circuit, connect to a GFI (Ground Fault Interrupter) circuit breaker and use a waterproof electrical

ground socket.

- Discontinue EVSE use immediately if plug or outlet becomes hot to the touch or if you notice any unusual odors.
- Never use extension cords or plug adapters with EVSE.
- Always unplug the EVSE when not in use.
- The Genuine NISSAN L1 EVSE charging device draws 12 amps continuously while charging the Li-ion battery with AC 110-120 volt outlet. Do not plug in to any electrical circuit unless it is inspected by a qualified electrician to confirm that the electrical circuit can accept a 12 amp draw. Any electrical circuit has a much higher likelihood of being compromised in the following conditions listed below.
 - Improper use of the EVSE may result in a fire and serious injury or death.
 - Do not use the EVSE in structures more than 40 years old.
 - Do not use the EVSE in structures using fuse-based circuit protection. Use only with elec-

trical circuits protected by circuit breakers.

- Do not use the EVSE on electrical circuits with two-prong outlets.
- Do not use the EVSE if other devices are plugged into the same circuit.
- When unplugging, be sure to pull by the plug or the EVSE, not the cord.
- Do not pull, twist, bend, step on or drag the cable.
- Do not attach or detach the Genuine NISSAN Adapter while the Genuine NISSAN Adapter is inserted into an outlet.
- Do not use the Genuine NISSAN Adapter if the plug is not fully inserted and not locked.
- If you use the EVSE holder, handle it with care to avoid injuries due to contact with its edges or other parts.
- Do not use the EVSE if the cable or cord is frayed, has broken insulation, or shows any other indications of da-

mage.

- Stop using the EVSE immediately if charging stops before completion when you move the plug or cord.
- Do not use the EVSE if the control box, plug, the EVSE or charge connector is broken, cracked, open, corroded or shows any other indications of damage.
- Do not use the EVSE if the plug has a loose connection with the outlet or if the outlet is damaged or rusted.
- Before you connect the EVSE, be sure to check the rated current shown on the EVSE to ensure that the outlet and circuit have enough current capacity to charge your vehicle safely. If the capacity of the outlet and circuit is not enough, wiring may cause overheating or a fire.
- If in any doubt about the outlet and circuit, consult a qualified electrician.

- The EVSE has parts that may spark inside. Do not use it where gasoline, paint, or flammable liquids are used or stored.
- Do not use if a malfunction occurs or if the EVSE has been damaged in any manner. It is recommended that you visit a NISSAN certified ARIYA dealer for replacement.
- The EVSE contains no user serviceable parts. Do not attempt to repair the EVSE, doing so will void your warranty.



CAUTION

- Only charge using a standard AC 110 - 120 volt, 15A dedicated electrical outlet (for example, do not use an electric generator). Failure to do so may cause charging to fail and could cause damage to the vehicle or the EVSE equipment due to power surges.
- NISSAN recommends using Genuine NISSAN charging equipment

to charge the vehicle. Using non-NISSAN equipment could cause the Li-ion battery to not charge correctly and may damage the vehicle.

Precautions on storage

- Do not store the EVSE in a place exposed to direct sunlight.
- Do not store the EVSE in a place exposed to wind or rain.
- Be sure to store the EVSE with the protective cap on to keep the terminal of the charge connector away from dirt and dust.
- Do not store the EVSE with the cable and/or cord wound around the control box.
- Do not store the EVSE in a condition in which the cable and/or cord are twisted.
- The control box will become hot while the EVSE is charging. This is not a malfunction.

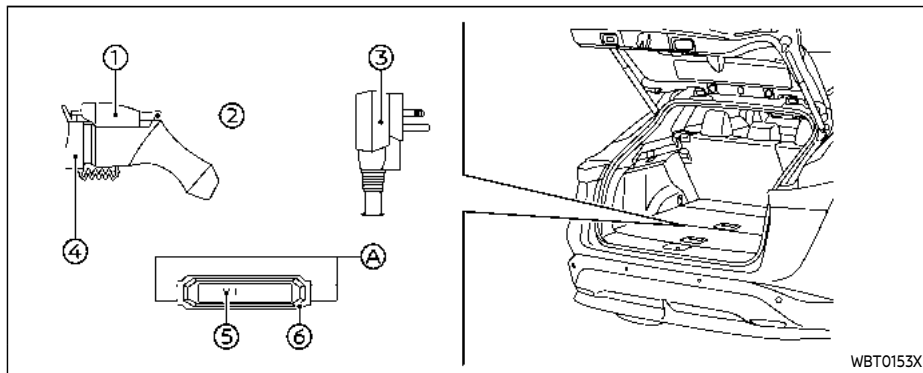

- ①: Charge Connector
- ②: Release Button
- ③: Plug
- ④: Safety cap
- ⑤: Indicator light
- ⑥: Control box

To start trickle charging:

NOTE:

Charging timer, remote charge and immediate charge can be performed in the trickle charge mode. For additional information, see "Charging methods" (P. CH-35).

1. Push the P (Park) position switch to place the vehicle in the P (Park) position and apply the parking brake.
2. When charging the Li-ion battery, place the power switch in the OFF position.
3. Open the charge port lid. For additional information, see "Charge port lid" (P.3-27).
4. Take out the EVSE from the luggage compartment.
5. Connect the electrical plug to the AC 110 - 120 volt, 15A dedicated electrical outlet. If it is connected normally, the green light on the EVSE control box indicator light illuminates.

NOTE:

You can pass a cord through the holes ④ in the control box in order to hang it up while the Li-ion battery is charging. Use the EVSE with the plug in an upright position (the cord should extend down from the outlet).

6. Open the charge port cap. For additional information, see "Charge port cap" (P.3-27).

WBT0153X

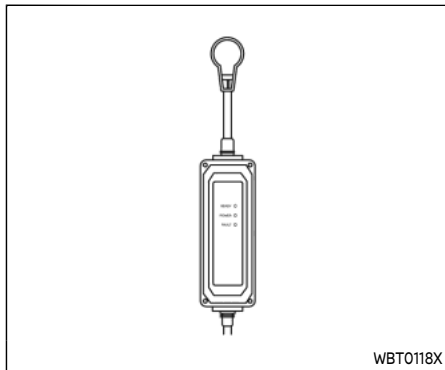

7. Remove the safety cap from the charge connector.
8. Connect the charge connector to the charge port. If it is connected normally, a beep will sound once.
9. If charging has started, a beep will sound twice and the charging status indicator light will operate. For additional information, see "Charging status indicator light" (P.CH-38).

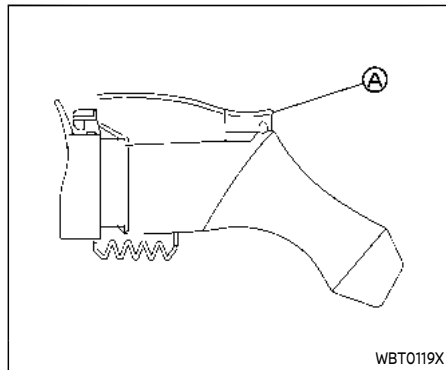
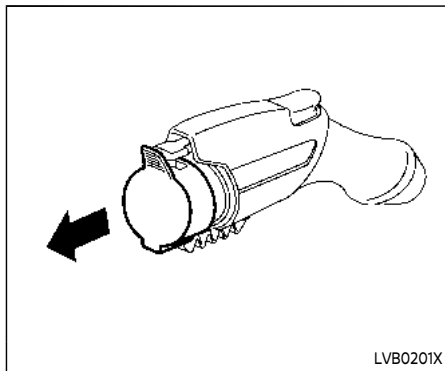

10. When recharging outside, such as in your driveway, use a commercially available padlock attached in position **A** to prevent theft.

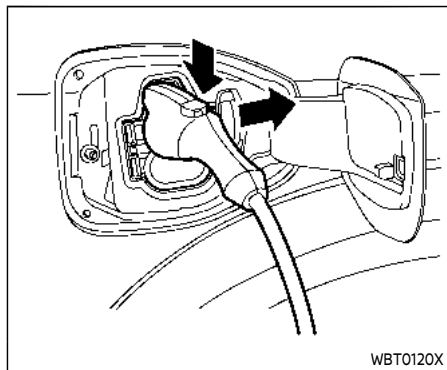

To stop trickle charge:

1. Ensure that the charge connector lock is not engaged. For additional information, see "Charge connector lock" (P.CH-33).
2. Press the button on the charge connector, release the lock and remove the charge connector from the charge port.

NOTE:

When removing the charge connector, the charge port light will illuminate for approximately 30 seconds. (See "Charge port light" (P.3-28).)

3. Close the charge port cap.

4. Attach the safety cap to the EVSE.
5. Remove the electrical plug from the AC 110 - 120 volt, 15A dedicated electrical outlet.
6. Store in its case.

NOTE:

Perform the following procedure to store the EVSE in the case:

- a. Wind the charge cable into a size that will allow it to be stored in the case (approximately 12 in (30 cm) in diameter). Winding the charge cable in the direction shown below avoids shortening of cable life.

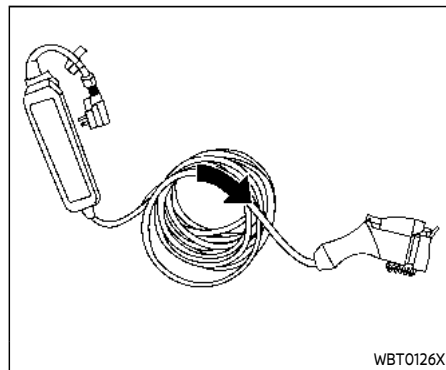

Example

- b. Place the EVSE into the case.

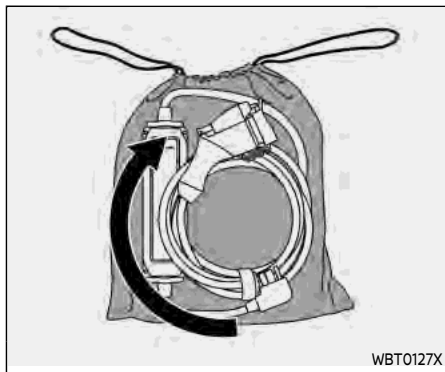

Example

c. Store the case in the luggage compartment.

7. After closing the cap on the charge port, close the charge port lid.

NOTE:

To stop charging mid-charge, remove the charge connector. Charging automatically stops.

HOW TO TRICKLE CHARGE (AC 110-120 volt) BY L1 & L2 EVSE

WARNING

- If you wear a pacemaker or an implantable cardiovascular defibrillator (ICD), stay at least 6 in (15 cm) away from the EVSE.
 - If you use any medical electric devices, such as an implantable cardiac pacemaker or an Implantable Cardiovascular Defibrillator (ICD), check with the electric medical device manufacturer concerning the effects that charging may have on implanted devices before starting the charge operation. Charging may affect the operation.
 - In order to avoid an electric shock or fire due to a short circuit, connect to a GFI (Ground Fault Interrupter) circuit breaker and use a water proof electrical ground socket.
 - Discontinue EVSE use immediately if plug or outlet becomes hot to the touch or if you notice any unusual odors.
- Never use extension cords.
 - Never use plug adapters other than the Genuine NISSAN Adapter for EVSE.
 - Always unplug the EVSE when not in use.
 - The Genuine NISSAN L1 & L2 EVSE draws 12 amps continuously while charging the Li-ion battery with AC 110–120 volt outlet. Do not plug in to any electrical circuit unless it is inspected by a qualified electrician to confirm that the electrical circuit can accept a 12 amp draw. Any electrical circuit has a much higher likelihood of being compromised in the following conditions listed below.
 - Improper use of the EVSE may result in a fire and serious injury or death.
 - Do not use the EVSE in structures more than 40 years old.
 - Do not use the EVSE in structures using fuse-based circuit protection. Use only with electrical circuits protected by circuit breakers.
 - Do not use the EVSE on electrical circuits with two-prong

outlets.

- Do not use the EVSE if other devices are plugged into the same circuit.
- When unplugging, be sure to pull by the plug or the Genuine NISSAN Adapter, not the cord.
- Do not pull, twist, bend, step on or drag the cable.
- Do not attach or detach the Genuine NISSAN Adapter while the Genuine NISSAN Adapter is inserted into an outlet.
- Do not use the Genuine NISSAN Adapter if the plug is not fully inserted and not locked.
- If you use the EVSE holder, handle it with care to avoid injuries due to contact with its edges or other parts.
- Do not use the EVSE or Genuine NISSAN Adapter if the cable or cord is frayed, has broken insulation, or shows any other indications of damage.

- Stop using the EVSE or Genuine NISSAN Adapter immediately if charging stops before completion when you move the Genuine NISSAN Adapter, the plug or the cord.
- Do not use the EVSE or Genuine NISSAN Adapter if the control box, plug, Genuine NISSAN Adapter or charge connector is broken, cracked, open, corroded or shows any other indications of damage.
- Do not use the EVSE or Genuine NISSAN Adapter if the plug or Genuine NISSAN Adapter has a loose connection with the outlet or if the outlet is damaged or rusted.
- Before connecting the EVSE, be sure to check the rated current shown on the EVSE to ensure that the outlet and circuit have enough current capacity to charge your vehicle safely. If the capacity of the outlet and circuit is not enough, wiring may cause overheating or a fire.

- If in any doubt about the outlet and circuit, consult a qualified electrician.
- The device has parts that may spark inside. Do not use it where gasoline, paint, or flammable liquids are used or stored.
- Do not use if a malfunction occurs or if the EVSE or Genuine NISSAN Adapter has been damaged in any manner. It is recommended that you visit a NISSAN certified ARIYA dealer for replacement.
- The EVSE or Genuine NISSAN Adapter contains no user serviceable parts. Do not attempt to repair the EVSE or Genuine NISSAN Adapter, doing so will void your warranty.



CAUTION

- Only charge using a standard AC 110 - 120 volt, 15A dedicated electrical outlet (for example, do not use an electric generator). Failure to do so may cause char-

ging to fail and could cause damage to the vehicle or the EVSE due to power surges.

- NISSAN recommends using Genuine NISSAN charging equipment to charge the vehicle. Using non-NISSAN equipment could cause the Li-ion battery to not charge correctly and may damage the vehicle.

Precautions on storage

- Do not store the EVSE and Genuine NISSAN Adapter in a place exposed to direct sunlight.
- Do not store the EVSE and Genuine NISSAN Adapter in a place exposed to wind or rain.
- Be sure to store the EVSE with the protective cap on to keep the terminal of the charge connector away from dirt and dust.
- Do not store the EVSE with the cable and/or cord wound around the control box.
- Do not store the EVSE in a condition in which the cable and/or cord are twisted.
- The control box will become hot while the EVSE is charging. This is not a malfunction.

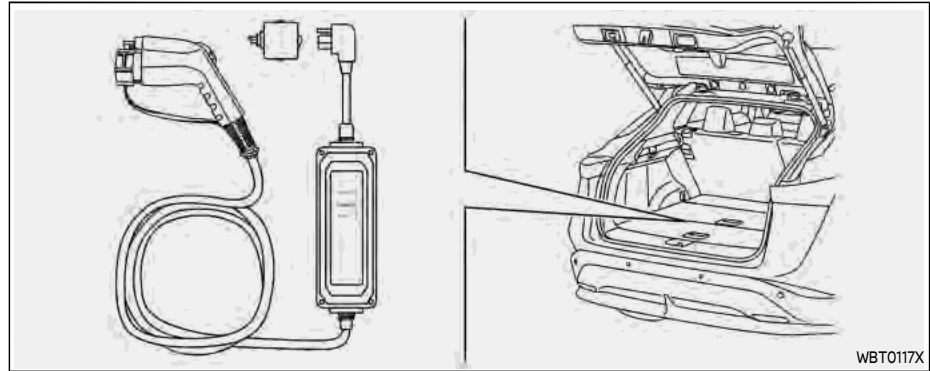

To start trickle charging:

NOTE:

Charging timer, remote charge and immediate charge can be performed in the trickle charge mode. For additional information, see "Charging methods" (P. CH-35).

1. Push the P (Park) position switch to place the vehicle in the P (Park) position and apply the parking brake.
2. When charging the Li-ion battery, place the power switch in the OFF position.
3. Open the charge port lid. For additional information, see "Charge port

lid" (P.3-27).

4. Take out the EVSE from the luggage compartment.
5. Connect the electrical plug to the AC 110 - 120 volt, 15A dedicated electrical outlet. If it is connected normally, the green light on the EVSE control box indicator light illuminates.

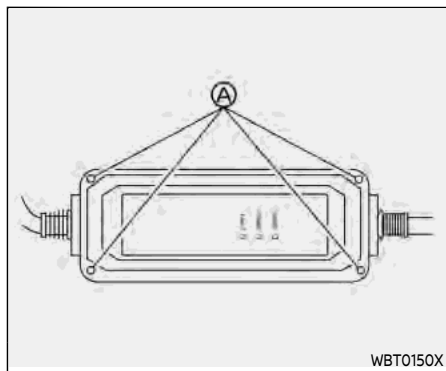

NOTE:

You can pass a cord through the holes **A** in the control box in order to hang it up while the Li-ion battery is charging. Use the EVSE with the plug in an upright position (the cord should extend down from the outlet).

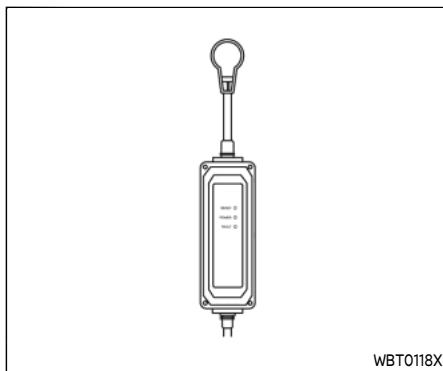

6. Open the charge port cap. For additional information, see "Charge port cap" (P.3-27).

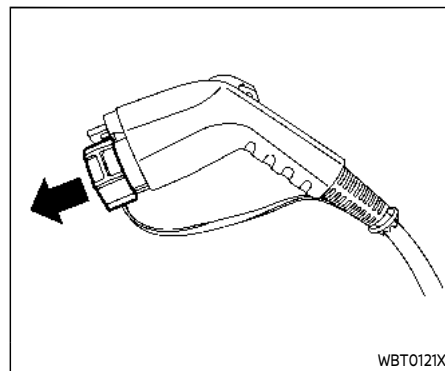

7. Remove the safety cap from the charge connector.

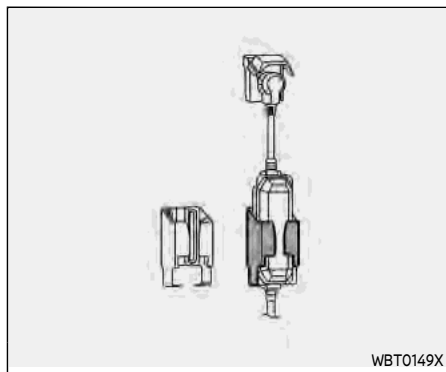

8. Connect the charge connector to the charge port. If it is connected normally, a beep will sound once.
9. If charging has started, or if the Li-ion battery is waiting for the charging timer, a beep will sound twice and the charging status indicator light will operate. For additional information, see "Charging status indicator light" (P.CH-38).

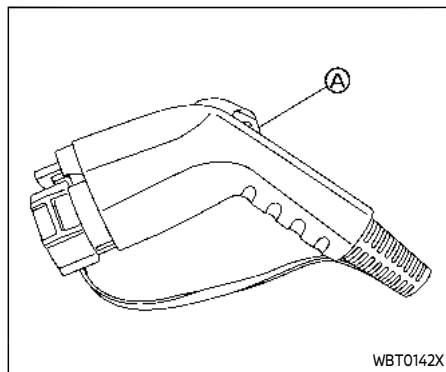
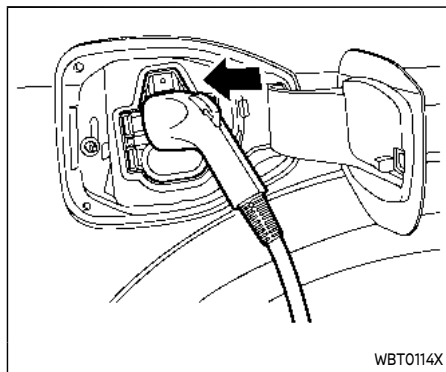

10. When recharging outside, such as in your driveway, use a commercially available padlock attached in position **A** to prevent theft.

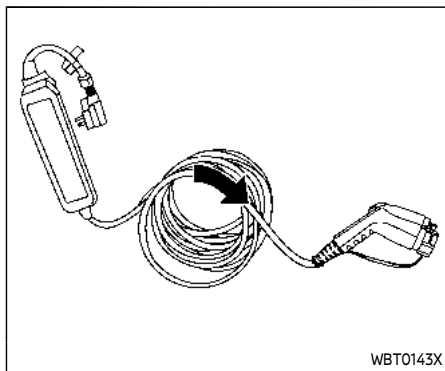
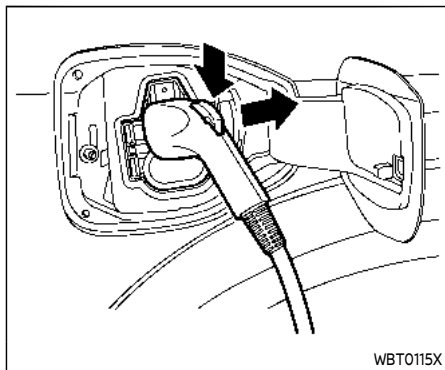

To stop trickle charge:

1. Ensure that the charge connector lock is not engaged. For additional information, see "Charge connector lock" (P.CH-33).
2. Press the button on the charge connector, release the lock and remove the charge connector from the charge port.

NOTE:

When removing the charge connector, the charge port light will illuminate for approximately 30 seconds. (See "Charge port light" (P.3-28).)

3. Attach the safety cap to the EVSE.
4. Remove the electrical plug from the AC 110 - 120 volt, 15A dedicated electrical outlet.

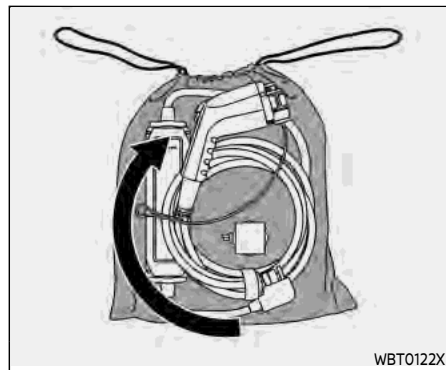

5. Store in its case.

NOTE:

Perform the following procedure to store the EVSE in the case:

1. Wind the charge cable into a size that will allow it to be stored in the case (approximately 12 in (30 cm) in diameter). Winding the charge cable in the direction shown above avoids shortening of cable life.
2. Place the EVSE into the case.
3. Store the case in the luggage compartment.
4. After closing the cap on the charge port, close the charge port lid.

NOTE:

To stop charging mid-charge, remove the charge connector. Charging automatically stops.

HOW TO NORMAL CHARGE (AC 220–240 volt) BY L1 & L2 EVSE



WARNING

Please be sure to follow the warnings below. Failure to do so may result in serious injury or death.

- If you wear a pacemaker or an implantable cardiovascular defibrillator (ICD), stay at least 6 in (15 cm) away from the EVSE.
- If you use a pacemaker or an Implantable Cardiovascular Defibrillator (ICD), check with the electric medical device manufacturer concerning the effects that charging may have on implanted devices before starting the charge operation. Charging may affect the operation.
- In order to avoid an electric shock or fire due to a short circuit, connect to a GFI (Ground Fault Interrupter) circuit breaker and use a water proof electrical

ground socket.

- Discontinue EVSE use immediately if plug or outlet becomes hot to the touch or if you notice any unusual odors.
- Never use extension cords or plug adapters with EVSE.
- Never use plug adapters other than the Genuine NISSAN Adapter for EVSE.
- Always unplug the EVSE when not in use.
- The Genuine NISSAN L1 & L2 EVSE draws 30 amps continuously while charging the Li-ion battery with AC 220–240 volt outlet. Do not plug in to any electrical circuit unless it is inspected by a qualified electrician to confirm that the electrical circuit can accept a 30 amp draw. Any electrical circuit has a much higher likelihood of being compromised in the following conditions listed below.
 - Improper use of the EVSE may result in a fire and serious injury or death.
 - Do not use the EVSE in structures more than 40 years old.

- Do not use the EVSE in structures using fuse-based circuit protection. Use only with electrical circuits protected by circuit breakers.
- Do not use the EVSE on electrical circuits with two-prong outlets.
- Do not use the EVSE if other devices are plugged into the same circuit.
- When unplugging, be sure to pull by the plug and not the cord.
- Do not pull, twist, bend, step on or drag the cable.
- If you use the EVSE holder, handle it with care to avoid injuries due to contact with its edges or other parts.
- Do not use the EVSE if the cable or cord is frayed, has broken insulation, or shows any other indications of damage.
- Stop using the EVSE immediately if charging stops before completion when you move the plug or the cord.

- Do not use the EVSE if the control box, plug, the EVSE or charge connector is broken, cracked, open, corroded or shows any other indications of damage.
- Do not use the EVSE if the plug has a loose connection with the outlet or if the outlet is damaged or rusted.
- Before you connect the EVSE, be sure to check the rated current shown on the EVSE to ensure that the outlet and circuit have enough current capacity to charge your vehicle safely. If the capacity of the outlet and circuit is not enough, wiring may cause overheating or a fire.
- If in any doubt about the outlet and circuit, consult a qualified electrician.
- The EVSE has parts that may spark inside. Do not use it where gasoline, paint, or flammable liquids are used or stored.
- Do not use if a malfunction occurs or if the EVSE has been

damaged in any manner. It is recommended that you visit a NISSAN certified ARIYA dealer for replacement.

- The EVSE contains no user serviceable parts. Do not attempt to repair the EVSE, doing so will void your warranty.



CAUTION

- Only charge using a standard AC 220 - 240 volt, 50A dedicated electrical outlet (for example, do not use an electric generator). Failure to do so may cause charging to fail and could cause damage to the vehicle or the EVSE due to power surges.
- NISSAN recommends using Genuine NISSAN charging equipment to charge the vehicle. Using non-NISSAN equipment could cause the Li-ion battery to not charge correctly and may damage the vehicle or the EVSE.

Precautions on storage

- Do not store the EVSE in a place exposed to direct sunlight.
- Do not store the EVSE in a place exposed to wind or rain.
- Be sure to store the EVSE with the protective cap on to keep the terminal of the charge connector away from dirt and dust.
- Do not store the EVSE with the cable and/or cord wound around the control box.
- Do not store the EVSE in a condition in which the cable and/or cord are twisted.
- The control box will become hot while the EVSE is charging. This is not a malfunction.
- Normal charge (AC 220-240 volt) by L1 & L2 EVSE is performed using an AC 220 – 240 volt, 50A dedicated electrical outlet using the L1 & L2 EVSE provided with the vehicle.

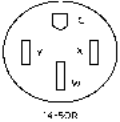
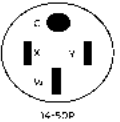
Description	NEMA No.	Amperes	Outlet	Plug
3-POLE 4-WIRE GROUNDING	14	50A		

WBT0134X

NEMA 14-50 outlet and plug

- 120V/240V EVSE (L1/L2) plug must be connected to a NEMA 14-50 outlet that is connected to a single phase power supply obtained from a delta connection.
- If connected to another type of power supply, EVSE will not work normally.

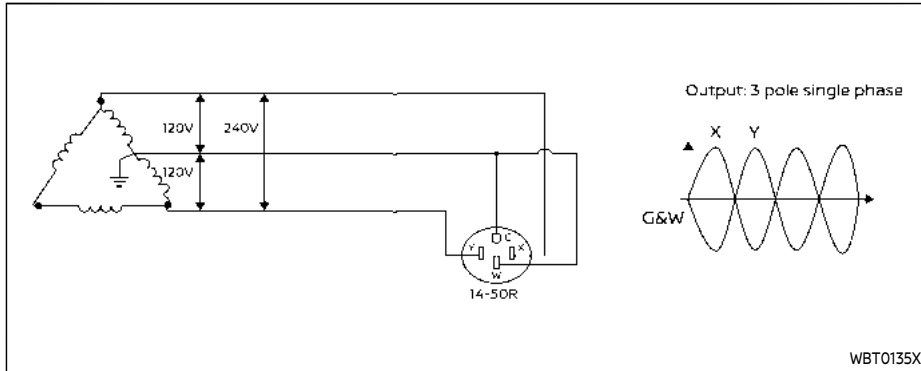

WBT0135X

Correct electric outlet connection If connected to three phase power supply, EVSE does not work normally.

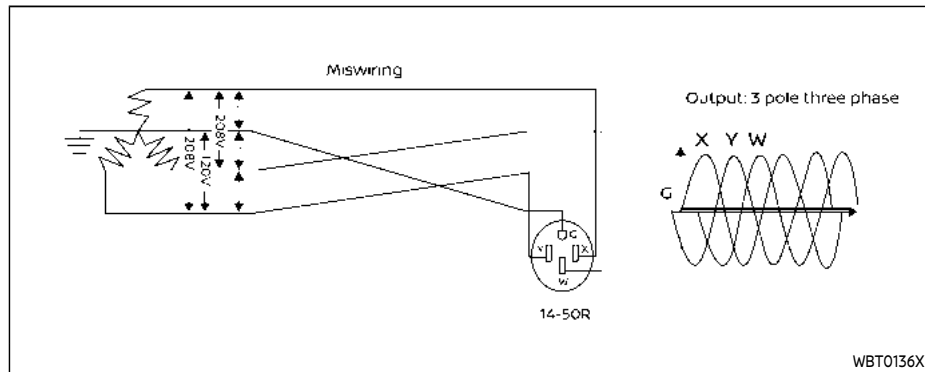

Incorrect electric outlet connection if EVSE is connected to this miswired outlet, EVSE does not work and the POWER indicator light (orange) on the EVSE control box will blink.

To start normal charging

NOTE:

Charging timer, remote charge and immediate charge can be performed in the normal charge mode. For additional information, see "Charging methods" (P. CH-35).

1. Push the P (Park) position switch to place the vehicle in the P (Park) position and apply the parking brake.
2. When charging the Li-ion battery, place the power switch in the OFF position.

3. Open the charge port lid. For additional information, see "Charge port lid" (P.3-27).

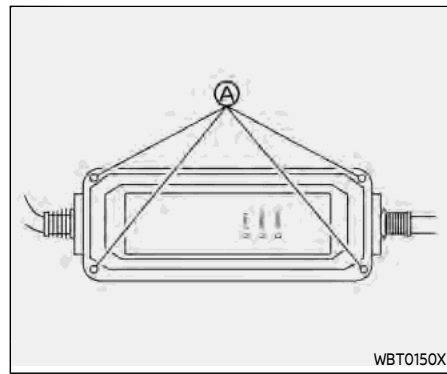
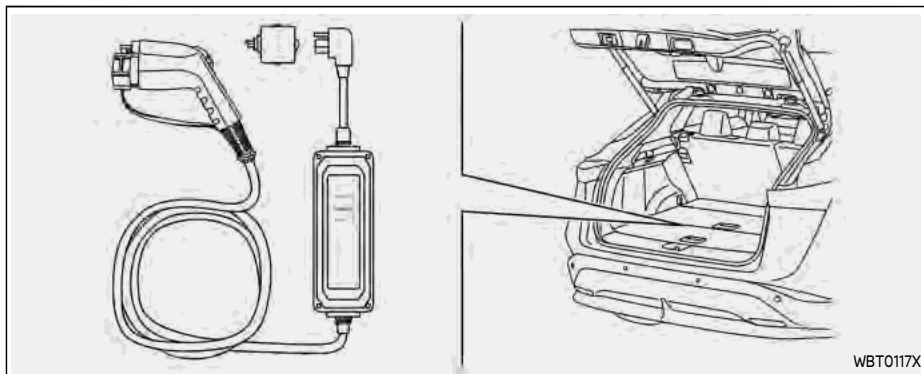

4. Take out the EVSE from the luggage compartment.
5. Connect the electrical plug to the AC 220 - 240 volt, 50A dedicated electrical outlet. If it is connected normally, the green light on the EVSE control box indicator light illuminates.

NOTE:

You can pass a rope through the holes Ⓐ on the control box or place the control box to the holder in order to hang it up while the Li-ion battery is charging. Use the EVSE with the plug in an upright position. (The cord should extend down from the outlet.)

6. Open the charge port cap. For additional information, see "Charge port cap" (P.3-27).

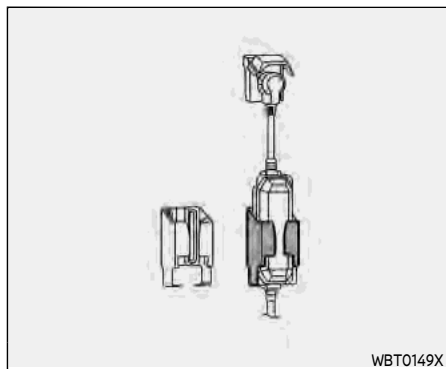

7. Remove the safety cap from the charge connector.

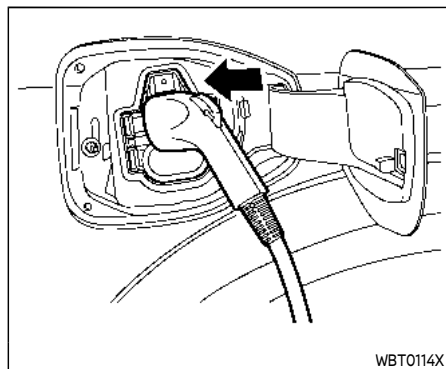

8. Connect the charge connector to the charge port. If it is connected normally, a beep will sound once.
9. If charging has started, a beep will sound twice and the charging status indicator light will operate. For additional information, see "Charging status indicator light" (P.CH-38).

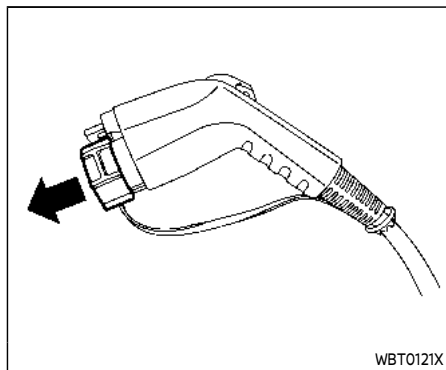

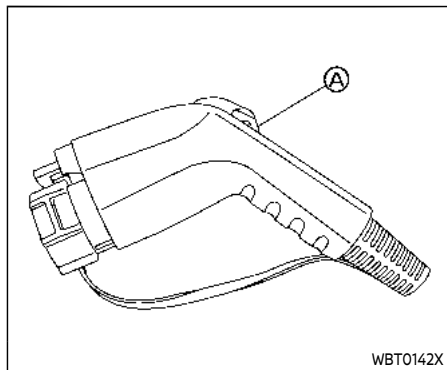

10. When recharging outside, such as in your driveway, use a commercially available padlock attached in position **A** to prevent theft.

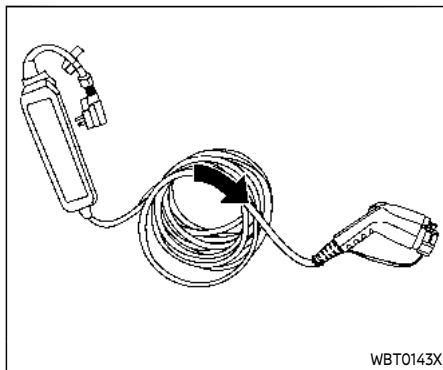

To stop normal charging:

1. Ensure that the charge connector lock is not engaged. For additional information, see "Charge connector lock" (P.CH-33).

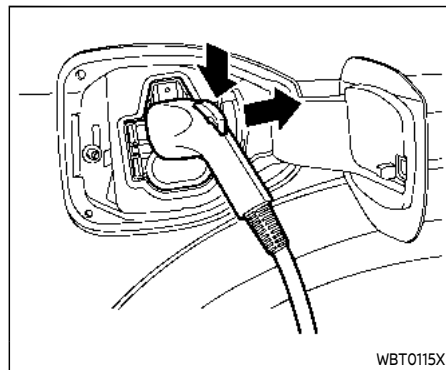

2. Press the button on the charge connector, release the lock and remove the charge connector from the charge port.
3. Attach the safety cap to the EVSE.
4. Remove the electrical plug from the AC 220 - 240 volt, 50A dedicated electrical outlet.

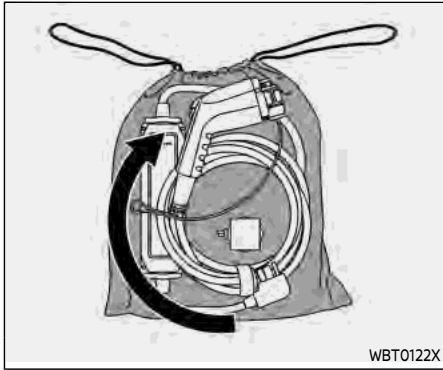

5. Store in its case.

NOTE:

Perform the following procedure to store the EVSE in the case:

1. Wind the charge cable into a size that will allow it to be stored in the case (approximately 12 in (30 cm) in diameter). Winding the charge cable in the direction shown above avoids shortening the cable life.
2. Place the EVSE into the case.
3. Store the case in the luggage compartment.
4. After closing the cap on the charge port, close the charge port lid.

CH-30 **Charging**

WARNING

To stop charging mid-charge, remove the charge connector. Charging automatically stops.

HOW TO QUICK CHARGE

Even when charging the Li-ion battery using a charger capable of more than 130 kW, the maximum power from the charger will be limited to 130 kW, it will be changed based on the vehicle status.

It may take more time to charge the Li-ion battery using the quick charger if the temperature of the Li-ion battery is high or low.

WARNING

- **Always use a quick charger that is compatible with this vehicle. Using an incompatible quick charger may cause a fire or malfunction resulting in serious personal injury or death.**
- **Before starting the quick charge, carefully read the instructions provided on the quick charger and make sure the quick charge**

connector is properly connected and locked to the vehicle. Failure to connect or operate the quick charger correctly could cause damage to the vehicle or the charging equipment.

CAUTION

- **The electric vehicle is equipped with charging safeguards to protect the battery if it reaches a certain temperature level leading to a longer charging time.**
- **Charge time depends on charging conditions, including charger type and condition, battery temperature, Li-ion battery temperature control system (if so equipped) activation status and ambient temperature.**
- **Time taken for successive quick charges will be longer if the battery temperature activates the battery safeguarding technology.**

NOTE:

- When the Li-ion battery available charge and Li-ion battery capacity are shown on the quick charger unit, the readings may differ from the actual Li-ion battery available charge/capacity.
- Depending on the quick chargers, the operation may differ from the one shown in this manual. Follow the instructions provided on the quick charger.

How to start quick charge

1. Push the park button to place the vehicle in the P (Park) position, and apply the parking brake.
2. Place the power switch in the OFF position.
3. The charge port lid is linked to the door locking mechanism of the vehicle.

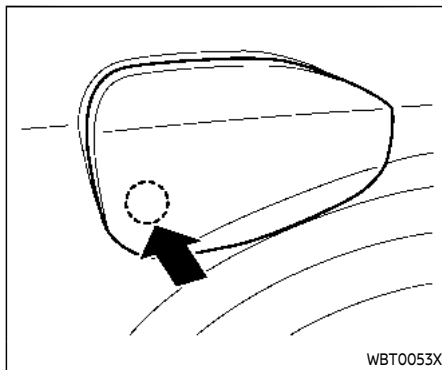

To open the charge port lid, unlock the doors (see "Intelligent Key system" (P.3-6)) and push the rear part of the lid as illustrated. Then open the charge port cap. (See "Charge port lid" (P.3-27).)

4. Follow the instructions on the quick charge equipment, insert the charge connector all the way in.

charging or could cause damage to the charging equipment.



CAUTION

Be sure to insert the charge connector straight into the quick charge port all the way in. Failure to do so may result in the Li-ion battery not

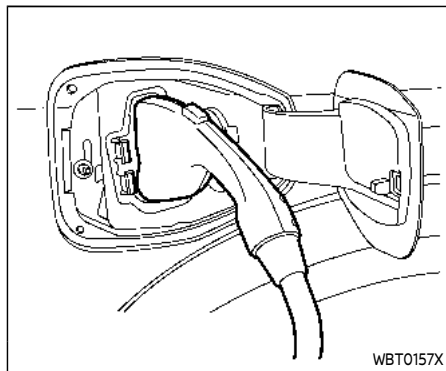

5. Follow the instructions on the quick charge equipment to start charging. When the equipment is properly installed and ready to charge, a beep sounds twice and the charging status indicator light will operate. See "Charging status indicator light" (P.CH-38).

Charging ends in the following situations:

- When charging is complete.
- When the possible charge time set for the quick charger is exceeded.

NOTE:

- **Charging may automatically stop even if it is not completed.**

- If charging stops mid-charge, you can restart charging by pushing the start button on the quick charger station again.
- The charge connector is locked to the charge port after it is connected and cannot be disconnected. Follow the instructions on the quick charge equipment to stop charging. Confirm charging is stopped by looking at the charging status indicator light on the instrument panel. The charge connector can be disconnected from the vehicle when charging has stopped.
- When quick charging, the Li-ion battery charging rate is slower as the percentage of available battery charge increases.
- When quick charging, the Li-ion battery charging rate is slower when the Li-ion battery temperature is extremely high or low.

How to stop quick charge

1. Confirm charging is stopped by looking at the charging status indicator light on the instrument panel. The charge connector can be disconnected from the vehicle when charging is stopped.

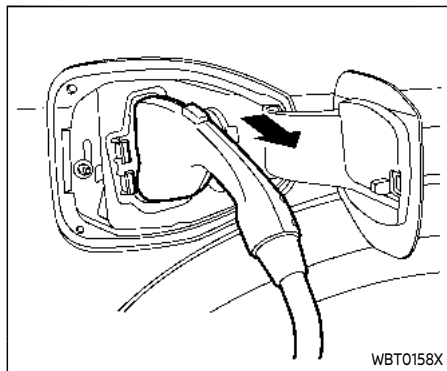

2. Remove the charge connector from the vehicle and store it away properly.

NOTE:

- The charge connector cannot be unlocked after it is connected. To unlock the charge connector without starting to charge, wait a few minutes or stop the quick charger.

- When removing the charge connector, the charge port light will illuminate for about 30 seconds. (See "Charge port light" (P.3-28).)

3. Close the charge port cap.
4. Close the charge port lid.



CAUTION

As the quick charge connector is heavier in comparison to the other charge connectors, allowing it to drop could cause damage to the vehicle or charge connector or personal injury. When removing the connector, be sure to pull it out straight and as carefully as possible.

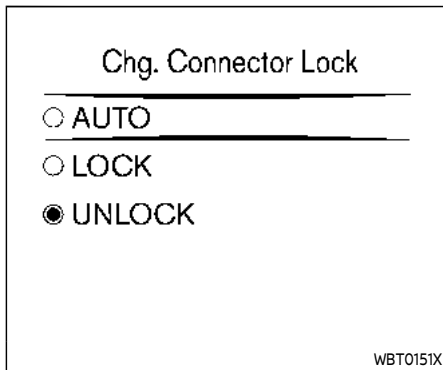

CHARGE CONNECTOR LOCK

The normal or trickle charge connector can be locked to the normal charge port. Perform the following steps and the charge connector lock mode can be selected:

1. Push the ◀ ▶ button until "Settings" appears in the vehicle information display and then push the scroll dial. Use the scroll dial to select "EV Settings". Then push the scroll dial.
2. Select "Chg. Connector Lock" and push the scroll dial.
3. Select the preferred mode of "AUTO", "LOCK" or "UNLOCK" and push the

scroll dial.

NOTE:

- The charge connector lock can be activated when the vehicle is in the P (Park) position and the charge connector is connected. The charge connector lock will not be activated if the charge connector is not properly connected.
- If the charge connector is not correctly connected, the charging status indicator light will flash in red and a beep will sound three times for 30 seconds. (See "Charging status indicator light" (P.CH-38).)

AUTO mode

When AUTO mode is selected, the charge connector is locked while charging is in process. The charge connector will be unlocked automatically when charging is stopped.

When the plug of the charge cable is not connected to the outlet, the normal charge connector is locked when connected.

LOCK mode

When LOCK mode is selected, the charge connector will remain locked. The charge connector will be unlocked when UNLOCK mode is selected.

Before the plug of the charge cable is connected to the outlet, if the normal charge connector is connected, the connector may not be locked while charging. If the charge connector is not locked, insert and remove the connector.

UNLOCK mode

When UNLOCK mode is selected, the charge connector will remain unlocked.

When the normal charge connector is connected, the connector is locked and will be unlocked after a few seconds.

Unlock operation

To unlock the charge connector lock, unlock the vehicle's door from the locked state. The charge connector lock is unlocked for 30 seconds.

After 30 seconds, the charge connector lock is locked again.

NOTE:

- Depending on the charging station, the lock mechanism established by local standards may not be compatible with your vehicle. It may not be

possible for the charge connector to lock to your vehicle.

- When the power source is cut off in the event of a power outage, etc. while charging in AUTO mode, the connector will be unlocked. After power recovery, the charge connector lock is locked again.
- When timer charging is set with AUTO mode, the connector will not lock until charging is started.
- When the following system(s) are operated individually or the 12-volt battery is being charged, the charging connector lock will not lock:
 - Climate Ctrl. Timer
 - Remote climate control
 - Li-ion battery temperature control system

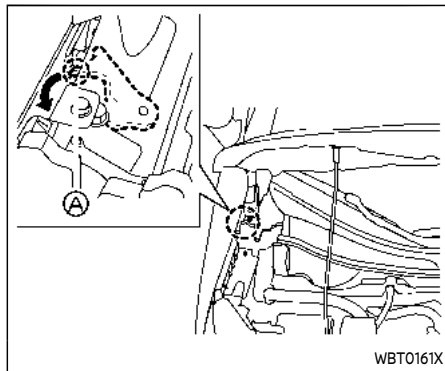

If the charge connector cannot be unlocked



CAUTION

Do not unlock the charge connector using the screw as illustrated when the charge connector lock is operated normally.

If the charge connector cannot be unlocked, proceed as follows:

1. Place the power switch in the OFF position.

- Open the hood.
- Locate a white colored lever (A) on the upper side of the connector lock actuator.
- Insert a flat-blade screwdriver or suitable tool and turn the lever counter-clockwise until the lever stops to release the charge connector.
- Remove the charge connector from the charge port.

CHARGING METHODS

CHARGING TIMER

Use charging timer to schedule when the Li-ion battery charges. You can save three timer settings that include the charging start time and end time. The timer settings can be applied to each day of the week. The vehicle automatically begins charging at the scheduled times when the charge connector is connected to the vehicle. The timers do not need to be reset each time the Li-ion battery needs to be charged.

How to set charging timer

The charging timer settings can be changed with the touch screen display.

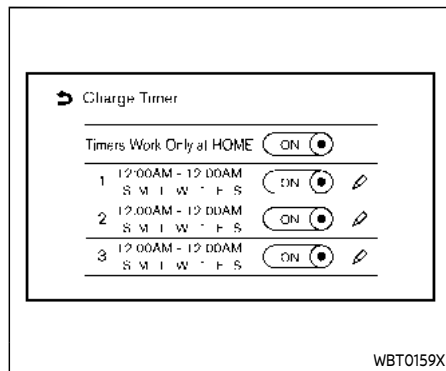

- Touch the "Home" key on the Launch bar.
- Touch the "All Apps" key and then touch "EV" key.
- Touch "Charge Timer" key. Charging Timer screen is displayed.

Available actions:

- Timers Work Only at Home:**

When this item turns on, charging timer works only at home.

- Timer settings:**

Touch to turn on/off the timer. The indicator light will turn on when the timer setting is turned on.

- "Pencil" key:**

Touch to display the charging timer

settings screen. Set preferred time and day of the week for vehicle charging. (See "Charging timer setting screen" (P.CH-36).)

4. After completing the settings, place the power switch in the OFF position, and then connect the charge connector to the vehicle.

Charging timer setting screen

Three different timer setting can be registered.

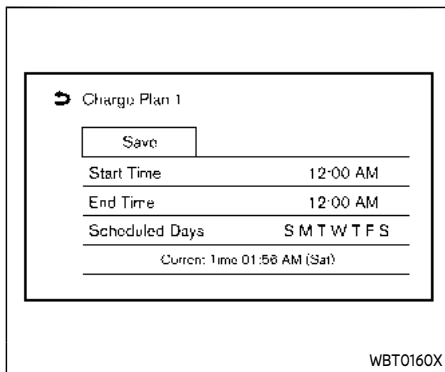

1. Touch to change the start time.
2. Touch to change the end time.
3. Touch to change the weekly schedule.
4. Touch to save the settings.

Operating tips for charging timer

- Charging timer is performed according to the current time setting on the display. When setting the charging timer function, be sure to check that the current time displayed is correct.
- The Li-ion battery may not be fully charged if the charging timer start time and end time are set such that there is not enough time to charge the Li-ion battery.
- To turn off the charging timer function, touch [ON] on the charging timer setting screen until the indicator lights are turned off. After this operation has been performed, the charging timer function is turned off. The start and stop time settings are not deleted, even if the charging timer function is turned off.
- If the day of the week is not selected on the charging timer setting screen, the charging timer will not operate on that day. The system will wait until the next set charging time to perform charging.
- The timer setting can be changed while charging timer is in operation. When the setting is changed while charging timer is in operation, the new settings are applied immediately.
- The Li-ion battery will not charge when the charge connector is connected to the vehicle until the next scheduled charge start time when the charging timer is active. If necessary, use immediate charge or remote charge (if so equipped) to charge the Li-ion battery.
- Some charging stations used to perform normal charge are equipped with timer functions. If the charger timer function and the vehicle timer

are both set, and the two timers are not set to operate at the same time, it is possible that the charger will not start or that the Li-ion battery will not be fully charged.

- The Li-ion battery may not be fully charged or the charging time may be longer when the Li-ion battery temperature control system (if so equipped) or the air conditioning system operates while charging using the Charging Timer.
- Li-ion battery electricity will be consumed if the Li-ion battery temperature control system (if so equipped) or the air conditioning system operates while the vehicle is not in charging state.

Immediate charge

When the charging timer is not turned on, charging automatically starts when a normal charge connector is connected to the vehicle.

Use the immediate charge mode any time you need to start charging immediately while a charging timer is turned on.

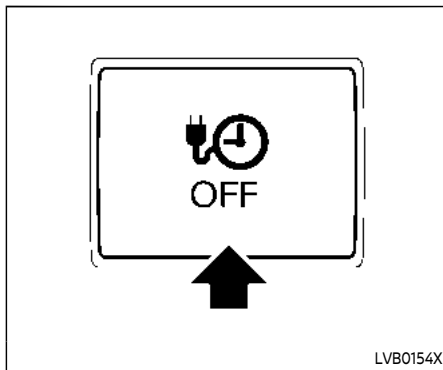

To perform the immediate charge:

1. Place the power switch in the OFF position and connect the normal charge connector to the charge port.
2. Push the immediate charge switch.

NOTE:

- **When the charging status indicator light (see "Charging status indicator light" (P.CH-38)) flashes in green after the charge connector is connected, the charge state is in the charging timer mode. You can push the immediate charge switch to start the immediate charge.**

- **When the immediate charge switch is pushed, the immediate charge mode is kept for 15 minutes even if you connect or disconnect the charge connector.**
- **To cancel the immediate charge mode, push the immediate charge switch while connecting the charge connector to the vehicle. The charge mode switches to charging timer and the vehicle will be in a charging standby state.**
However, even if you push the immediate charge switch once again, the immediate charge mode will not start and the charging timer mode will continue.

CHARGING RELATED REMOTE FUNCTION

This vehicle incorporates a communication device that is called a TCU (Telematics Communication Unit). The communication connection between this unit and the NISSAN Data Center allows for various remote function services.

• Remote battery status check:

The charging status of the Li-Ion battery can be checked using the NissanConnect® Services app (if so equipped), even if you are not in the vehicle.

- **Remote start charge:**

The function of starting the Li-ion battery charge or starting the heater and air conditioner is available using your internet enabled smart phone.

- **Plug-in reminder:**

A notification can be sent to your internet enabled smart phone if the plug is not connected at the specific time you selected, after turning off the power switch.

NOTE:

- **Enrolling in NissanConnect® Services is necessary before using this service.**
- **To check the Li-ion battery charging status using an internet enabled smart phone, the following conditions must be met:**
 - **The vehicle must be located in a cellular phone coverage area.**
 - **The cellular phone must be located in an area with cellular phone coverage.**
 - **Some cellular phones are not compatible and cannot be used to check the Li-ion battery charging status. Please confirm beforehand.**
- **Certain remote functions require a compatible smart phone, which is**

not included with the vehicle.

- **NissanConnect® Services information system features are included through a subscription service which requires owner consent to activate. The subscription must be active to use these features.**
- **NissanConnect® Services communications may be received at a verified e-mail address or via SMS/text message or push notification on compatible mobile phones.**
- **Standard text rates and/or data usage may apply depending on your carrier.**

CHARGING RELATED INDICATOR LIGHTS

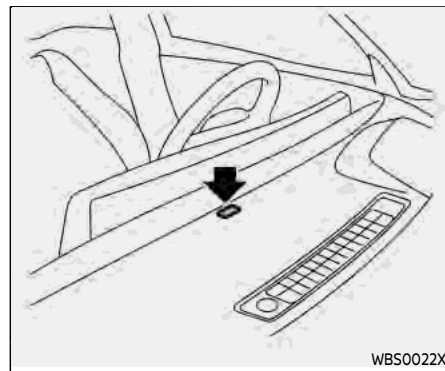

CHARGING STATUS INDICATOR LIGHT

The charging status indicator light primarily indicates the charging status, and is visible from both inside and outside the vehicle.

When the normal charge connector is connected incorrectly

The indicator light will flash in red and a beep will sound three times for 30 seconds when the charge connector is connected incorrectly to the normal charge port.

The charging cannot be performed in this condition.

Ready for charging timer

If the charging timer is set, the indicator light flashes in green. (The indicator light illuminates for approximately 2 seconds and will turn off for approximately 2 seconds, repeatedly.) The indicator light turns off after approximately 5 minutes.

When charging

When the Li-ion battery is being charged, the charging status indicator light flashes in blue and it will change the flashing speed depending on the amount the Li-ion battery is charged. As the lithium-ion battery charging improves, the indicator flashes slowly.

The amount the Li-ion battery is charged is also displayed by the Li-ion battery available charge gauge on the vehicle information display.

When fully charged

The indicator light illuminates in blue when the Li-ion battery is fully charged.

The indicator light turns off after approximately 5 minutes or when the charge connector is removed.

When the EV system automatically turns on

The indicator light flashes in green when the EV system automatically turns on. (The indicator light illuminates for ap-

proximately 1 second and will turn off for approximately 1 second, repeatedly.)

For example, the EV system will automatically turn on in the following situations:

- When 12-volt battery is charging.
- When the software is updating.
- When the air conditioning system, such as Climate Ctrl. Timer, remote climate control or Li-ion battery temperature control is working.
- When the plug of the EVSE is pulled off from the outlet.

The indicator light flashes in green as follows:

- Ready for charging timer: flashes every two seconds
- EV system on: flashes every one second

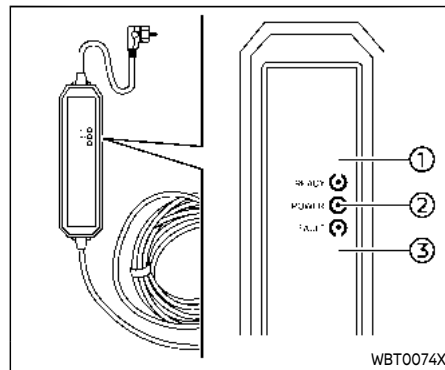

- ① READY: GREEN
- ② POWER: ORANGE
- ③ FAULT: RED

NISSAN EVSE (Electric Vehicle Supply Equipment) CONTROL BOX INDICATOR LIGHT (if so equipped)

When a normal or trickle charge is being performed using the NISSAN EVSE (Electric Vehicle Supply Equipment), the charging status as well as any EVSE malfunction can be checked with the indicator lights on the EVSE control box.

READY	POWER	FAULT	Status and action to be taken
●	●	●	All indicator lights will illuminate for a 0.5 second check when the EVSE is first connected to the outlet socket.
●	OFF	OFF	The EVSE is connected to the outlet socket. If the normal charge connector is connected to the vehicle normal charge port, charging is complete or the charging timer is set (refer to "Charging timer" (P.CH-35)).
●	●	OFF	The EVSE is charging the vehicle.
OFF	OFF	OFF	No power is detected by the EVSE from the outlet socket. Check the outlet supply breaker. If the outlet supply is OK and all the indicator lights do not illuminate for 0.5 seconds, the EVSE may be broken. Stop using the EVSE. It is recommended that you visit a NISSAN certified ARIYA dealer.
○	OFF	OFF	The EVSE could not detect sufficient outlet socket earth grounding for reliable EV charging. Consult a qualified electrician to have the outlet checked.
○	○	●	The temperature detection circuit in the domestic plug of the EVSE is malfunctioning. Indicator light status: Light OFF = Charge is stopped, Flashing = Charge current is reduced.
○	OFF	●	The EVSE is restricting the charging current. It is recommended that you contact a NISSAN certified ARIYA dealer.
○	○	○	The EVSE detected excessive heat in the domestic plug. Indicator light status: Light OFF = Charge is stopped, Flashing = Charge current is reduced.
○	OFF	○	The EVSE is restricting the charging current for safety. This may be caused by a malfunction in the outlet. Stop using the outlet and it is recommended that you contact a NISSAN certified ARIYA dealer. If the same indication continues after checking the outlet, it is recommended that you contact a NISSAN certified ARIYA dealer
●	○	●	The EVSE internal circuits malfunction. Stop use immediately it is recommended that you contact a NISSAN certified ARIYA dealer.
●	OFF	●	
●	OFF	○	The EVSE detected leakage current or PWM signal error. Stop using the EVSE immediately. It is recommended that you contact a NISSAN certified ARIYA dealer and check EVSE and vehicle.

Meaning	Light ON	Flashing	Light OFF
Symbol	●	○	OFF

CHARGING TROUBLESHOOTING GUIDE

Symptom	Possible cause	Possible solution
Charging cannot be performed.	The Li-ion battery is already fully charged.	Confirm the available Li-ion battery power remaining by checking Li-ion battery available charge gauge. If the gauge indicates full, the Li-ion battery is already fully charged and cannot be charged. Charging automatically turns off if the Li-ion battery is fully charged.
	The 12-volt battery is discharged.	The Li-ion battery cannot be charged if the vehicle electrical systems cannot be turned on. If the 12-volt battery is discharged, charge or jump start the 12-volt battery. See "Jump starting" (P.6-15).
	The vehicle has a malfunction.	The vehicle or charger may have a malfunction. Confirm if the warning light on the meter is illuminated. Confirm if the indicator on the charger is indicating a malfunction. If a warning is displayed, stop charging and consult a qualified electrician to have the outlet checked.
Normal or trickle charge cannot be performed.	There is no electrical power coming from the outlet.	Confirm that there has not been a power failure. Make sure the circuit breaker is active. If an electrical outlet or charging station with a timer device installed is used, power will only be available at the time set by the timer.
	The plug is not connected correctly.	Confirm the plug is connected correctly.
	There is no electrical power coming from the normal charging station.	Confirm operation procedure of the charging station.
	The charge connector is not connected correctly.	Confirm the charge connector is connected correctly.
	The EVSE or charging device may have a malfunction.	If Genuine NISSAN EVSE is used, see "Charging troubleshooting guide" (P.CH-41) for the device.
	The outlet (that the EVSE is connected to) is not connected to the power source correctly.	Confirm the condition according to the illumination pattern of the indicator light on the EVSE. For additional information, see "NISSAN EVSE (Electric Vehicle Supply Equipment) control box indicator light" (P.CH-39).
Immediate charge cannot be performed.	Charging timer has been set.	Push the immediate charge switch or turn off the charging timer. See "Charging methods" (P.CH-35).

Symptom	Possible cause	Possible solution
Timer charging cannot be performed.	The charge cable is not connected.	Connect the charge cable.
	The time on the clock is wrong.	The charging timer does not start charging based on the clock located on the vehicle information display. Adjust the time. (See "Clock" (P.2-28).) If the 12-volt battery is discharged or if the Li-ion battery is disconnected, the time setting must be updated.
	Charging timer has not been set.	Set the charging timer schedule. See "Charging timer" (P.CH-35).
	Charging does not start because the charging timer start time and end time are set and the current time is before the set start time.	Confirm when the charging timer time is set to start charging. Change the charging timer setting to the desired charge time or push the immediate charge switch. See "Charging methods" (P.CH-35).
	The immediate charge switch is pushed.	To cancel the immediate charge, push the immediate charge switch again while connecting the charge connector to the vehicle. The charge mode returns to a standby state.
Normal charge stops during charging.	There is no electrical power coming from the outlet.	There may have been an electrical power failure, or the circuit breaker may have failed. Charging will resume when the power source is reset.
	The charge cable has been disconnected.	Check that the charge cable has not been disconnected.
	Charging timer end time has been reached.	When the charging timer is set and the charge end time is reached, charging will be stopped, even if the Li-ion battery is not fully charged.
	The electrical power supply from the normal charging station was stopped.	Confirm operation procedure of the charging station.
Normal charge connector cannot be removed.	The charge connector lock is locked.	Unlock the charge connector lock. See "Unlock operation" (P.CH-34).
	The vehicle has a malfunction.	If the normal charge connector cannot be removed when the connector has been unlocked, follow the unlocking steps. See "If the charge connector cannot be unlocked" (P.CH-34).

Symptom	Possible cause	Possible solution
Quick charge cannot be performed.	The quick charge connector is not connected correctly.	Check that the charge connector is connected correctly and that it is locked.
	The self-diagnostic function of the quick charge device returns a negative result.	There is a possibility that the vehicle has a malfunction. Stop charging and it is recommended that you contact a NISSAN certified ARIYA dealer.
	The power switch of the quick charger is off.	Check the power switch of the quick charger.
Quick charge stops during charging.	Charging is stopped by the quick charge timer.	Charging will stop depending on the timer function setting of the quick charge device. If you need to charge the Li-ion battery more, start the charging procedure again.
	The power supply for the quick charger is off.	Check whether the power supply for the quick charger is off.
Quick charge connector cannot be removed.	The charge connector is locked.	If it is necessary to remove the charge connector before starting to charge, wait a minutes until the data communication between the vehicle and the quick charger is stopped.
	The vehicle has a malfunction.	If the quick charge connector cannot be removed when the connector has been unlocked, follow the unlocking steps. See "If the charge connector cannot be unlocked" (P.CH-34).

MEMO

CH-44 **Charging**

1 Safety – Seats, seat belts and supplemental restraint system

Seats	1-3	Child restraints	1-26
Front seats	1-4	Precautions on child restraints	1-26
Rear seats	1-7	Lower Anchors and Tethers for Children (LATCH) system	1-28
Armrest	1-9	Rear-facing child restraint installation using LATCH	1-32
Head restraints/headrests	1-10	Rear-facing child restraint installation using the seat belts	1-34
Adjustable head restraint/headrest components	1-11	Forward-facing child restraint installation using LATCH	1-37
Non-adjustable head restraint/headrest components	1-12	Forward-facing child restraint installation using the seat belts	1-40
Remove	1-12	Booster seats	1-44
Install	1-12	Supplemental Restraint System (SRS)	1-48
Adjust	1-13	Precautions on SRS	1-48
Seat belts	1-14	NISSAN Advanced Air Bag System (front seats)	1-54
Precautions on seat belt usage	1-14	Driver and front passenger supplemental knee air bag	1-63
Seat belt warning light and chime	1-17	Front, front central, rear outboard seat-mounted side-impact supplemental air bag and roof-mounted curtain side-impact and rollover supplemental air bag systems	1-65
Pregnant women	1-17	Seat belts with pretensioners (front and rear outboard seats)	1-67
Injured persons	1-17		
Center mark on seat belts	1-18		
Three-point type seat belt with retractor	1-18		
Seat belt extenders	1-22		
Seat belt maintenance	1-22		
Child safety	1-23		
Infants	1-24		
Small children	1-24		
Larger children	1-24		

Supplemental air bag warning labels 1-68
Supplemental air bag warning light 1-69

Repair and replacement procedure 1-69

SEATS

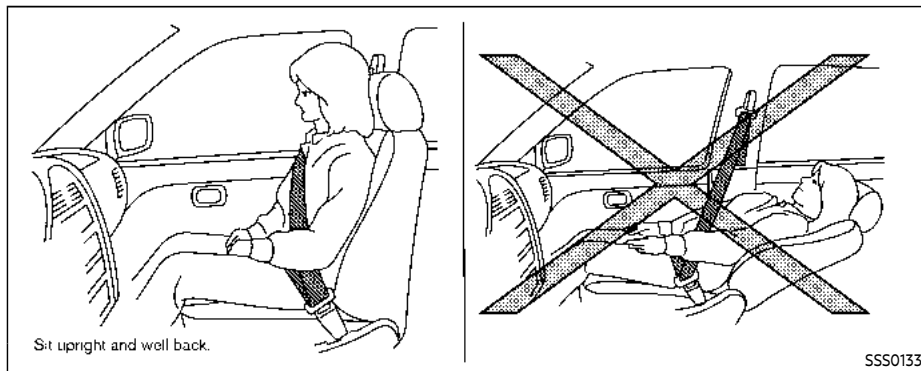

WARNING

- Do not ride in a moving vehicle when the seatback is reclined. This can be dangerous. The shoulder belt will not be against your body. In an accident, you could be thrown into it and receive neck or other serious injuries. You could also slide under the lap belt and receive serious internal injuries.
- For the most effective protection when the vehicle is in motion, the seat should be upright. Always sit

well back and upright in the seat with both feet on the floor and adjust the seat properly. See "Precautions on seat belt usage" (P.1-14).

- After adjustment, gently rock in the seat to make sure it is securely locked.
- Do not leave children unattended inside the vehicle. They could unknowingly activate switches or controls. Unattended children could become involved in serious accidents.

- To help avoid risk of injury or death through unintended operation of the vehicle and/or its systems, do not leave children, people who require the assistance of others or pets unattended in your vehicle. Additionally, the temperature inside a closed vehicle on a warm day can quickly become high enough to cause a significant risk of injury or death to people and pets.
- Do not adjust the driver's seat while driving so full attention may be given to vehicle operation. The seat may move suddenly and could cause loss of control of the vehicle.
- The seatback should not be reclined any more than needed for comfort. Seat belts are most effective when the passenger sits well back and straight up in the seat. If the seatback is reclined, the risk of sliding under the lap belt and being injured is increased.



CAUTION

When adjusting the seat positions, be sure not to contact any moving parts to avoid possible injuries and/or damage.

FRONT SEATS

Your vehicle seats can be adjusted in manual or power operation. For additional information about adjusting the seats, refer to the steps outlined in this section.

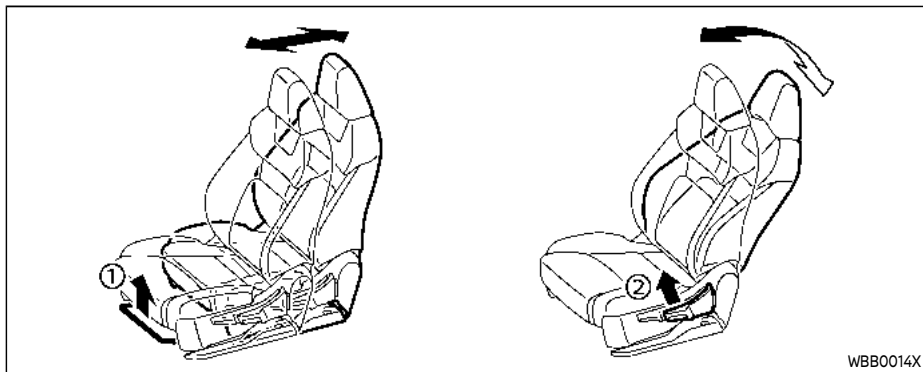

Front manual seat adjustment

Forward and backward:

1. Pull up the adjusting lever ①.
2. Slide the seat to the desired position.
3. Release the adjusting lever to lock the seat in position.

Reclining:

1. Pull up the adjusting lever ②.
2. Tilt the seatback to the desired position.
3. Release the adjusting lever to lock the seatback in position.

The reclining feature allows the adjustment of the seatback for occupants of

different sizes to help obtain the proper seat belt fit. (See "Seat belts" (P.1-14).)

The seatback may be reclined to allow occupants to rest when the vehicle is parked.

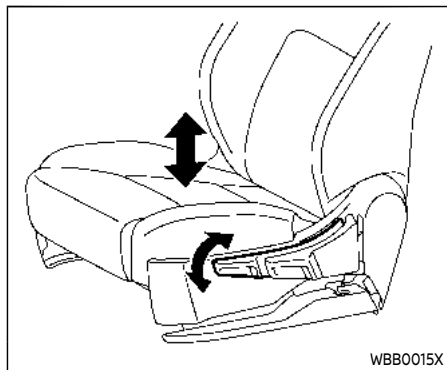

See "Memory seat" (P.3-41) for the seat position memory function (if so equipped).

Seat lifter:

Pull up or push down the adjusting lever to adjust the seat height until the desired position is achieved.

Front power seat adjustment

Operating tips:

- The power seat motor has an auto-reset overload protection circuit. If the motor stops during the seat adjustment, wait 30 seconds, then reactivate the switch.
- To avoid discharge of the battery, do not operate the power seats for a long period of time when the EV system is not running.

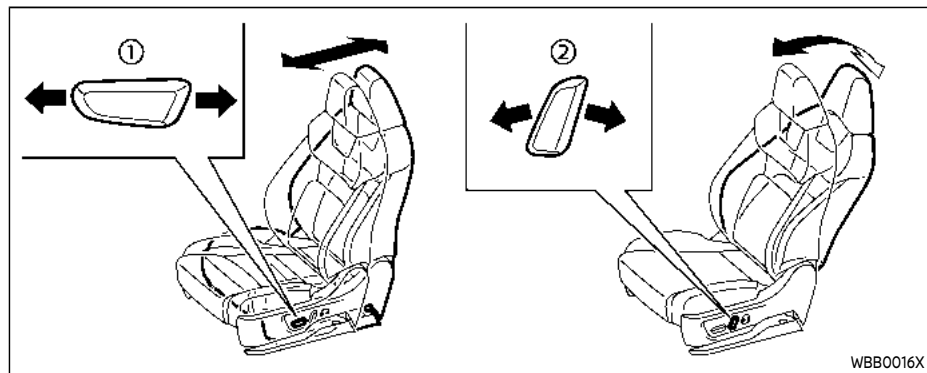

Forward and backward:

Move forward or backward the adjusting switch ① to the desired position.

Reclining:

Move forward or backward the adjusting switch ② to the desired position.

The reclining feature allows the adjustment of the seatback for occupants of different sizes to help obtain the proper seat belt fit. (See "Seat belts" (P.1-14).)

The seatback may be reclined to allow occupants to rest when the vehicle is parked.

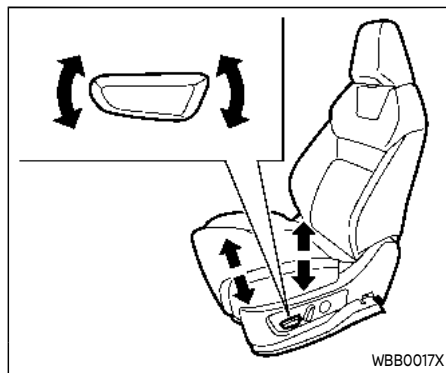

Seat lifter:

Move the switch as shown to adjust the angle of the front portion or height of the seat.

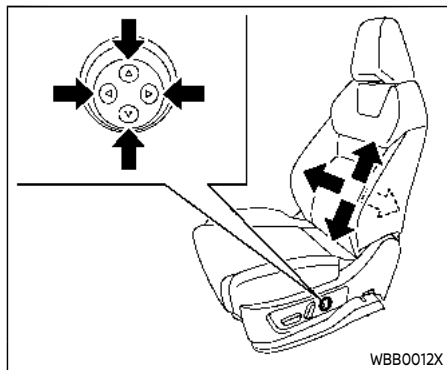

Lumbar support (if so equipped)

The lumbar support feature provides lower back support to the driver.

Push the switch as shown to adjust the seat lumbar area until the desired position is achieved.

NOTE:

An operating noise may be heard when the power switch is placed in the ON or OFF position to initialize the lumbar support. This is not a malfunction.

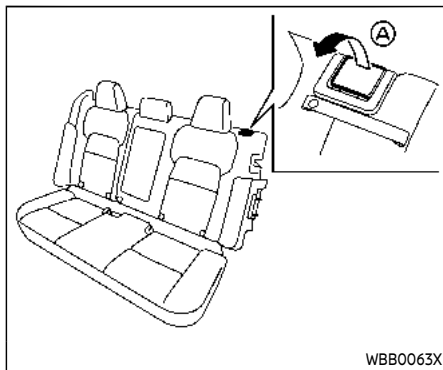

REAR SEATS

Reclining

1. Pull up the lever **A**.
2. Tilt the seatback backward. It is reclined slightly.
3. Release the lever to lock the seatback in position.

Folding

Before folding the rear seats

- Release the outer seat belt from the seat belt guide. (See "Unfastening the seat belts" (P.1-20).)
- Secure the outer seat belt on the seat belt hook. (See "Seat belt hook" (P.1-22).)
- If the rear seat is equipped with the head restraints/headrests, slide the front seat forward to make enough room behind the seat so that the rear seatback can be folded flat.
- Remove drink containers from the rear cup holder (if so equipped).

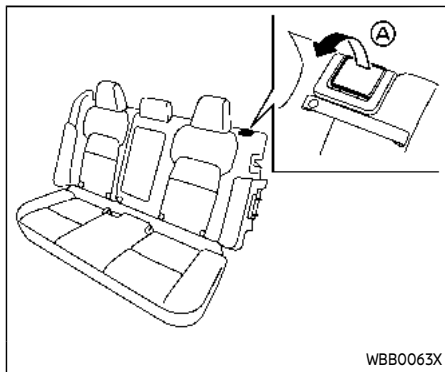

To fold down the seatback

- Pull up the lever **A** and fold the seatback flat.

To return the seatback

To return the seatback to a seating position, raise the seatback until it latches in place.

When returning the seatback, make sure that the seat belts are not interfering with the seatback latch mechanism.

WARNING

- Before folding up the rear seats, ensure the seat belts are not obstructing the rear seatback latches to avoid damage to the seat belt webbing.
- When returning the seatback, make sure that the seat belts are not interfering with the seatback latch mechanism.
- Never allow anyone to ride in the cargo area or on the rear seats when they are in the fold-down position. In a collision, people riding in these areas without proper restraints are more likely to be seriously injured or killed.
- Do not allow people to ride in any area of your vehicle that is not equipped with seats and seat belts. Be sure everyone in your vehicle is in a seat and using a seat belt properly.
- Do not allow more than one person to use the same seat belt.
- Do not fold down the rear seats when occupants are in the rear seat area or any luggage is on the rear seats.

– Make sure that the seat path is clear before moving the seat.

– Be careful not to allow hands or feet to get caught or pinched in the seat.

- Head restraints/headrests should be adjusted properly as they may provide significant protection against injury in an accident. Always replace and adjust them properly if they have been removed for any reason.
- If the head restraints/headrests are removed for any reason, they should be securely stored to prevent them from causing injury to passengers or damage to the vehicle in case of sudden braking or an accident.
- When returning the seatbacks to the upright position, be certain they are completely secured in the latched position. If they are not completely secured, passengers may be injured in an accident or sudden stop.
- Properly secure all cargo to help prevent it from sliding or shifting. Do not place cargo higher than the seatbacks. In a sudden stop

or collision, unsecured cargo could cause personal injury.

WARNING

- After adjustment, gently rock in the seat to make sure it is securely locked.
- Do not ride in a moving vehicle when the seatback is reclined. This can be dangerous. The shoulder belt will not be against your body. In an accident, you could be thrown into it and receive neck or other serious injuries. You could also slide under the lap belt and receive serious internal injuries.
- For the most effective protection when the vehicle is in motion, the seat should be upright. Always sit well back and upright in the seat with both feet on the floor and adjust the seat belt properly. (See "Precautions on seat belt usage" (P.1-14).)



CAUTION

Do not fold or return the seatback using the seat belt guide. Doing so may cause damage to the seat belt guide.

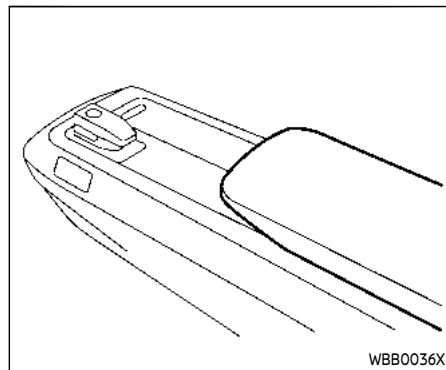

ARMREST

Front seats

The console box lid can be used as an armrest.

Power sliding function (if so equipped)

The position of the center console with front armrest can be adjusted to your desired position.

See "Console box" (P.2-85).

Rear seat (if so equipped)

The center seatback can be folded to make the armrest.

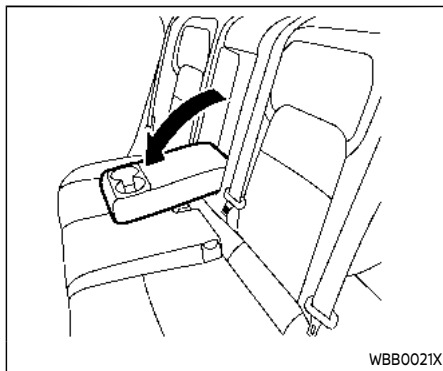

Fold down the seatback until it is horizontal.

HEAD RESTRAINTS/HEADRESTS



WARNING

Head restraint/headrest supplement the other vehicle safety systems. They may provide additional protection against injury in certain rear end collisions. Adjustable head restraints/headrests must be adjusted properly, as specified in this section. Check the adjustment after someone else uses the seat. Do not attach anything to the head restraint/headrest stalks or remove the head restraint/headrest. Do not use the seat if the head restraint/headrest has been removed. If the head restraint/headrest was removed, reinstall and properly adjust the head restraint/headrest before an occupant uses the seating position. Failure to follow these instructions can reduce the effectiveness of the head restraint/headrest. This may increase the risk of serious injury or death in a collision.

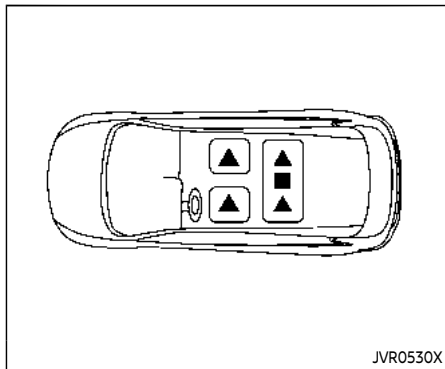

The illustration shows the seating positions equipped with head restraint/headrest.

▲ Indicates the seating position is equipped with a head restraint.

■ Indicates the seating position is equipped with a headrest.

+ Indicates the seating position is not equipped with a head restraint or headrest.

- Your vehicle is equipped with a head restraint/headrest that may be integrated, adjustable or non-adjustable.
- Adjustable head restraints/headrests have multiple notches along the stalk to lock them in a desired adjustment

position.

- The non-adjustable head restraints/headrests have a single locking notch to secure them to the seat frame.
- Proper Adjustment:
 - For the adjustable type, align the head restraint/headrest so the center of your ear is approximately level with the center of the head restraint/headrest.
 - If your ear position is still higher than the recommended alignment, place the head restraint/headrest at the highest position.
- If the head restraint/headrest has been removed, ensure that it is re-installed and locked in place before riding in that designated seating position.

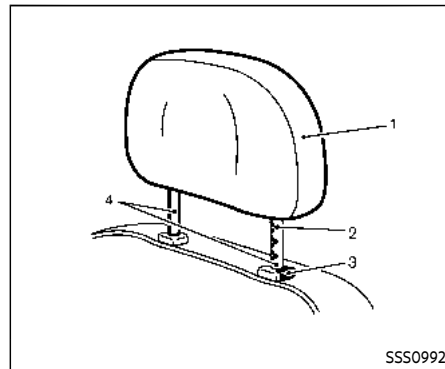

ADJUSTABLE HEAD RESTRAINT/ HEADREST COMPONENTS

1. Removable head restraint/headrest
2. Multiple notches
3. Lock knob
4. Stalks

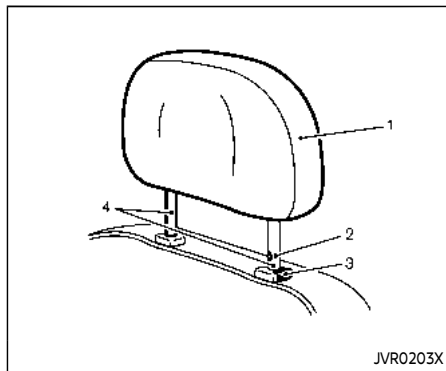

NON-ADJUSTABLE HEAD RESTRAINT/HEADREST COMPONENTS

1. Removable head restraint/headrest
2. Single notch
3. Lock knob
4. Stalks

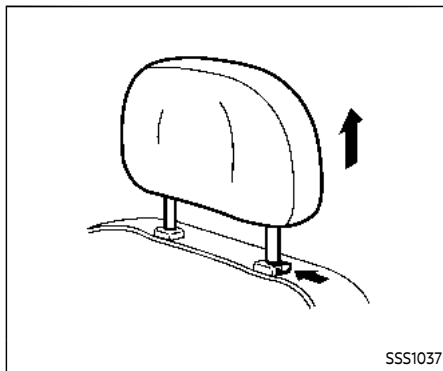

REMOVE

Use the following procedure to remove the head restraint/headrest.

1. Pull the head restraint/headrest up to the highest position.
2. Push and hold the lock knob.
3. Remove the head restraint/headrest from the seat.
4. Store the head restraint/headrest properly in a secure place so it is not loose in the vehicle.
5. Reinstall and properly adjust the head restraint/headrest before an occupant uses the seating position.

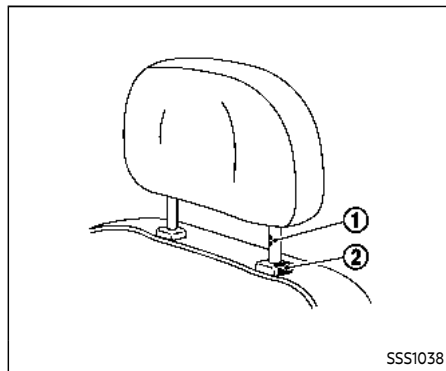

INSTALL

1. Align the head restraint/headrest stalks with the holes in the seat. Make sure that the head restraint/headrest is facing the correct direction. The stalk with the adjustment notch ① must be installed in the hole with the lock knob ②.
2. Push and hold the lock knob and push the head restraint/headrest down.
3. Properly adjust the head restraint/headrest before an occupant uses the seating position.

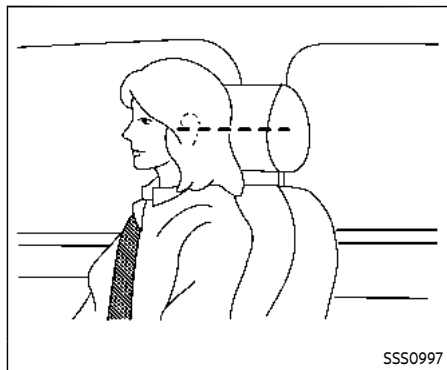

ADJUST

For adjustable head restraint/headrest

Adjust the head restraint/headrest so the center is level with the center of your ears. If your ear position is still higher than the recommended alignment, place the head restraint/headrest at the highest position.

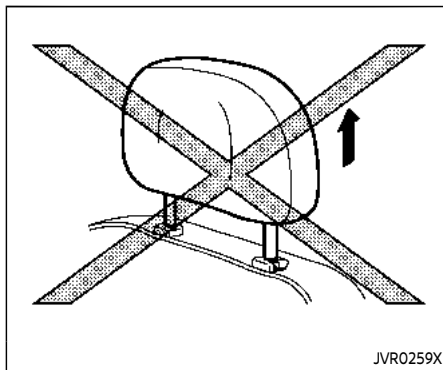

For non-adjustable head restraint/headrest

Make sure the head restraint/headrest is positioned so the lock knob is engaged in the notch before riding in that designated seating position.

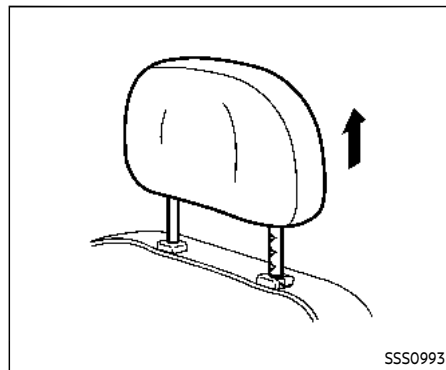

Raise

To raise the head restraint/headrest, pull it up.

Make sure the head restraint/headrest is positioned so the lock knob is engaged in the notch before riding in that designated seating position.

SEAT BELTS

PRECAUTIONS ON SEAT BELT USAGE

If you are wearing your seat belt properly adjusted, and you are sitting upright and well back in your seat with both feet on the floor, your chances of being injured or killed in an accident and/or the severity of injury may be greatly reduced. NISSAN strongly encourages you and all of your passengers to buckle up every time you drive, even if your seating position includes a supplemental air bag.

Most U.S. states and Canadian provinces or territories specify that seat belts be worn at all times when a vehicle is being driven.

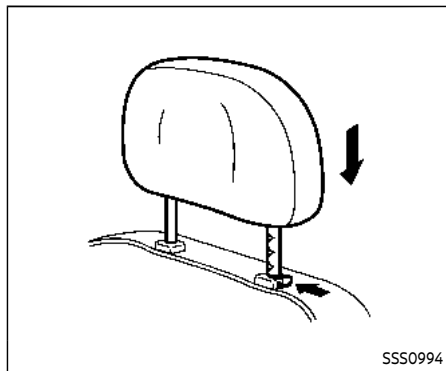

Lower

To lower, push and hold the lock knob and push the head restraint/headrest down.

Make sure the head restraint/headrest is positioned so the lock knob is engaged in the notch before riding in that designated seating position.

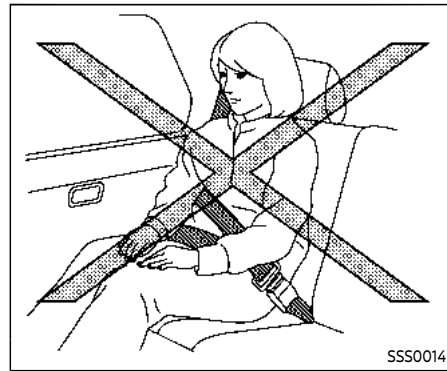
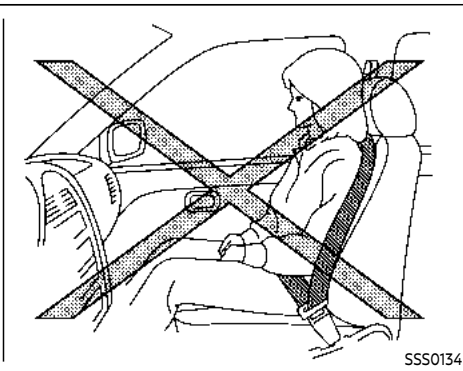
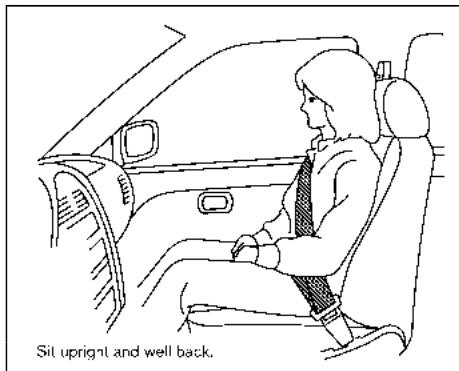
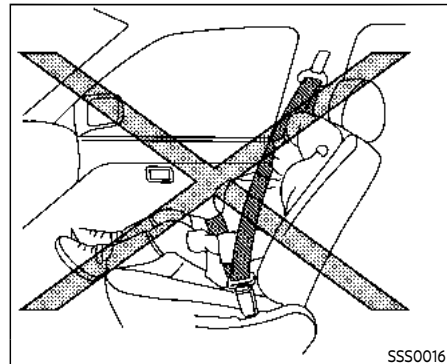
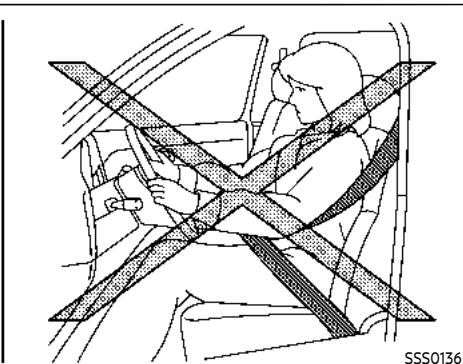
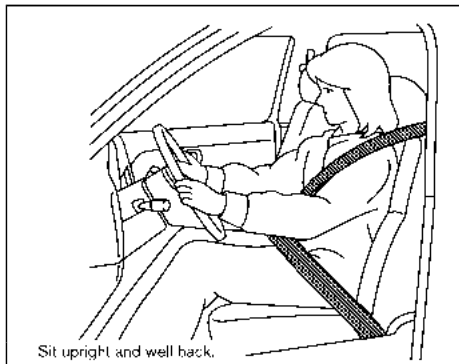



WARNING

- Every person who drives or rides in this vehicle should use a seat belt at all times. Children should be properly restrained in the rear seat and, if appropriate, in a child restraint.
- The seat belt should be properly adjusted to a snug fit. Failure to do so may reduce the effectiveness of the entire restraint system and increase the chance or severity of injury in an accident. Serious injury or death can occur if the seat belt is not worn properly.
- Always route the shoulder belt over your shoulder and across your chest. Never put the belt behind your back, under your arm or across your neck. The belt should be away from your face and neck, but not falling off your shoulder.
- Position the lap belt as low and snug as possible **AROUND THE HIPS, NOT THE WAIST**. A lap belt worn too high could increase the risk of internal injuries in an accident.

- Be sure the seat belt tongue is securely fastened to the proper buckle.
- Do not wear the seat belt inside out or twisted. Doing so may reduce its effectiveness.
- Do not allow more than one person to use the same seat belt.
- Never carry more people in the vehicle than there are seat belts.
- If the seat belt warning light glows continuously while the power switch is ON with all doors closed and all seat belts fastened, it may indicate a malfunction in the system. Have the system checked. It is recommended you visit a NISSAN certified ARIYA dealer for this service.
- No changes should be made to the seat belt system. For example, do not modify the seat belt, add material, or install devices that may change the seat belt routing or tension. Doing so may affect the operation of the seat belt system. Modifying or tampering with the seat belt system may result in serious personal injury.

- Once a seat belt pretensioner has activated, it cannot be reused and must be replaced together with the retractor. It is recommended you visit a NISSAN certified ARIYA dealer for this service.
- All seat belt assemblies, including retractors and attaching hardware, should be inspected after any collision. It is recommended you visit a NISSAN certified ARIYA dealer for this service. NISSAN recommends that all seat belt assemblies in use during a collision be replaced unless the collision was minor and the belts show no damage and continue to operate properly. Seat belt assemblies not in use during a collision should also be inspected and replaced if either damage or improper operation is noted.
- All child restraints and attaching hardware should be inspected after any collision. Always follow the restraint manufacturer's inspection instructions and replacement recommendations. The child restraints should be replaced if they are damaged.



SEAT BELT WARNING LIGHT AND CHIME

The driver and front passenger seats are equipped with an enhanced seat belt reminder function. If your vehicle is equipped with an enhanced seat belt reminder function, a visual and audible alert will operate if a driver or front passenger seat belt is unbuckled at speeds of approximately 10 MPH (15 km/h) or more under the following conditions:

- If the driver seat belt is not fastened.
- The front passenger's seat belt is not fastened and the seat is occupied by a passenger for 7 seconds after the

power switch is placed in the ON position.

- The front passenger's seat belt is not fastened and objects or external force on the passenger seat change the seat belt reminder classification to "occupied".

The seat belt warning light will flash under the conditions shown above until the necessary seat belt is securely fastened.

A warning chime will sound for approximately 95 seconds or until one of the following conditions is met:

- The unbuckled front passenger's seat belt is securely fastened.
- The seat belt reminder function in the front passenger seat no longer detects that the front passenger seat is occupied.
- The power switch is turned off.

The below situations could result in the seat belt warning light being illuminated and the chime sounding, even with no occupant present in the passenger seat:

- Heavy objects placed on the seat.
- Someone pushing or pulling on the front passenger seat.
- An object placed under the front passenger seat.

- An object placed between the seat cushion and center console or between the seat cushion and the door.
- An object hanging on the seat or placed in the seatback pocket.
- A child restraint or other object pressing against the rear of the seatback.

The rear seats may be equipped with a seat belt warning in the vehicle information display. (See "10. Rear seat belt warning" (P.2-35).)

PREGNANT WOMEN

NISSAN recommends that pregnant women use seat belts. The seat belt should be worn snug, and always position the lap belt as low as possible around the hips, not the waist. Place the shoulder belt over your shoulder and across your chest. Never put the lap/shoulder belt over your abdominal area. Contact your doctor for specific recommendations.

INJURED PERSONS

NISSAN recommends that injured persons use seat belts, depending on the injury. Check with your doctor for specific recommendations.

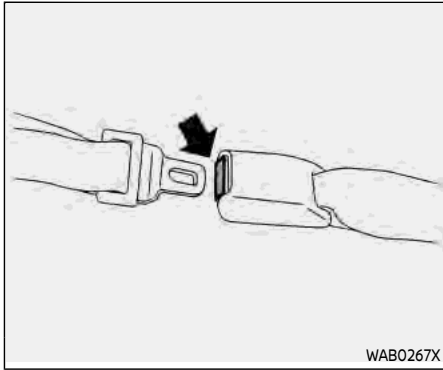

CENTER MARK ON SEAT BELTS

Selecting correct set of seat belts

The center seat belt buckle is identified by the CENTER mark. The center seat belt tongue can be fastened only into the center seat belt buckle.

THREE-POINT TYPE SEAT BELT WITH RETRACTOR

WARNING

- Every person who drives or rides in this vehicle should use a seat belt at all times. Children should be in the rear seats and in an appropriate restraint.
- Do not ride in a moving vehicle when the seatback is reclined. This can be dangerous. The shoulder belt will not be against your body. In an accident, you could be thrown into it and receive neck or other serious injuries. You could also slide under the lap belt and receive serious internal injuries.
- For the most effective protection when the vehicle is in motion, the seat should be upright. Always sit well back and upright in the seat with both feet on the floor and adjust the seat belt properly.
- Do not allow children to play with the seat belts. Most seating positions are equipped with Automatic Locking Retractor (ALR) mode seat belts. If the seat belt

becomes wrapped around a child's neck with the ALR mode activated, the child can be seriously injured or killed if the seat belt retracts and becomes tight. This can occur even if the vehicle is parked. Unbuckle the seat belt to release the child. If the seat belt can not be unbuckled or is already unbuckled, release the child by cutting the seat belt with a suitable tool (such as a knife or scissors) to release the seat belt.

Fastening the seat belts

1. Adjust the seat. (See "Seats" (P.1-3).)



JVR0572X

2. Slowly pull the seat belt out of the retractor and insert the tongue into the buckle (A) until you hear and feel the latch engage.
 - **The retractor is designed to lock during a sudden stop or on impact. A slow pulling motion permits the belt to move and allows you some freedom of movement in the seat.**
 - **If the seat belt cannot be pulled from its fully retracted position, firmly pull the belt and release it. Then smoothly pull the belt out of the retractor.**

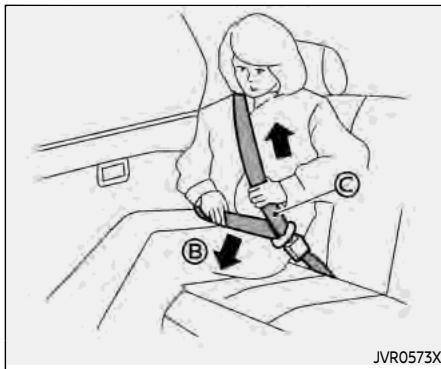

JVR0573X

3. Position the lap belt portion **low and snug on the hips** (B) as shown.
4. Pull the shoulder belt portion toward the retractor to take up extra slack (C). Be sure the shoulder belt is routed over your shoulder and across your chest.

The three-point seat belts in the front passenger seat and the rear seating positions have two modes of operation:

- Emergency Locking Retractor (ELR)
 - Automatic Locking Retractor (ALR)
- The Emergency Locking Retractor (ELR) mode allows the seat belt to extend and retract to allow the driver and passengers some freedom of movement in the seat.

The ELR locks the seat belt when the vehicle slows down rapidly or during certain impacts.

The Automatic Locking Retractor (ALR) mode (child restraint mode) locks the seat belt for child restraint installation.

When ALR mode is activated the seat belt cannot be extended again until the seat belt tongue is detached from the buckle and fully retracted. The seat belt returns to the ELR mode after the seat belt fully retracts. For additional information, see "Child restraints" (P.1-26).

The ALR mode should be used only for child restraint installation. During normal seat belt use by an occupant, the ALR mode should not be activated. If it is activated, it may cause uncomfortable seat belt tension. It can also change the operation of the front passenger air bag.



WARNING

When fastening the seat belts, be certain that seatbacks are completely secured in the latched position. If they are not completely secured, passengers may be injured in an accident or sudden stop.

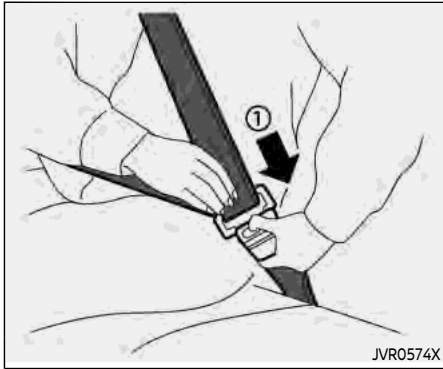

Unfastening the seat belts

To unfasten the seat belt, push the button on the buckle ①. The seat belt automatically retracts.

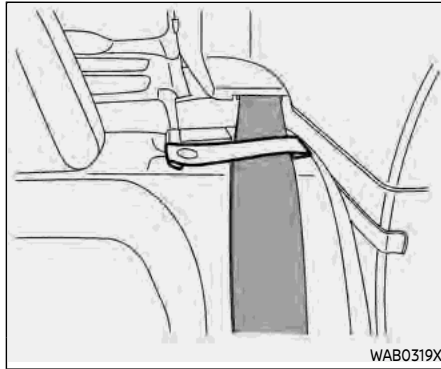

Seat belt guide (for rear seat):

When the seat belt guide is used on the rear seat, the seat belt can easily be pulled out. Do not allow the seat belt to twist.

When the seat belt is released from the seat belt guide, use the seat belt guide when fastening the seat belt again.



WARNING

When using the seat belt guide, make sure that the seat belt guide is securely installed to the seat. Otherwise, the seat belt may slip

and could cause personal injury.



CAUTION

- When loading or unloading a cargo with the seatback folded down, always release the seat belt from the seat belt guide. Otherwise, the seat belt guide may be damaged.
- Do not adjust, fold or unfold the seatback by holding the seat belt guide. Doing so may damage the seat belt guide.

Checking seat belt operation

Seat belt retractors are designed to lock seat belt movement by two separate methods:

- When the belt is pulled quickly from the retractor.
 - When the vehicle slows down rapidly.
- To increase your confidence in the seat belts, check the operation as follows:
- Grasp the shoulder belt and pull forward quickly. The retractor should lock and restrict further belt movement.

If the retractor does not lock during this check, get the system checked. It is recommended you visit a NISSAN certified ARIYA dealer for this service, or to learn more about seat belt operation.

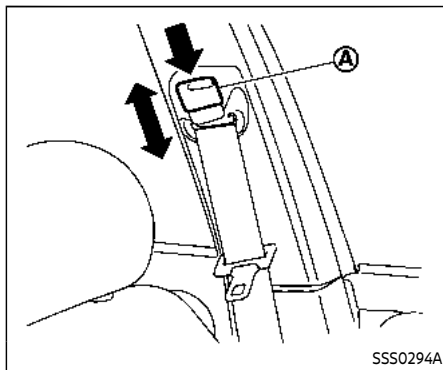

Shoulder belt height adjustment (for front seats)

The shoulder belt anchor height should be adjusted to the position best for you. (See "Precautions on seat belt usage" (P.1-14).)

To adjust, push down the adjustment button (A), and then move the shoulder belt anchor to the desired position, so that the belt passes over the center of the shoulder. The belt should be away from your face and neck, but not falling off of your shoulder. Release the adjustment button to lock the shoulder belt anchor into position.

The range of height adjustment of the

shoulder belt may vary depending on the model.



WARNING

- After adjustment, release the adjustment button and try to move the shoulder belt anchor up and down to make sure it is securely fixed in position.
- The shoulder belt anchor height should be adjusted to the position best for you. Failure to do so may reduce the effectiveness of the entire restraint system and increase the chance or severity of injury in an accident.

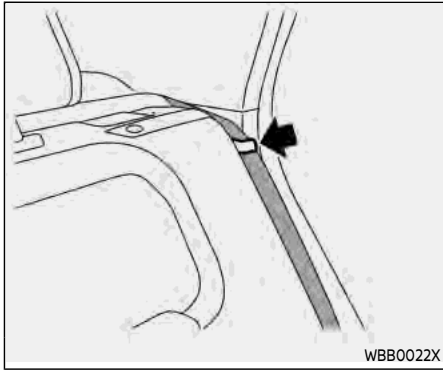

Seat belt hook

When the seat belt is not in use and when folding down the rear seats, hook the rear outer seat belts on the seat belt hooks.

Release the seat belt from the seat belt guide before putting it on the hook.

After returning the seat to a seating position, pass the seat belt through the seat belt guide again.

WARNING

- **Before folding up the rear seats, ensure the seat belts are not obstructing the rear seatback**

latches to avoid damage to the seat belt webbing.

- **Make sure the seat belts are not routed behind the seat when they are folded up by putting the belts back into the seat belt guide.**

SEAT BELT EXTENDERS

If, because of body size or driving position, it is not possible to properly fit the lap/shoulder belt and fasten it, an extender that is compatible with the installed seat belts is available that can be purchased. The extender adds approximately 8 in (200 mm) of length and may be used for either the driver or front passenger seating position. It is recommended you visit a NISSAN certified ARIYA dealer for assistance with purchasing an extender if an extender is required.

WARNING

- **It is recommended that only NISSAN seat belt extenders, made by the same company which made the original equipment seat belts, be used with NISSAN seat belts.**

- **Adults and children who can use the standard seat belt should not use an extender. Such unnecessary use could result in serious personal injury in the event of an accident.**

- **Never use seat belt extenders to install child restraints. If the child restraint is not secured properly, the child could be seriously injured or killed in a collision or a sudden stop.**

SEAT BELT MAINTENANCE

- **To clean the seat belt webbing**, apply a mild soap solution or any solution recommended for cleaning upholstery or carpets. Then wipe with a cloth and allow the seat belts to dry in the shade. Do not allow the seat belts to retract until they are completely dry.
- **If dirt builds up in the shoulder belt guide** of the seat belt anchors, the seat belts may retract slowly. Wipe the shoulder belt guide with a clean, dry cloth.
- **Periodically check to see that the seat belt and the metal components**, such as buckles, tongues, retractors, flexible wires and anchors, work properly. If loose parts, deterioration, cuts

or other damage on the webbing is found, the entire seat belt assembly should be replaced.

CHILD SAFETY



WARNING

Do not allow children to play with the seat belts. Most seating positions are equipped with Automatic Locking Retractor (ALR) mode seat belts. If the seat belt becomes wrapped around a child's neck with the ALR mode activated, the child can be seriously injured or killed if the seat belt retracts and becomes tight. This can occur even if the vehicle is parked. Unbuckle the seat belt to release the child. If the seat belt can not be unbuckled or is already unbuckled, release the child by cutting the seat belt with a suitable tool (such as a knife or scissors) to release the seat belt.

Children need adults to help protect them.

They need to be properly restrained.

In addition to the general information in this manual, child safety information is available from many other sources, including doctors, teachers, government traffic safety offices, and community organizations. Every child is different, so be sure to learn the best way to transport your child.

There are three basic types of child restraint systems:

- Rear-facing child restraint
- Forward-facing child restraint
- Booster seat

The proper restraint depends on the child's size. Generally, infants up to about 1 year and less than 20 lbs (9 kg) should be placed in rear-facing child restraints. Forward-facing child restraints are available for children who outgrow rear-facing child restraints and are at least 1 year old. Booster seats are used to help position a vehicle lap/shoulder belt on a child who can no longer use a forward-facing child restraint.



WARNING

Infants and children need special protection. The vehicle's seat belts may not fit them properly. The shoulder belt may come too close to the face or neck. The lap belt may not fit over their small hip bones. In an accident, an improperly fitting seat belt could cause serious or fatal injury. Always use appropriate child restraints.

All U.S. states and Canadian provinces or

territories require the use of approved child restraints for infants and small children. See “Child restraints” (P.1-26).

A child restraint may be secured in the vehicle by using either the LATCH (Lower Anchors and Tethers for Children) system or with the vehicle seat belt. See “Child restraints” (P.1-26) for more information.

NISSAN recommends that all pre-teens and children be restrained in the rear seat. Studies show that children are safer when properly restrained in the rear seat than in the front seat.

This is especially important because your vehicle has a supplemental restraint system (Air bag system) for the front passenger. See “Supplemental Restraint System (SRS)” (P.1-48).

INFANTS

Infants up to at least 1 year old should be placed in a rear-facing child restraint. NISSAN recommends that infants be placed in child restraints that comply with Federal Motor Vehicle Safety Standards or Canadian Motor Vehicle Safety Standards. You should choose a child restraint that fits your vehicle and always follow the manufacturer’s instructions for installation and use.

SMALL CHILDREN

Children that are over 1 year old and weigh at least 20 lbs (9 kg) should remain in a rear-facing child restraint as long as possible up to the height or weight limit of the child restraint. Children who outgrow the height or weight limit of the rear-facing child restraint and are at least 1 year old should be secured in a forward-facing child restraint with a harness. Refer to the manufacturer’s instructions for minimum and maximum weight and height recommendations. NISSAN recommends that small children be placed in child restraints that comply with Federal Motor Vehicle Safety Standards or Canadian Motor Vehicle Safety Standards. You should choose a child restraint that fits your vehicle and always follow the manufacturer’s instructions for installation and use.

LARGER CHILDREN

Children should remain in a forward-facing child restraint with a harness until they reach the maximum height or weight limit allowed by the child restraint manufacturer.

Once a child outgrows the height or weight limit of the harness-equipped forward-facing child restraint, NISSAN recommends that the child be placed in a commercially available booster seat to

obtain proper seat belt fit. For a seat belt to fit properly, the booster seat should raise the child so that the shoulder belt is properly positioned across the chest and the top, middle portion of the shoulder. The shoulder belt should not cross the neck or face and should not fall off the shoulder. The lap belt should lie snugly across the lower hips or upper thighs, not the abdomen.

A booster seat can only be used in seating positions that have a three-point type seat belt. The booster seat should fit the vehicle seat and have a label certifying that it complies with Federal Motor Vehicle Safety Standards or Canadian Motor Vehicle Safety Standards.

A booster seat should be used until the child can pass the seat belt fit test below:

- Are the child’s back and hips against the vehicle seatback?
- Is the child able to sit without slouching?
- Do the child’s knees bend easily over the front edge of the seat with feet flat on the floor?
- Can the child safely wear the seat belt (lap belt low and snug across the hips and shoulder belt across mid-chest and shoulder)?

- Is the child able to use the properly adjusted head restraint/headrest?
- Will the child be able to stay in position for the entire ride?

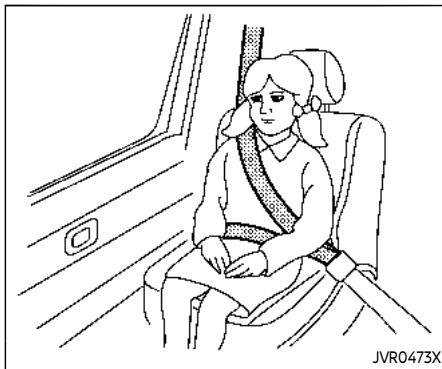

If you answered no to any of these questions, the child should remain in a booster seat using a three-point type seat belt.

NOTE:

Laws in some communities may follow different guidelines. Check local and state regulations to confirm your child is using the correct restraint system before traveling.



WARNING

Never let a child stand or kneel on any seat and do not allow a child in the cargo area. The child could be seriously injured or killed in a sudden stop or collision.

CHILD RESTRAINTS

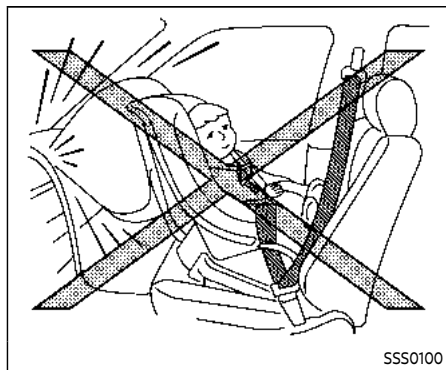
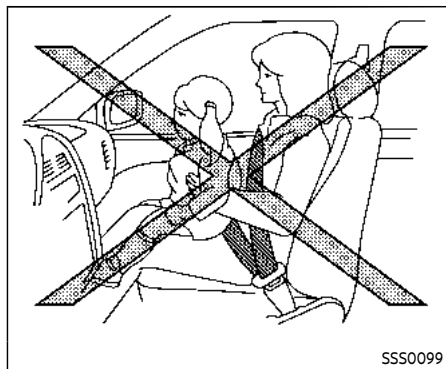

PRECAUTIONS ON CHILD RESTRAINTS

WARNING

- Failure to follow the warnings and instructions for proper use and installation of child restraints could result in serious injury or death of a child or other passengers in a sudden stop or collision:
 - The child restraint must be used and installed properly. Always follow all of the child restraint manufacturer's instructions for installation and use.
 - Infants and children should never be held on anyone's lap. Even the strongest adult cannot resist the forces of a collision.
 - Do not put a seat belt around both a child and another passenger.
 - NISSAN recommends that all child restraints be installed in the rear seat. Studies show that children are safer when properly restrained in the rear
- seat than in the front seat. If you must install a forward-facing child restraint in the front seat, see "Forward-facing child restraint installation using the seat belts" (P.1-40).
- Even with the NISSAN Advanced Air Bag System, never install a rear-facing child restraint in the front seat. An inflating air bag could seriously injure or kill a child. A rear-facing child restraint must only be used in the rear seat.
- Be sure to purchase a child restraint that will fit the child and vehicle. Some child restraints may not fit properly in your vehicle.
- Child restraint anchorages are designed to withstand only those loads imposed by correctly fitted child restraints. Under no circumstances are they to be used to attach adult seat belts, or other items or equipment to the vehicle. Doing so could damage the child restraint anchorages. The child restraint

will not be properly installed using the damaged anchorage, and a child could be seriously injured or killed in a collision.

- Never use the anchor points for adult seat belts or harnesses.
- A child restraint with a top tether strap should not be used in the front passenger seat.
- Keep seatbacks as upright as possible after fitting the child restraint.
- Infants and children should always be placed in an appropriate child restraint while in the vehicle.
- When the child restraint is not in use, keep it secured with the LATCH system or a seat belt. In a sudden stop or collision, loose objects can injure occupants or damage the vehicle.



CAUTION

A child restraint in a closed vehicle can become very hot. Check the seating surface and buckles before placing a child in the child restraint.

This vehicle is equipped with a universal child restraint anchor system, referred to as the LATCH (Lower Anchors and Tethers for CHildren) system. Some child restraints include rigid or webbing-mounted attachments that can be connected to these anchors.

For details, see “Lower Anchors and Tethers for CHildren (LATCH) system” (P.1-28).

If you do not have a LATCH compatible child restraint, the vehicle seat belts can be used.

Several manufacturers offer child restraints for infants and small children of various sizes. When selecting any child restraint, keep the following points in mind:

- Choose only a restraint with a label certifying that it complies with Federal Motor Vehicle Safety Standard 213 or Canadian Motor Vehicle Safety Standard 213.

- Check the child restraint in your vehicle to be sure it is compatible with the vehicle’s seat and seat belt system.
- If the child restraint is compatible with your vehicle, place your child in the child restraint and check the various adjustments to be sure the child restraint is compatible with your child. Choose a child restraint that is designed for your child’s height and weight. Always follow all recommended procedures.
- If the combined weight of the child and child restraint is less than 65 lbs (29.5 kg), you may use either the LATCH anchors or the seat belt to install the child restraint (not both at the same time).
- If the combined weight of the child and child restraint is greater than 65 lbs (29.5 kg), use the vehicle’s seat belt (not the lower anchors) to install the child restraint.
- Be sure to follow the child restraint manufacturer’s instructions for installation.

All U.S. states and Canadian provinces or territories require that infants and small children be restrained in an approved child restraint at all times while the vehicle is being operated. Canadian

law requires the top tether strap on forward-facing child restraints be secured to the designated anchor point on the vehicle.

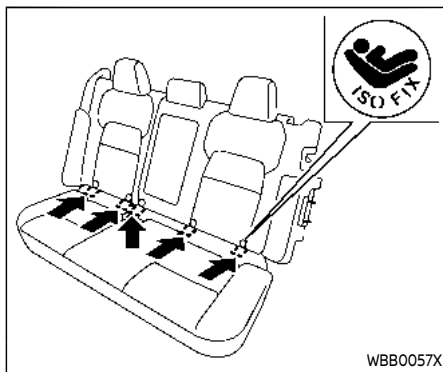

LATCH system anchor location

Lower Anchors and Tethers for Children (LATCH) SYSTEM

Your vehicle is equipped with special anchor points that are used with LATCH system compatible child restraints. This system may also be referred to as the ISOFIX or ISOFIX compatible system. With this system, you do not have to use a vehicle seat belt to secure the child restraint unless the combined weight of the child and child restraint exceeds 65 lbs (29.5 kg). If the combined weight of the child and child restraint is greater than 65 lbs (29.5 kg), use the vehicle's seat belt (not the lower anchors) to install the child restraint. Be sure to follow the child

restraint manufacturer's instructions for installation.

The LATCH anchor points can be used to install child restraints in the rear outboard seating positions.

LATCH lower anchor



WARNING

Failure to follow the warnings and instructions for proper use and installation of child restraints could result in serious injury or death of a child or other passengers in a sudden stop or collision:

- Only attach LATCH system compatible child restraints to the Lower Anchors shown in the illustration. For additional information, refer to the following sections of this Owner's Manual for installation guidance.
- Attach LATCH system compatible child restraints only at the locations shown in the illustration.
- Inspect the lower anchors by inserting your fingers into the lower anchor area. Feel to make sure there are no obstructions over the anchors such as seat belt

webbing or seat cushion material. The child restraint will not be secured properly if the lower anchors are obstructed.

- Child restraint anchorages are designed to withstand only those loads imposed by correctly fitted child restraints. Under no circumstances are they to be used to attach adult seat belts, or other items or equipment to the vehicle. Doing so could damage the child restraint anchorages. The child restraint will not be properly installed using the damaged anchorage, and a child could be seriously injured or killed in a collision.

LATCH lower anchor location

The LATCH lower anchor points are provided to install child restraints in the rear seats. **Do not attempt to install child restraints in the center and left outboard seating positions simultaneously using the LATCH lower anchors.**

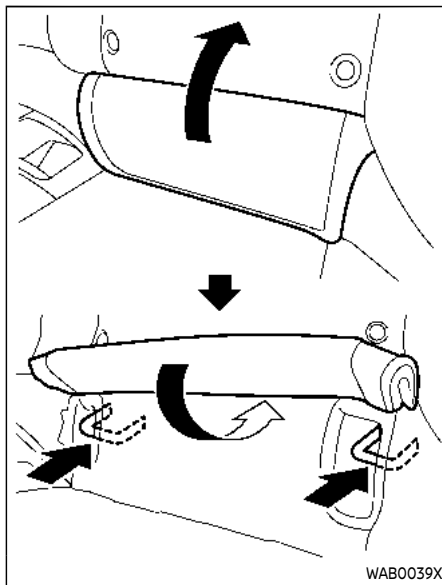

LATCH lower anchor cover removal (example)

The LATCH lower anchors are located behind the cover. Flip and fold the cover, and fix it with the hook-and-loop fastener as shown. A label is attached to the seatback to help you locate the LATCH lower anchors.

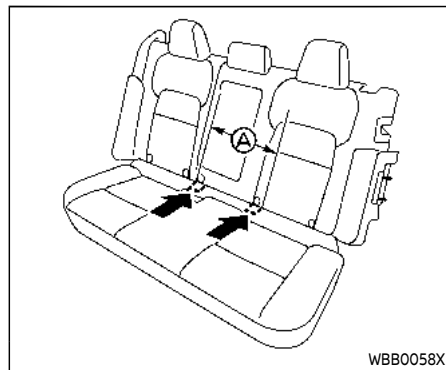

LATCH in the center rear seating position

A 5th LATCH anchor can be found between the outboard LATCH anchor pairs. It is specifically designed to be used together with the inboard LATCH anchor on the driver's side, in order to install a CRS in the rear center seating position.

These anchors utilize standard LATCH anchor spacing, Ⓐ of 11.02 in (280mm).



WARNING

Never attach two CRS attachments to the same LATCH anchor. This may overload the anchor in a collision, which could increase the risk of the occupant's serious injury or death.

When installing the CRS in the center rear seating position with the in-board LATCH anchors, be careful to ensure any occupant or CRS in the outboard seating positions is properly restrained using the vehicle seat belt and there is no interference with the center CRS installation. If the outboard occupants cannot be properly restrained, consider using the vehicle seat belt to restrain the CRS in the center seating position, or moving the CRS to another position instead.

When installing a CRS in the center seating position, use the seat back recline feature to align the left and right sides of the seat back, creating one evenly reclined surface. Never install a CRS in the center seating position when one part of the seat back is further reclined than the other. This may create an unstable surface on which to install the CRS.

Failure to evenly recline the seat backs before CRS installation could increase the risk of the occupant's serious injury or death. Remember to re-check that the CRS is properly installed any time the seats are reclined or adjusted.

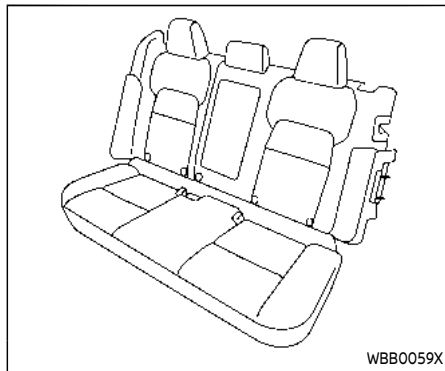

OK (the seatback recline is aligned)

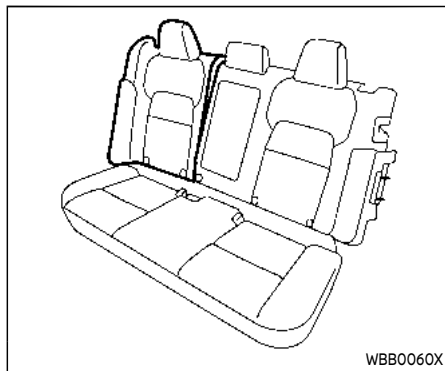

NG (the seatback recline is not aligned)

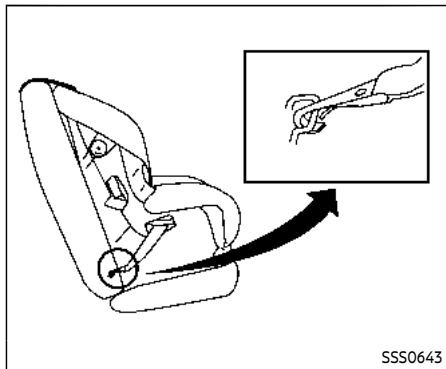

LATCH webbing-mounted attachment

Installing child restraint LATCH lower anchor attachments

LATCH compatible child restraints include two rigid or webbing-mounted attachments that can be connected to two anchors located at certain seating positions in your vehicle. With this system, you do not have to use a vehicle seat belt to secure the child restraint. Check your child restraint for a label stating that it is compatible with LATCH. This information may also be in the instructions provided by the child restraint manufacturer.

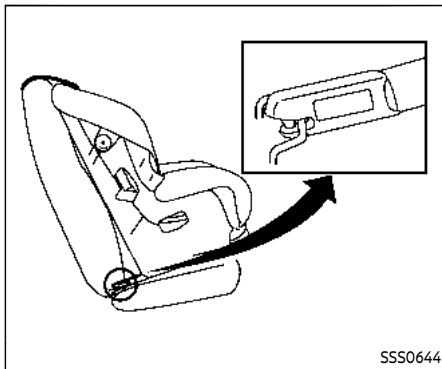

LATCH rigid-mounted attachment

When installing a child restraint, carefully read and follow the instructions in this manual and those supplied with the child restraint.

Top tether anchor

WARNING

Properly secure cargo and do not allow it to contact the top tether strap when it is attached to the top tether anchor. Cargo that is not properly secured or cargo that contacts the top tether strap may damage the top tether strap during a

collision. If the cargo cover (if so equipped) contacts the top tether strap when it is attached to the top tether anchor, remove the cargo cover from the vehicle. If the cargo cover is not removed, it may damage the top tether strap during a collision. Your child could be seriously injured or killed in a collision if the child restraint top tether strap is damaged.

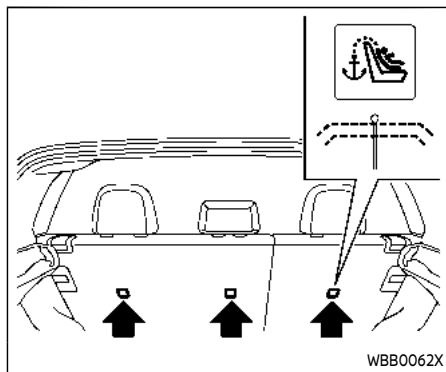

Top tether anchor point locations



WARNING

Child restraint anchorages are designed to withstand only those loads imposed by correctly fitted child restraints. Under no circumstances are they to be used to attach adult seat belts, or other items or equipment to the vehicle. Doing so could damage the child restraint anchorages. The child restraint will not be properly installed using the damaged anchorage, and a child could be seriously injured or killed in a

collision.

Anchor points are located on the back side of the seatbacks.

If a child restraint has a top tether strap, it must be used when installing with the LATCH lower anchor attachments or seat belts as instructed by the child restraint manufacturer.

If you have any questions when installing a top tether strap child restraint on the rear seat, it is recommended you visit a NISSAN certified ARIYA dealer for this service.

REAR-FACING CHILD RESTRAINT INSTALLATION USING LATCH

For additional information, refer to all Warnings and Cautions in the "Child safety" and "Child restraints" sections before installing a child restraint.

Do not use the lower anchors if the combined weight of the child and the child restraint exceeds 65 lbs (29.5 kg). If the combined weight of the child and the child restraint is greater than 65 lbs (29.5 kg), use the vehicle's seat belt (not the lower anchors) to install the child restraint. Be sure to follow the child restraint manufacturer's instructions for installation.

Follow these steps to install a rear-facing child restraint using the LATCH system:

1. Position the child restraint on the seat. Always follow the child restraint manufacturer's instructions.

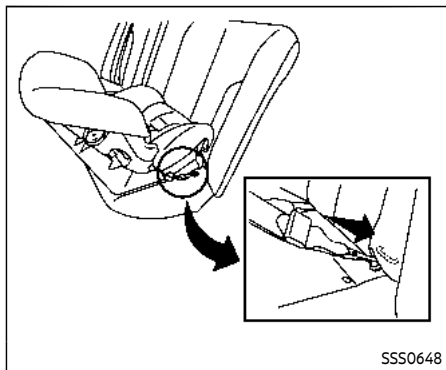

Rear-facing web-mounted — step 2

2. Secure the child restraint anchor attachments to the LATCH lower anchors. Check to make sure the LATCH attachment is properly attached to the lower anchors.

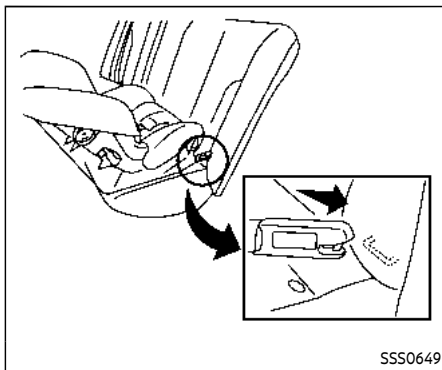

Rear-facing rigid-mounted — step 2

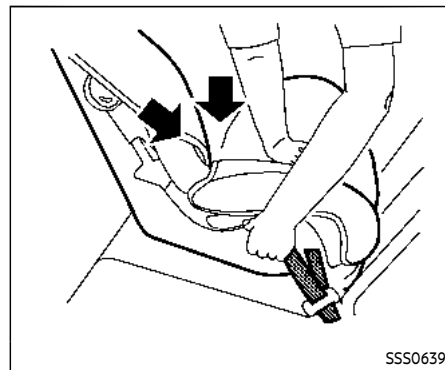

Rear-facing — step 3

3. For child restraints that are equipped with webbing-mounted attachments, remove any additional slack from the anchor attachments. Press downward and rearward firmly in the center of the child restraint with your hand to compress the vehicle seat cushion and seatback while tightening the webbing of the anchor attachments.

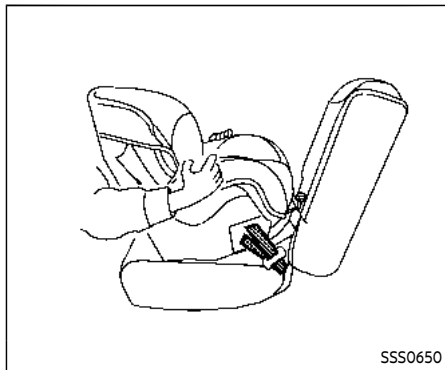

Rear-facing — step 4

4. After attaching the child restraint, test it before you place the child in it. Push it from side to side while holding the child restraint near the LATCH attachment path. The child restraint should not move more than 1 inch (25 mm), from side to side. Try to tug it forward and check to see if the LATCH attachment holds the restraint in place. If the restraint is not secure, tighten the LATCH attachment as necessary, or put the restraint in another seat, or test it again. You may need to try a different child restraint or try installing by using the vehicle seat belt (if applicable). Not all child restraints fit

in all types of vehicles.

5. Check to make sure the child restraint is properly secured prior to each use. If the child restraint is loose, repeat steps 1 through 4.

REAR-FACING CHILD RESTRAINT INSTALLATION USING THE SEAT BELTS



WARNING

The three-point seat belt with Automatic Locking Retractor (ALR) must be used when installing a child restraint. Failure to use the ALR mode will result in the child restraint not being properly secured. The restraint could tip over or be loose and cause injury to a child in a sudden stop or collision.

For additional information, refer to all Warnings and Cautions in the "Child safety" and "Child restraints" sections before installing a child restraint.

Do not use the lower anchors if the combined weight of the child and the child restraint exceeds 65 lbs (29.5 kg). If the combined weight of the child and the child restraint is greater than 65 lbs (29.5

kg), use the vehicle's seat belt (not the lower anchors) to install the child restraint. Be sure to follow the child restraint manufacturer's instructions for installation.

Follow these steps to install a rear-facing child restraint using the vehicle seat belts in the rear seats:

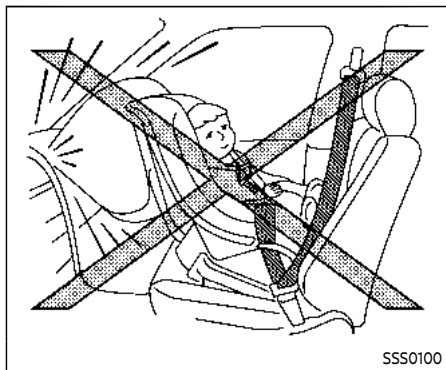

Rear-facing — step 1

1. **Child restraints for infants must be used in the rear-facing direction and therefore must not be used in the front seat.** Position the child restraint on the seat. Always follow the restraint manufacturer's instructions.

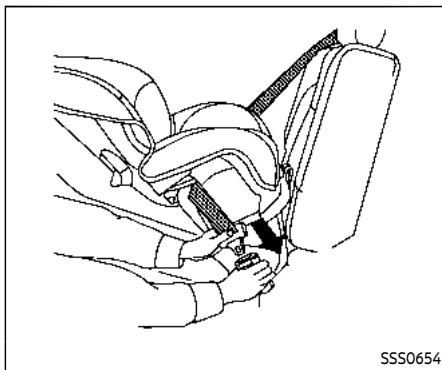

Rear-facing — step 2

2. Route the seat belt tongue through the child restraint and insert it into the buckle until you hear and feel the latch engage. Be sure to follow the child restraint manufacturer's instructions for belt routing.

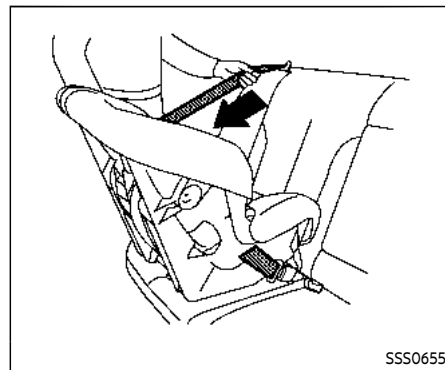

Rear-facing — step 3

3. Pull the shoulder belt until the belt is fully extended. At this time, the seat belt retractor is in the Automatic Locking Retractor (ALR) mode (child restraint mode). It reverts to the Emergency Locking Retractor (ELR) mode when the seat belt is fully retracted.

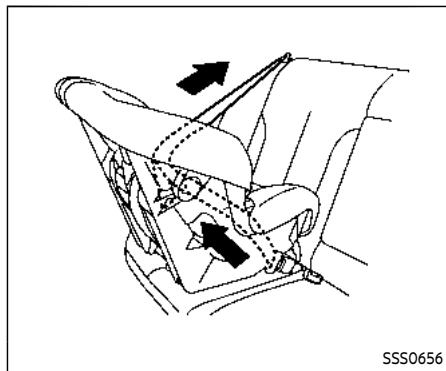

Rear-facing — step 4

4. Allow the seat belt to retract. Pull up on the shoulder belt to remove any slack in the belt.

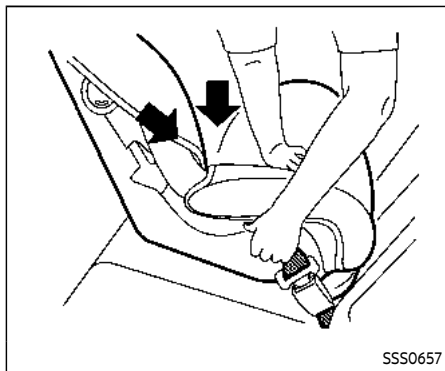

Rear-facing — step 5

5. Remove any additional slack from the seat belt; press downward and rearward firmly in the center of the child restraint to compress the vehicle seat cushion and seatback while pulling up on the seat belt.

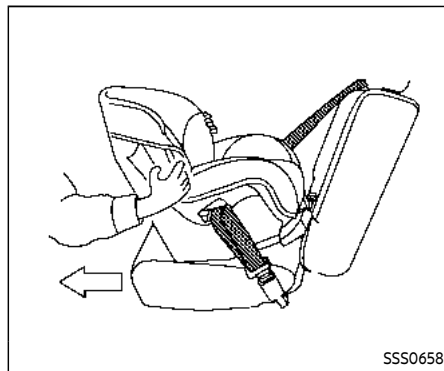

Rear-facing — step 6

6. After attaching the child restraint, test it before you place the child in it. Push it from side to side while holding the child restraint near the seat belt path. The child restraint should not move more than 1 inch (25 mm), from side to side. Try to tug it forward and check to see if the belt holds the restraint in place. If the restraint is not secure, tighten the seat belt as necessary, or put the restraint in another seat and test it again. You may need to try a different child restraint. Not all child restraints fit in all types of vehicles.
7. Check to make sure that the child restraint is properly secured prior to

each use. If the seat belt is not locked, repeat steps 1 through 6.

After the child restraint is removed and the seat belt fully retracted, the ALR mode (child restraint mode) is canceled.

FORWARD-FACING CHILD RESTRAINT INSTALLATION USING LATCH

For additional information, refer to all Warnings and Cautions in the "Child safety" and "Child restraints" sections before installing a child restraint.

Do not use the lower anchors if the combined weight of the child and the child restraint exceeds 65 lbs (29.5 kg). If the combined weight of the child and the child restraint is greater than 65 lbs (29.5 kg), use the vehicle's seat belt (not the lower anchors) to install the child restraint. Be sure to follow the child restraint manufacturer's instructions for installation.

Follow these steps to install a forward-facing child restraint using the LATCH system:

1. Position the child restraint on the seat. Always follow the child restraint manufacturer's instructions.

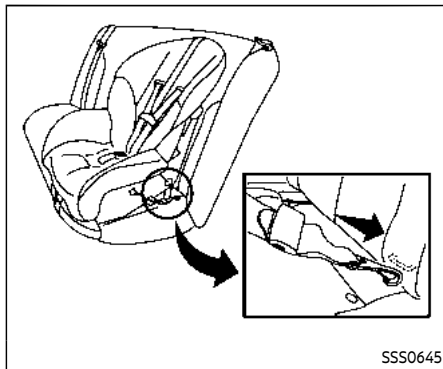

Forward-facing web-mounted — step 2

2. Secure the child restraint anchor attachments to the LATCH lower anchors. Check to make sure the LATCH attachment is properly attached to the lower anchors.

If the child restraint is equipped with a top tether strap, route the top tether strap and secure the tether strap to the tether anchor point. See "Installing top tether strap" (P.1-39). Do not install child restraints that require the use of a top tether strap in seating positions that do not have a top tether anchor.

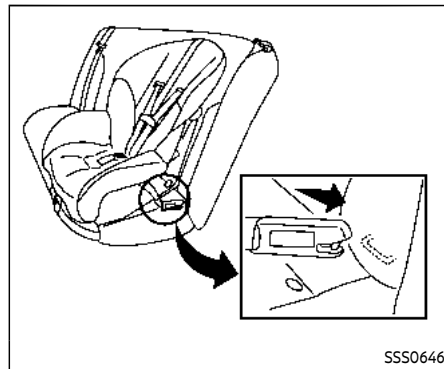

Forward-facing rigid-mounted — step 2

3. The back of the child restraint should be secured against the vehicle seat-back.

If necessary, adjust or remove the head restraint/headrest to obtain the correct child restraint fit. If the head restraint/headrest is removed, store it in a secure place. **Be sure to reinstall the head restraint/headrest when the child restraint is removed.** See "Head restraints/headrests" (P.1-10) for head restraint/headrest adjustment information.

If the seating position does not have an adjustable head restraint/headrest and it is interfering with the proper

child restraint fit, try another seating position or a different child restraint.

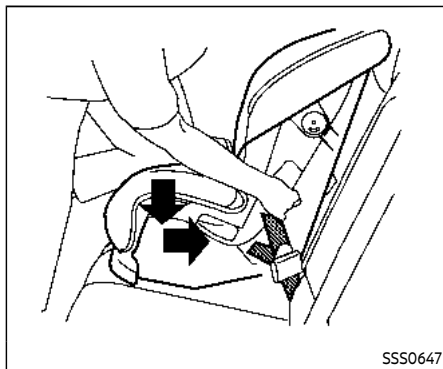

Forward-facing — step 4

4. For child restraints that are equipped with webbing-mounted attachments, remove any additional slack from the anchor attachments. Press downward and rearward firmly in the center of the child restraint with your knee to compress the vehicle seat cushion and seatback while tightening the webbing of the anchor attachments.
5. Tighten the tether strap according to the manufacturer's instructions to remove any slack.

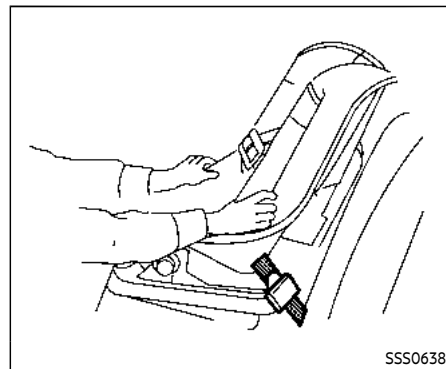

Forward-facing — step 6

6. After attaching the child restraint, test it before you place the child in it. Push it from side to side while holding the child restraint near the LATCH attachment path. The child restraint should not move more than 1 inch (25 mm), from side to side. Try to tug it forward and check to see if the LATCH attachment holds the restraint in place. If the restraint is not secure, tighten the LATCH attachment as necessary, or put the restraint in another seat and test it again. You may need to try a different child restraint. Not all child restraints fit in all types of vehicles.

7. Check to make sure the child restraint is properly secured prior to each use. If the child restraint is loose, repeat steps 1 through 6.

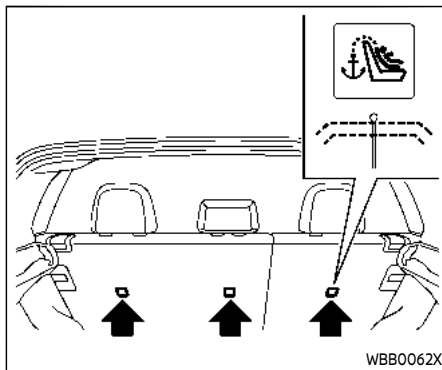

Installing top tether strap

WARNING

- **Child restraint anchorages are designed to withstand only those loads imposed by correctly fitted child restraints. Under no circumstances are they to be used to attach adult seat belts, or other items or equipment to the vehicle. Doing so could damage the child restraint anchorages. The child restraint will not be properly installed using the damaged anchorage, and a child could be**

seriously injured or killed in a collision.

- **Do not hook the top tether strap on the seatback carpet. Be sure to use the tether anchor point to secure the top tether strap.**

The child restraint top tether strap must be used when installing forward-facing child restraint with the LATCH lower anchor attachments.

First, secure the child restraint with the LATCH lower anchors.

1. Remove the head restraint/headrest and store it in a secure place. Be sure to reinstall the head restraint/headrest when the child restraint is removed.
2. Position the top tether strap as shown.
3. Secure the top tether strap to the tether anchor point as shown.
4. Refer to the appropriate child restraint installation procedure steps in this section before tightening the tether strap.

If you have any questions when installing a top tether strap, it is recommended that you visit a NISSAN certified ARIYA dealer for this service.

FORWARD-FACING CHILD RESTRAINT INSTALLATION USING THE SEAT BELTS

WARNING

The three-point seat belt with Automatic Locking Retractor (ALR) must be used when installing a child restraint. Failure to use the ALR mode will result in the child restraint not being properly secured. The restraint could tip over or be loose and cause injury to a child in a sudden stop or collision. Also, it can change the operation of the front passenger air bag. See "Front passenger air bag and status light" (P.1-56).

For additional information, refer to all Warnings and Cautions in the "Child safety" and "Child restraints" sections before installing a child restraint.

Do not use the lower anchors if the combined weight of the child and the child restraint exceeds 65 lbs (29.5 kg). If the combined weight of the child and the

child restraint is greater than 65 lbs (29.5 kg), use the vehicle's seat belt (not the lower anchors) to install the child restraint. Be sure to follow the child restraint manufacturer's instructions for installation.

Follow these steps to install a forward-facing child restraint using the vehicle seat belt in the rear seats or in the front passenger seat:

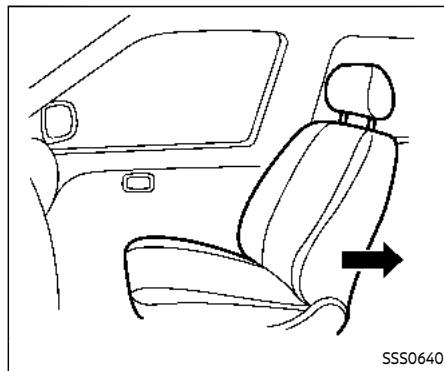

Forward-facing (front passenger seat) — step 1

1. **If you must install a child restraint in the front seat, it should be placed in a forward-facing direction only. Move the seat to the rearmost position. Child restraints for infants must be used in the rear-facing direction and, therefore, must not be used in the front seat.**
2. Position the child restraint on the seat. Always follow the child restraint manufacturer's instructions.
The back of the child restraint should be secured against the vehicle seatback.
If necessary, adjust or remove the head restraint/headrest to obtain the

correct child restraint fit. If the head restraint/headrest is removed, store it in a secure place. **Be sure to reinstall the head restraint/headrest when the child restraint is removed.** See "Head restraints/headrests" (P.1-10) for head restraint/headrest adjustment, removal and installation information.

If the seating position does not have an adjustable head restraint/headrest and it is interfering with the proper child restraint fit, try another seating position or a different child restraint.

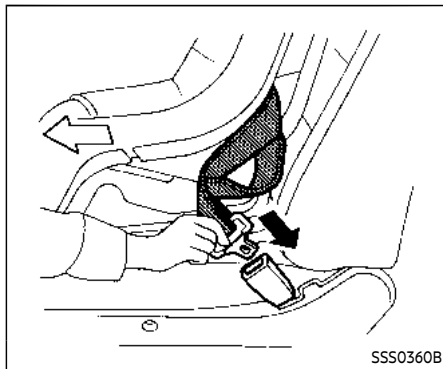

Forward-facing — step 3

3. Route the seat belt tongue through the child restraint and insert it into the buckle until you hear and feel the latch engage. Be sure to follow the child restraint manufacturer's instructions for belt routing.

If the child restraint is equipped with a top tether strap, route the top tether strap and secure the tether strap to the tether anchor point (rear seat installation only). See "Installing top tether strap" (P.1-43). Do not install child restraints that require the use of a top tether strap in seating positions that do not have a top tether anchor.

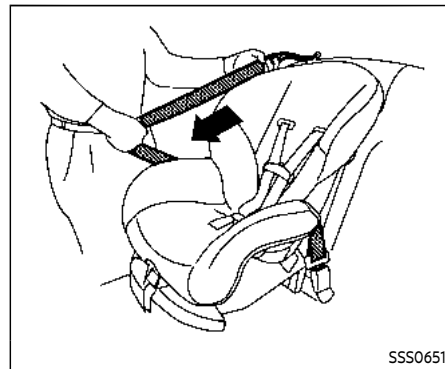

Forward-facing — step 4

4. Pull the shoulder belt until the belt is fully extended. At this time, the seat belt retractor is in the Automatic Locking Retractor (ALR) mode (child restraint mode). It reverts to Emergency Locking Retractor (ELR) mode when the seat belt is fully retracted.

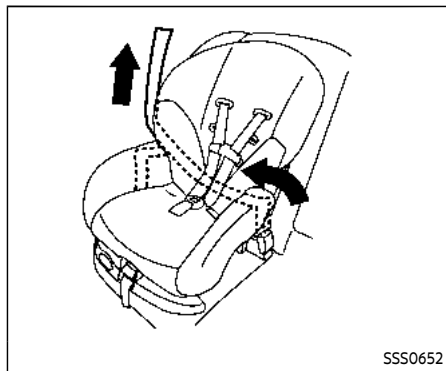

Forward-facing — step 5

5. Allow the seat belt to retract. Pull up on the shoulder belt to remove any slack in the belt.

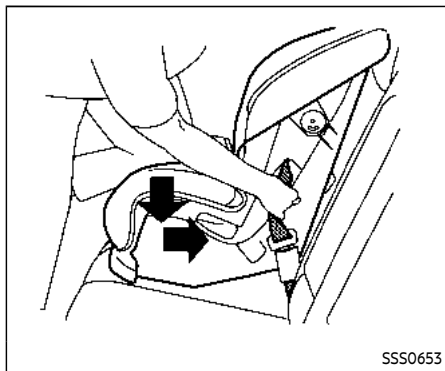

Forward-facing — step 6

6. Remove any additional slack from the seat belt; press downward and rearward firmly in the center of the child restraint with your knee to compress the vehicle seat cushion and seatback while pulling up on the seat belt.
7. Tighten the tether strap according to the manufacturer's instructions to remove any slack.

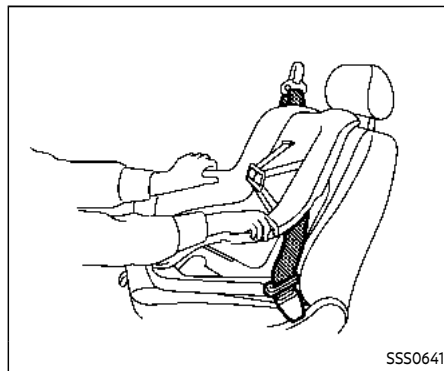

Forward-facing — step 8

8. After attaching the child restraint, test it before you place the child in it. Push it from side to side while holding the child restraint near the seat belt path. The child restraint should not move more than 1 inch (25 mm), from side to side. Try to tug it forward and check to see if the belt holds the restraint in place. If the restraint is not secure, tighten the seat belt as necessary, or put the restraint in another seat and test it again. You may need to try a different child restraint. Not all child restraints fit in all types of vehicles.
9. Check to make sure the child restraint is properly secured prior to each use. If

the seat belt is not locked, repeat steps 2 through 8.

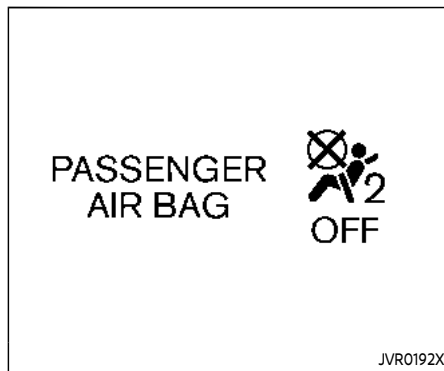

Forward-facing — step 10

10. If the child restraint is installed in the front passenger seat, place the power switch in the ON position. The front passenger air bag status light  should illuminate. If this light is not illuminated, see "Front passenger air bag and status light" (P.1-56). **Move the child restraint to another seating position.** Have the system checked. It is recommended you visit a NISSAN certified ARIYA dealer for this service.

After the child restraint is removed and the seat belt is fully retracted, the ALR mode (child restraint mode) is canceled.

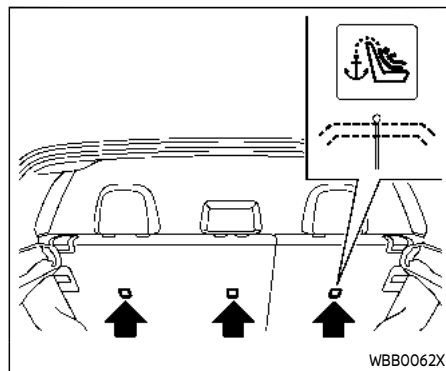

Installing top tether strap



WARNING

- **Child restraint anchorages are designed to withstand only those loads imposed by correctly fitted child restraints. Under no circumstances are they to be used to attach adult seat belts, or other items or equipment to the vehicle. Doing so could damage the child restraint anchorages. The child restraint will not be properly installed using the damaged anchorage, and a child could be**

seriously injured or killed in a collision.

- **Do not hook the top tether strap on the seatback carpet. Be sure to use the tether anchor point to secure the top tether strap.**

The child restraint top tether strap must be used when installing forward-facing child restraint with the seat belts.

First, secure the child restraint with the seat belt.

1. Remove the head restraint/headrest and store it in a secure place. Be sure to reinstall the head restraint/headrest when the child restraint is removed.

See "Head restraints/headrests" (P.1-10) for head restraint/headrest adjustment, removal and installation information.

2. Position the top tether strap as shown.
3. Secure the top tether strap to the tether anchor point as shown.
4. Refer to the appropriate child restraint installation procedure steps in this section before tightening the tether strap.

If you have any questions when instal-

ling a top tether strap, it is recommended you visit a NISSAN certified ARIYA dealer for this service.

BOOSTER SEATS

For additional information on installing a booster seat in your vehicle, follow the instructions outlined in this section.

Precautions on booster seats



WARNING

If a booster seat and seat belt are not used properly, the risk of a child being injured or killed in a sudden stop or collision greatly increases:

- **Make sure the shoulder portion of the belt is away from the child's face and neck and the lap portion of the belt does not cross the stomach.**
- **Make sure the shoulder belt is not behind the child or under the child's arm.**
- **A booster seat must only be installed in a seating position that has a lap/shoulder belt.**

Booster seats of various sizes are offered by several manufacturers. When selecting

any booster seat, keep the following points in mind:

- Choose only a booster seat with a label certifying that it complies with Federal Motor Vehicle Safety Standard 213 or Canadian Motor Vehicle Safety Standard 213.
- Check the booster seat in your vehicle to be sure it is compatible with the vehicle's seat and seat belt system.

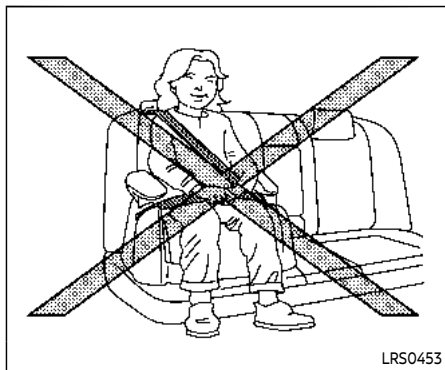

- Make sure the child's head will be properly supported by the booster seat or vehicle seat. The seatback must be at or above the center of the child's ears. For example, if a low back booster seat ① is chosen, the vehicle seatback must be at or above the center of the child's ears. If the seatback is lower than the center of the child's ears, a high back booster seat ② should be used.
- If the booster seat is compatible with your vehicle, place your child in the booster seat and check the various adjustments to be sure the booster seat is compatible with your child. Always follow all recommended procedures.

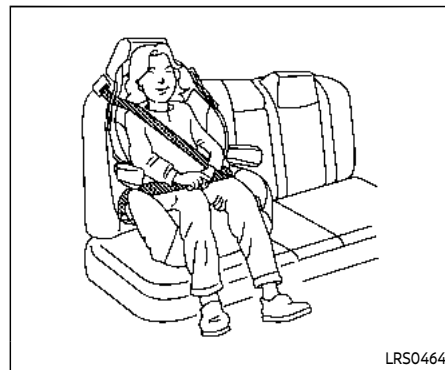

All U.S. states and Canadian provinces or territories require that infants and small children be restrained in an approved child restraint at all times while the vehicle is being operated.

The instructions in this section apply to booster seat installation in the rear seats or the front passenger seat.

Booster seat installation



WARNING

To avoid injury to child, do not use the lap/shoulder belt Automatic Locking Retractor (ALR) mode when

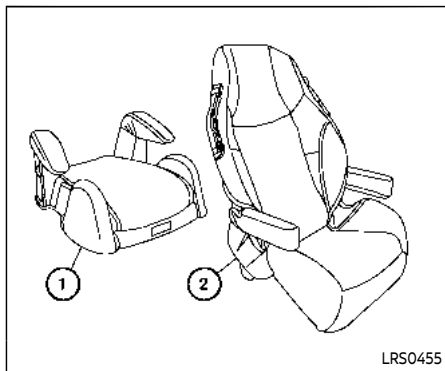

using a booster seat with the seat belts.

For additional information, refer to all Warnings and Cautions in the "Child safety", "Child restraints" and "Booster seats" sections earlier in this section before installing a child restraint.

Follow these steps to install a booster seat in the rear seat or in the front passenger seat:

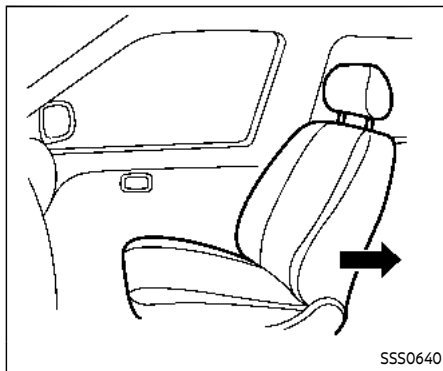

1. **If you must install a booster seat in the front seat, move the seat to the rearmost position.**
2. Position the booster seat on the seat. Only place it in a forward-facing direction. Always follow the booster seat manufacturer's instructions.

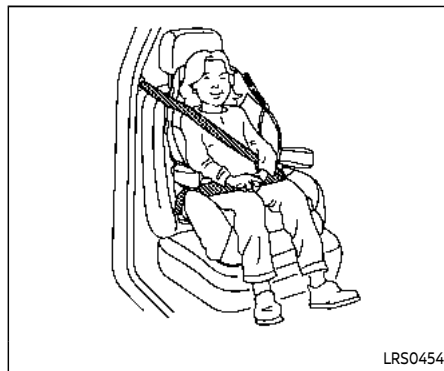

Front passenger position

3. The booster seat should be positioned on the vehicle seat so that it is stable. If necessary, adjust or remove the head restraint/headrest to obtain the correct booster seat fit. If the head restraint/headrest is removed, store it in a secure place. **Be sure to reinstall the head restraint/headrest when the booster seat is removed.** See "Head restraints/headrests" (P.1-10) for head restraint/headrest adjustment, removal and installation information.

If the head restraint/headrest of the seating position is interfering with the proper booster seat fit, try another

seating position or a different booster seat.

4. Position the lap portion of the seat belt low and snug on the child's hips. Be sure to follow the booster seat manufacturer's instructions for adjusting the seat belt routing.
5. Pull the shoulder belt portion of the seat belt toward the retractor to take up extra slack. Be sure the shoulder belt is positioned across the top, middle portion of the child's shoulder. Be sure to follow the booster seat manufacturer's instructions for adjusting the seat belt routing.
6. Follow the warnings, cautions and instructions for properly fastening a seat belt shown in "Seat belts" (P.1-14).



7. If the booster seat is installed in the front passenger seat, place the power switch in the ON position. The front passenger air bag status light  may or may not illuminate depending on the size of the child and the type of booster seat used. See "Front passenger air bag and status light" (P.1-56).

SUPPLEMENTAL RESTRAINT SYSTEM (SRS)

PRECAUTIONS ON SRS

This SRS section contains important information concerning the following systems:

- Driver and front passenger supplemental front-impact air bag (NISSAN Advanced Air Bag System)
- Driver and front passenger supplemental knee air bag
- Front seat-mounted side-impact supplemental air bag
- Rear outboard seat-mounted side-impact supplemental air bag
- Front central seat-mounted side-impact supplemental air bag (if so equipped)
- Roof-mounted curtain side-impact and rollover supplemental air bag
- Seat belt with pretensioner (front and rear outboard seats)

Supplemental front-impact air bag system: The NISSAN Advanced Air Bag System can help cushion the impact force to the head and chest of the driver and front passenger in certain frontal collisions.

Driver and front passenger supplemental knee air bag system: This system can help cushion the impact force to the driver's and front passenger's knees in certain collisions.

Front seat-mounted side-impact supplemental air bag system: This system can help cushion the impact force to the chest and pelvic area of the driver and front passenger in certain side impact collisions. The side air bag is designed to inflate on the side where the vehicle is impacted.

Rear outboard seat-mounted side-impact supplemental air bag system: This system can help cushion the impact force to the chest and pelvic area of the rear outboard seat passengers in certain side-impact collisions. The side air bags are designed to inflate on the side where the vehicle is impacted.

Front central seat-mounted side-impact supplemental air bag (if so equipped): This system can help cushion the impact force to the head area of the driver and front passenger in certain side-impact collisions. The front central side-impact air bag is designed to inflate in the front central area where the vehicle is impacted.

Roof-mounted curtain side-impact and rollover supplemental air bag system: This system can help cushion the impact force to the heads of occupants in front and rear outboard seating positions in certain side impact or rollover collisions. In a side-impact, the curtain air bags are

designed to inflate on the side where the vehicle is impacted. In a rollover, the curtain air bags on both sides are designed to inflate. Under both side-impact and rollover situations, the curtain air bags will remain inflated for a short period of time.

These supplemental restraint systems are designed to **supplement** the crash protection provided by the driver, passenger and rear outboard seat belts and are **not a substitute** for them. Seat belts should always be correctly worn and the occupant seated a suitable distance away from the steering wheel, instrument panel and door finishers. (See "Seat belts" (P.1-14) for instructions and precautions on seat belt usage.)

The supplemental air bags operate only when the power switch is in the ON position.

After the power is placed in the ON position, the supplemental air bag warning light illuminates. The supplemental air bag warning light will turn off after about 7 seconds if the systems are operational.

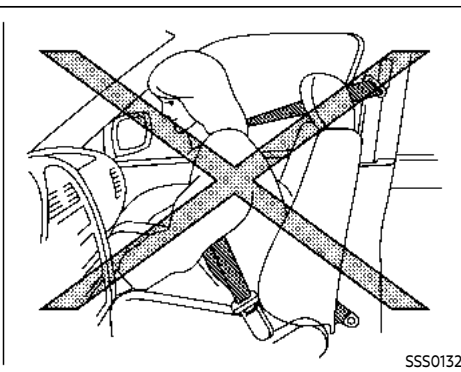
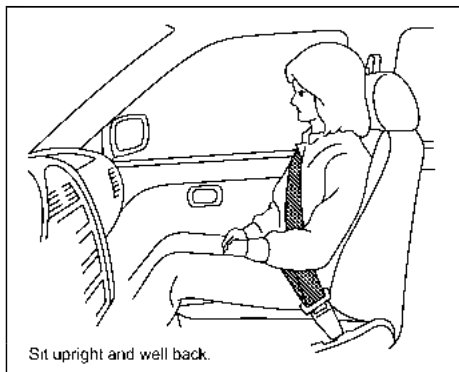
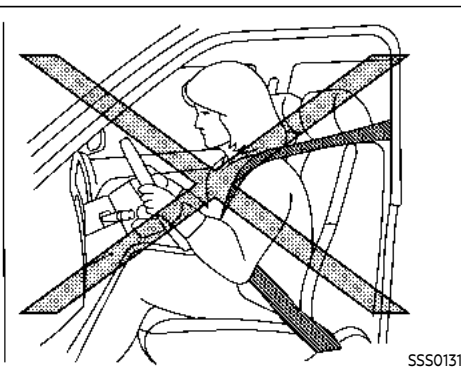
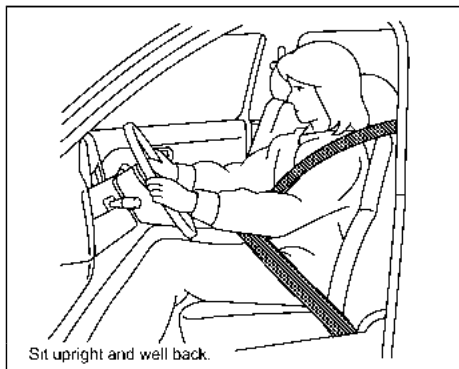

WARNING

- The front air bags ordinarily will not inflate in the event of a side impact, rear impact, rollover, or lower severity frontal collision. Always wear your seat belts to help reduce the risk or severity of injury in various kinds of accidents.
- The front passenger air bag and passenger knee air bag will not inflate if the front passenger air bag status light is lit. See "Front passenger air bag and status light" (P.1-56).
- The seat belts and the front air bags are most effective when you are sitting well back and upright in the seat with both feet on the floor. The front air bags inflate with great force. Even with the NISSAN Advanced Air Bag System, if you are unrestrained, leaning forward, sitting sideways or out of position in any way, you are at greater risk of injury or death in a crash. You may also receive serious or fatal injuries from the front air bag if you are up against it when it inflates. Always sit back

against the seatback and as far away as practical from the steering wheel or instrument panel. Always properly use the seat belts.

- The driver and front passenger seat belt buckles are equipped with sensors that detect if the seat belts are fastened. The Advanced Air Bag System monitors the severity of a collision and seat belt usage then inflates the air bags as needed. Failure to properly wear seat belts can increase the risk or severity of injury in an accident.
- The front passenger seat is equipped with occupant classification sensors (weight sensors) that turn the front passenger air bag and front passenger knee air bag OFF under some conditions. These sensors are only used in this seat. Failure to be properly seated and wearing the seat belt can increase the risk or severity of injury in an accident. See "Front passenger air bag and status light" (P.1-56).
- Keep hands on the outside of the steering wheel. Placing them inside the steering wheel rim could

increase the risk that they are injured if the front air bag inflates.

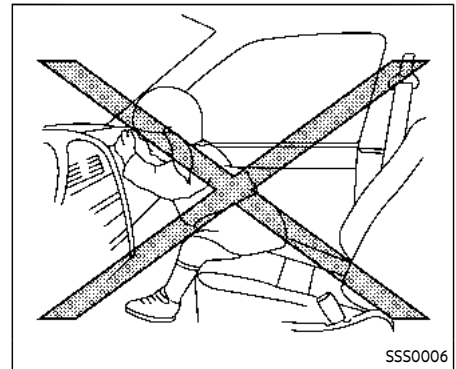
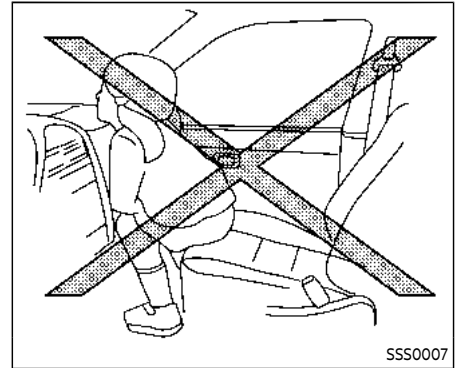

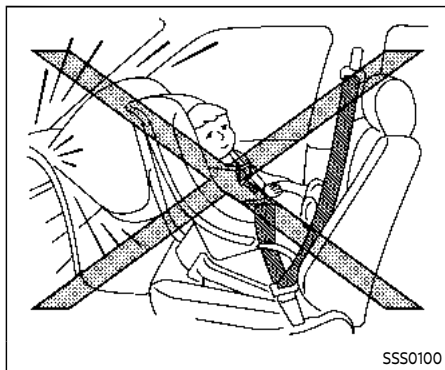
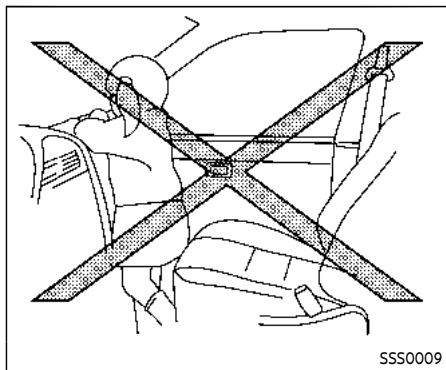
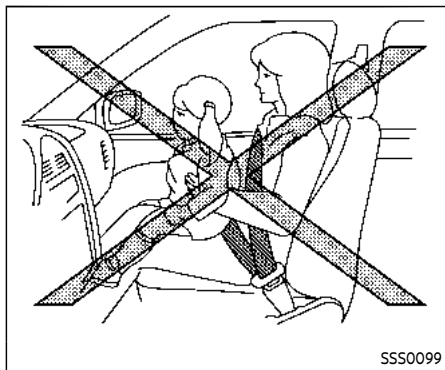
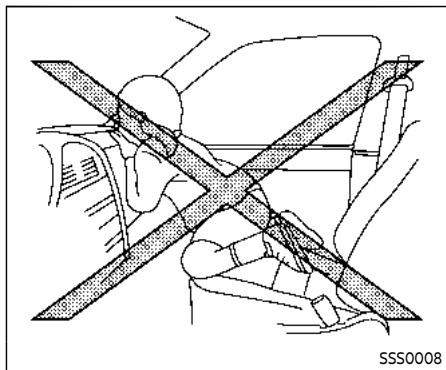

WARNING

- Never let children ride unrestrained or extend their hands or face out of the window. Do not attempt to hold them in your lap or arms. Some examples of dangerous riding positions are shown in the illustrations.
- Children may be severely injured or killed when the front air bags, side air bags or curtain air bags inflate if they are not properly restrained. Pre-teens and children should be properly restrained in the rear seat, if possible.
- Even with the NISSAN Advanced Air Bag System, never install a rear-facing child restraint in the front seat. An inflating front air bag could seriously injure or kill your child. See "Child restraints" (P.1-26) for details.

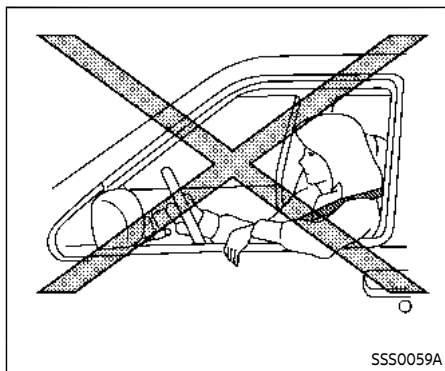

Do not lean against doors or windows.

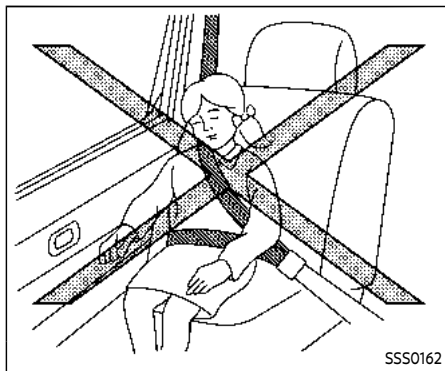
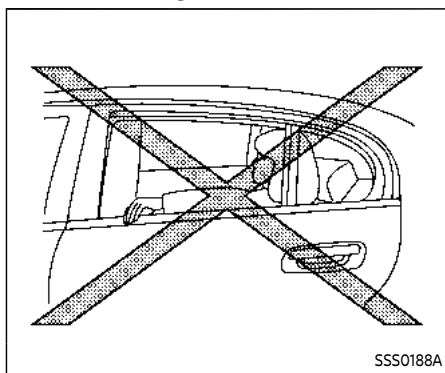
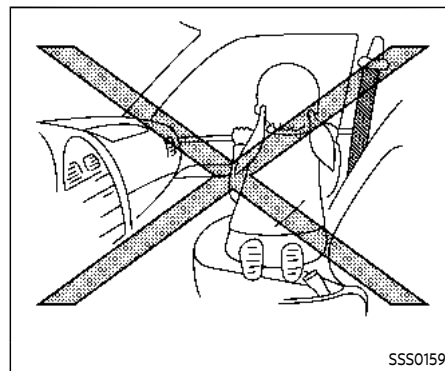
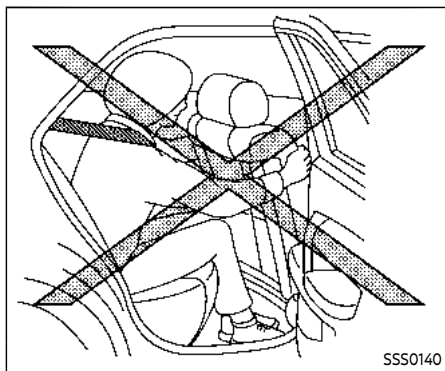

⚠ WARNING

Front, front central and rear out-board seat-mounted side-impact supplemental air bags and roof-mounted curtain side-impact and rollover supplemental air bags:

- The side air bags ordinarily will not inflate in the event of a frontal impact, rear impact, roll-over or lower severity side collision. Always wear your seat belts to help reduce the risk or severity of injury in various kinds of accidents.

- The curtain air bags ordinarily will not inflate in the event of a front impact, rear impact, or lower severity side collision. Always wear your seat belts to help reduce the risk or severity of injury in various kinds of accidents.
- The seat belts, the side air bags and curtain air bags are most effective when you are sitting well back and upright in the seat. The side air bags and curtain air bags inflate with great force. Do not allow anyone to place their hand, leg or face near the side air bags on the side of the seatback of the front and rear seat or near the side roof rails. Do not allow anyone sitting in the front seats or rear outboard seats to extend their hand out of the window or lean against the door. Some examples of dangerous riding positions are shown in the previous illustrations.
- When sitting in the rear seat, do not hold onto the seatback of the front seat. If the side air bags inflate, you may be seriously injured. Be especially careful with children, who should always be

properly restrained. Some examples of dangerous riding positions are shown in the illustrations.

- Do not use seat covers on the front and rear seatbacks. They may interfere with side air bag inflation.

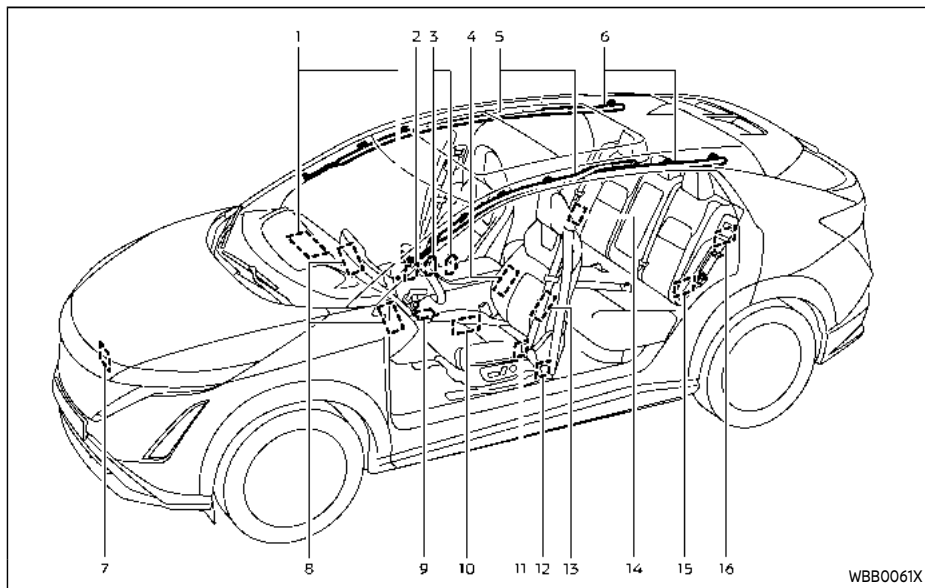

- | | |
|---|---|
| <ol style="list-style-type: none"> 1. Supplemental front-impact air bag modules (NISSAN Advanced Air Bags) 2. Occupant classification system control unit 3. Occupant classification sensors (weight sensors) 4. Front central seat-mounted side-impact supplemental air bag (if so equipped) | <ol style="list-style-type: none"> 5. Roof-mounted curtain side-impact and rollover supplemental air bag inflators 6. Roof-mounted curtain side-impact and rollover supplemental air bag modules 7. Crash zone sensor 8. Driver and front passenger supplemental knee air bags 9. Air bag Control Unit (ACU) |
|---|---|

10. Front door pressure sensors (driver's side shown; front passenger side similar)
11. Lap outer pretensioners (front seats)
12. Seat belt with pretensioners (front seats)
13. Front seat-mounted side-impact supplemental air bag modules (driver's side shown; front passenger side similar)
14. Rear outboard seat-mounted side-impact supplemental air bag modules (front passenger side shown; driver's side similar)
15. Satellite sensors (driver's side shown; front passenger side similar)
16. Seat belt with pretensioners (driver's side shown; front passenger side similar)

NISSAN ADVANCED AIR BAG SYSTEM (front seats)



WARNING

To ensure proper operation of the passenger's Advanced Air Bag system, please observe the following items.

- Do not allow a passenger in the rear seat to push or pull on the seatback pocket.
- Do not place heavy loads heavier than 9.1 lbs (4 kg) on the seatback, head restraint or in the seatback pocket.

- **Make sure nothing is pressing against the rear of the seatback, such as a child restraint installed in the rear seat or an object stored on the floor.**
- **Make sure that there is no object placed under the front passenger seat.**
- **Make sure that there is no object placed between the seat cushion and center console or between the seat cushion and the door.**
- **Be sure that the front passenger seat does not contact the rear seat, instrument panel, etc., or the head restraint does not contact the roof.**
- **Do not position the front passenger seat so it contacts the rear seat. If the front seat does contact the rear seat, the air bag system may determine a sensor malfunction has occurred and the front passenger air bag status light may illuminate and the supplemental air bag warning light may flash.**
- **If a forward facing child restraint is installed in the front passenger seat, do not position the front passenger seat so the child re-**

straint contacts the instrument panel. If the child restraint does contact the instrument panel, the system may determine the seat is occupied and the passenger air bag and front passenger knee air bag may deploy in a collision. Also the front passenger air bag status light may not illuminate. See "Child restraints" (P.1-26) for information about installing and using child restraints.

- **Confirm the operating condition with the front passenger air bag status light.**
- **If you notice that the front passenger air bag status light is not operating as described in this section, it is recommended you visit a NISSAN certified ARIYA dealer to check the passenger seat Advanced Air Bag System.**
- **Until you have confirmed with your dealer that your passenger seat Advanced Air Bag is working properly, position the occupants in the rear seating positions.**

This vehicle is equipped with the NISSAN Advanced Air Bag System for the driver and front passenger seats. This system is designed to meet certification require-

ments under U.S. regulations. It is also permitted in Canada. **All of the information, cautions and warnings in this manual apply and must be followed.**

The driver supplemental front-impact air bag is located in the center of the steering wheel. The passenger supplemental front-impact air bag is mounted in the instrument panel above the glove box. The front air bags are designed to inflate in higher severity frontal collisions, although they may inflate if the forces in another type of collision are similar to those of a higher severity frontal impact. They may not inflate in certain frontal collisions. Vehicle damage (or lack of it) is not always an indication of proper front air bag operation.

The NISSAN Advanced Air Bag System has dual stage air bag inflators. The system monitors information from the Air bag Control Unit (ACU), seat belt buckle sensors and the occupant classification sensors (weight sensors). Inflator operation is based on the severity of a collision and seat belt usage for the driver. For the front passenger, the occupant classification sensors are also monitored. Based on information from the sensors, only one front air bag may inflate in a crash, depending on the crash severity and whether the front occupants are belted

or unbelted. Additionally, the front passenger air bag and front passenger knee air bag may be automatically turned OFF under some conditions, depending on the information provided by the occupant classification sensors. If the front passenger air bag and front passenger knee air bag are OFF, the front passenger air bag status light will be illuminated. (See "Front passenger air bag and status light" (P.1-56) for further details.) One front air bag inflating does not indicate improper performance of the system.

If you have any questions about your air bag system, it is recommended you visit a NISSAN certified ARIYA dealer to obtain information about the system. If you are considering modification of your vehicle due to a disability, you may also contact NISSAN. Contact information is contained in the front of this Owner's Manual.

When a front air bag inflates, a fairly loud noise may be heard, followed by release of smoke. This smoke is not harmful and does not indicate a fire. Care should be taken not to inhale it, as it may cause irritation and choking. Those with a history of a breathing condition should get fresh air promptly.

Front air bags, along with the use of seat belts, help to cushion the impact force on the head and chest of the front occu-

pants. They can help save lives and reduce serious injuries. However, an inflating front air bag may cause facial abrasions or other injuries. Front air bags, other than the driver's and front passenger's knee air bags, do not provide restraint to the lower body.

Even with NISSAN Advanced Air Bags, seat belts should be correctly worn and the driver and passenger seated upright as far as practical away from the steering wheel or instrument panel. The front air bags inflate quickly in order to help protect the front occupants. Because of this, the force of the front air bag inflating can increase the risk of injury if the occupant is too close to, or is against, the air bag module during inflation.

The front air bags deflate quickly after a collision.

The front air bags operate only when the power switch is in the ON position.

After the power is placed in the ON position, the supplemental air bag warning light illuminates. The supplemental air bag warning light will turn off after about 7 seconds if the system is operational.



Front passenger air bag status light

Front passenger air bag and status light





WARNING

The front passenger air bag and front passenger knee air bag are designed to automatically turn OFF under some conditions. Read this section carefully to learn how it operates. Proper use of the seat, seat belt and child restraints is necessary for most effective protection. Failure to follow all instructions in this manual concern-

ing the use of seats, seat belts and child restraints can increase the risk or severity of injury in an accident.

Status light:

The front passenger seat is equipped with occupant classification sensors (weight sensors) that turn the front passenger air bag and front passenger knee air bag on or off depending on the weight applied to the front passenger seat. The status of the front passenger air bag and front passenger knee air bag (ON or OFF) is indicated by the front passenger air bag status light  which is located on the roof console. After the power switch is placed in the ON position, the front passenger air bag status light illuminates for about 7 seconds and then turns off or remains illuminated depending on the front passenger seat occupied status. The light operates as follows:

CONDITION	DESCRIPTION	PASSENGER AIR BAG INDICATOR LIGHT ()	FRONT PASSENGER AIR BAG AND FRONT PASSENGER KNEE AIR BAG STATUS
Empty	Empty front passenger seat	ON (illuminated)	INHIBITED
Nobody/Somebody	Bag or Child or Child Restraint or Small Adult in front passenger seat	ON (illuminated)	INHIBITED
Adult	Adult in the front passenger seat	OFF (dark)	ACTIVATED

In addition to the above, certain objects placed on the front passenger seat may also cause the light to operate as described above depending on their weight.

For additional information related to the normal operation and troubleshooting of this occupant classification sensor system, please refer to “Normal operation” (P.1-60) and “Troubleshooting” (P.1-61) in this section.

Front passenger air bag:

The front passenger air bag is designed to automatically turn OFF when the vehicle is operated under some conditions as described below as permitted by U.S. regulations. If the front passenger air bag is OFF, it will not inflate in a crash. The driver air bag and other air bags in your vehicle are not part of this system.

The purpose of the regulation is to help reduce the risk of injury or death from an inflating air bag to certain front passenger seat occupants, such as children, by requiring the air bag to be automatically turned OFF. Certain sensors are used to meet the requirements.

The occupant classification sensor in this vehicle is a weight sensor. It is designed to detect an occupant and objects on the seat by weight. For example, if a child is in the front passenger seat, the Advanced

Air Bag System is designed to turn the passenger air bag OFF in accordance with the regulations. Also, if a child restraint of the type specified in the regulations is on the seat, its weight and the child's weight can be detected and cause the air bag to turn OFF.

Front passenger seat adult occupants who are properly seated and using the seat belt as outlined in this manual should not cause the passenger air bag and front passenger knee air bag to be automatically turned OFF. For small adults it may be turned OFF, however, if the occupant takes his/her weight off the seat cushion (for example, by not sitting upright, by sitting on an edge of the seat, or by otherwise being out of position), this could cause the sensors to turn the air bag OFF. Always be sure to be seated and wearing the seat belt properly for the most effective protection by the seat belt and supplemental air bag.

NISSAN recommends that pre-teens and children be properly restrained in a rear seat. NISSAN also recommends that appropriate child restraints and booster seats be properly installed in a rear seat. If this is not possible, the occupant classification sensors are designed to operate as described above to turn the front passenger air bag and front pas-

senger knee air bag OFF for specified child restraints as required by the regulations. Failing to properly secure child restraints and to use the Automatic Locking Retractor (ALR) mode (child restraint mode) may allow the restraint to tip or move in an accident or sudden stop. This can also result in the passenger air bag and front passenger knee air bag inflating in a crash instead of being OFF. (See “Child restraints” (P.1-26) for proper use and installation.)

If the front passenger seat is not occupied, the passenger air bag and front passenger knee air bag are designed not to inflate in a crash. However, heavy objects placed on the seat could result in air bag inflation, because of the object's weight detected by the occupant classification sensors. Other conditions could also result in air bag inflation, such as if a child is standing on the seat, or if two children are on the seat, contrary to the instructions in this manual. Always be sure that you and all vehicle occupants are seated and restrained properly.

Using the front passenger air bag status light, you can monitor when the front passenger air bag and front passenger knee air bag are automatically turned OFF.

If an adult occupant is in the seat but the

front passenger air bag status light is illuminated (indicating that the front passenger air bag and front passenger knee air bag are OFF), it could be that the person is a small adult, or is not sitting on the seat properly.

If a child restraint must be used in the front seat, the front passenger air bag status light may or may not be illuminated, depending on the size of the child and the type of child restraint being used. If the front passenger air bag status light is not illuminated (indicating that the air bag might inflate in a crash), it could be that the child restraint or seat belt is not being used properly. Make sure that the child restraint is installed properly, the seat belt is used properly and the occupant is positioned properly. If the front passenger air bag status light is not illuminated, reposition the occupant or child restraint in a rear seat.

If the front passenger air bag status light will not illuminate even though you believe that the child restraint, the seat belts and the occupant are properly positioned, it is recommended that you take your vehicle to a NISSAN certified ARIYA dealer. A NISSAN certified ARIYA dealer can check the system status by using a special tool. However, until you have confirmed with your dealer that your air bag is working

properly, reposition the occupant or child restraint in a rear seat.

The NISSAN Advanced Air Bag System and front passenger air bag status light will take a few seconds to register a change in the passenger seat status. This is normal system operation and does not indicate a malfunction.

If a malfunction occurs in the front passenger air bag system, the supplemental air bag warning light , located in the meters and gauges area, will illuminate (blinking or steadily lit). Have the system checked. It is recommended you visit a NISSAN certified ARIYA dealer for this service.

Normal operation:

In order for the occupant classification sensor system to classify the front passenger based on weight, please follow the precautions and steps outlined below:

Precautions:

- Make sure that there are no objects weighing over 9.1 lbs (4 kg) hanging on the seat or placed in the seatback pocket.
- Make sure that a child restraint or other object is not pressing against the rear of the seatback.

- Make sure that a rear passenger is not pushing or pulling on the back of the front passenger seat.
- Make sure that the front passenger seat or seatback is not forced back against an object on the seat or floor behind it.
- Make sure that there is no object placed under the front passenger seat.
- Make sure that the front passenger seat head restraint does not contact the roof when adjusting the front passenger seat.

Steps:

1. Adjust the seat as outlined. (See “Seats” (P.1-3).) Sit upright, leaning against the seatback, and centered on the seat cushion with your feet comfortably extended to the floor.
2. Make sure there are no objects on your lap.
3. Fasten the seat belt as outlined. (See “Seat belts” (P.1-14).) Front passenger seat belt buckle status is monitored by the occupant classification system, and is used as an input to determine occupancy status. So, it is highly recommended that the front passenger fasten their seat belt.

4. Remain in this position for 30 seconds allowing the system to classify the front passenger before the vehicle is put into motion.
5. Ensure proper classification by checking the front passenger air bag status light.

NOTE:

This vehicle's occupant classification sensor system generally keeps the classification locked during driving, so it is important that you confirm that the front passenger is properly classified prior to driving. However, the occupant classification sensor system may recalculate the weight of the occupant under some conditions (both while driving and when stopped), so the front passenger seat occupant should continue to remain seated as outlined above.

Troubleshooting:

If you think the front passenger air bag status light is incorrect:

1. If the light is ON with an adult occupying the front passenger seat:
 - Occupant is a small adult — the front passenger air bag status light is functioning as intended. The front passenger air bag and front passenger knee air bag are suppressed.

However, if the occupant is not a small

adult, then this may be due to the following conditions that may be interfering with the weight sensors:

- Occupant is not sitting upright, leaning against the seatback, and centered on the seat cushion with his/her feet comfortably extended to the floor.
- A child restraint or other object pressing against the rear of the seatback.
- A rear passenger pushing or pulling on the back of the front passenger seat.
- Forcing the front seat or seatback against an object on the seat or floor behind it.
- An object placed under the front passenger seat.
- An object placed between the seat cushion and center console or between the seat cushion and the door.

If the vehicle is moving, please come to a stop when it is safe to do so. Check and correct any of the above conditions. Restart the vehicle and wait 1 minute.

NOTE:

A system check will be performed during which the front passenger air bag status light will remain lit for about 7 seconds initially.

If the light is still ON after this, the person

should be advised not to ride in the front passenger seat and the vehicle should be checked as soon as possible. It is recommended you visit a NISSAN certified ARIYA dealer for this service.

2. If the light is OFF with a small adult, child or child restraint occupying the front passenger seat.

This may be due to the following conditions that may be interfering with the weight sensors:

 - Small adult or child is not sitting upright, leaning against the seatback, and centered on the seat cushion with his/her feet comfortably extended to the floor.
 - The child restraint is not properly installed, as outlined. (See "Child restraints" (P.1-26).)
 - An object weighing over 9.1 lbs (4 kg) hanging on the seat or placed in the seatback pocket.
 - A child restraint or other object pressing against the rear of the seatback.
 - A rear passenger pushing or pulling on the back of the front passenger seat.
 - Forcing the front seat or seatback against an object on the seat or floor behind it.

- An object placed under the front passenger seat.
- An object placed between the seat cushion and center console.
- The front passenger seat head restraint contacting the roof.

If the vehicle is moving, please come to a stop when it is safe to do so. Check and correct any of the above conditions. Restart the vehicle and wait 1 minute.

NOTE:

A system check will be performed during which the front passenger air bag status light will remain lit for about 7 seconds initially.

If the light is still OFF after this, the small adult, child or child restraint should be repositioned in the rear seat and it is recommended that the vehicle should be checked by a NISSAN certified ARIYA dealer as soon as possible.

3. If the light is OFF with no front passenger and no objects on the front passenger seat, the vehicle should be checked as soon as possible. It is recommended you visit a NISSAN certified ARIYA dealer for this service.

Other supplemental front-impact air bag precautions



WARNING

- Do not place any objects on the steering wheel pad or on the instrument panel. Also, do not place any objects between any occupant and the steering wheel or instrument panel. Such objects may become dangerous projectiles and cause injury if the front air bags inflate.
- Do not place objects with sharp edges on the seat. Also, do not place heavy objects on the seat that will leave permanent impressions in the seat. Such objects can damage the seat or occupant classification sensors (weight sensors). This can affect the operation of the air bag system and result in serious personal injury.
- Do not use water or acidic cleaners (hot steam cleaners) on the seat. This can damage the seat or occupant classification sensors. This can also affect the operation of the air bag system and result in serious personal injury.

- Immediately after inflation, several front air bag system components will be hot. Do not touch them; you may severely burn yourself.
- No unauthorized changes should be made to any components or wiring of the supplemental air bag system. This is to prevent accidental inflation of the supplemental air bag or damage to the supplemental air bag system.
- Do not make unauthorized changes to your vehicle's electrical system, suspension system or front end structure. This could affect proper operation of the front air bag system.
- Tampering with the front air bag system may result in serious personal injury. Tampering includes changes to the steering wheel and the instrument panel assembly by placing material over the steering wheel pad and above the instrument panel or by installing additional trim material around the air bag system.
- Removing or modifying the front passenger seat may affect the function of the air bag system

and result in serious personal injury.

- Modifying or tampering with the front passenger seat may result in serious personal injury. For example, do not change the front seats by placing material on the seat cushion or by installing additional trim material, such as seat covers, on the seat that is not specifically designed to assure proper air bag operation. Additionally, do not stow any objects under the front passenger seat or the seat cushion and seatback. Such objects may interfere with the proper operation of the occupant classification sensors.
- No unauthorized changes should be made to any components or wiring of the seat belt system. This may affect the front air bag system. Tampering with the seat belt system may result in serious personal injury.
- It is recommended you visit a NISSAN certified ARIYA dealer for work on and around the front air bag. It is also recommended you visit a NISSAN certified ARIYA dealer for installation of electrical

equipment. The Supplemental Restraint System (SRS) wiring harnesses* should not be modified or disconnected. Unauthorized electrical test equipment and probing devices should not be used on the air bag system.

- A cracked windshield should be replaced immediately by a qualified repair facility. A cracked windshield could affect the function of the supplemental air bag system.

*The SRS wiring harness connectors are yellow and orange for easy identification.

When selling your vehicle, we request that you inform the buyer about the front air bag system and guide the buyer to the appropriate sections in this Owner's Manual.

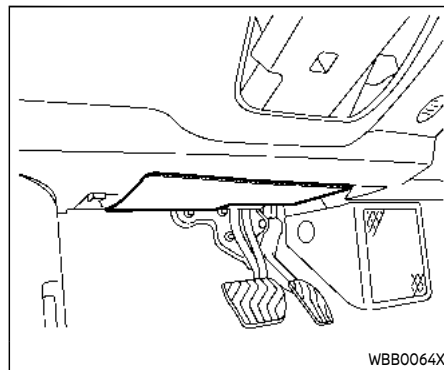

Driver's side

DRIVER AND FRONT PASSENGER SUPPLEMENTAL KNEE AIR BAG

The knee air bag is located in the knee bolster, on the driver's and front passenger's sides. **All of the information, cautions and warnings in this manual apply and must be followed.** The knee air bag is designed to inflate in higher severity frontal collisions, although it may inflate if the forces in another type of collision are similar to those of a higher severity frontal impact. It may not inflate in certain collisions.

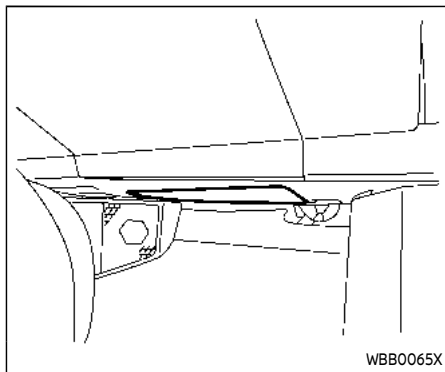

Front passenger's side

Vehicle damage (or lack of it) is not always an indication of proper knee air bag operation.

When the knee air bag inflates, a fairly loud noise may be heard, followed by release of smoke. This smoke is not harmful and does not indicate a fire. Care should be taken not to inhale it, as it may cause irritation and choking. Those with a history of a breathing condition should get fresh air promptly.

The knee air bag helps to cushion the impact force on the knees of the driver and front passenger. It can help reduce serious injuries. However, an inflating knee air bag may cause abrasions or

other injuries. The knee air bag provides restraint to the lower body.

The knee air bag inflates quickly in order to help protect the occupants. Because of this, the force of the knee air bag inflating can increase the risk of injury if the occupant is too close to, or is against, this air bag module during inflation. The knee air bag will deflate quickly after the collision is over OR the knee air bag will remain inflated for a short time.

The knee air bag operates only when the power switch is placed in the ON position.

After placing the power switch in the ON position, the supplemental air bag warning light illuminates. The supplemental air bag warning light will turn off after about 7 seconds if the system is operational.



WARNING

- **Do not place any objects between the knee bolster and the driver's or front passenger's seat. Such objects may become dangerous projectiles and cause injury if a knee air bag inflates.**

- **Right after inflation, the knee air bag system components will be hot. Do not touch them; you may severely burn yourself.**
- **No unauthorized changes should be made to any components or wiring of the knee air bag system. This is to prevent damage to or accidental inflation of the knee air bag system.**
- **Do not make unauthorized changes to your vehicle's electrical system or suspension system. This could affect proper operation of the knee air bag system.**
- **Tampering with the knee air bag system may result in serious personal injury. For example, do not change the driver or front passenger knee bolster or install additional trim material around the knee air bag.**
- **It is recommended that you visit a NISSAN certified ARIYA dealer for work on and around the knee air bag. It is also recommended that you visit a NISSAN certified ARIYA dealer for installation of electrical equipment. The SRS wiring harnesses* should not be modified or disconnected. Unauthorized elec-**

trical test equipment and probing devices should not be used on the knee air bag system.

***The SRS wiring harness or connectors are yellow or orange for easy identification.**

When selling your vehicle, we request that you inform the buyer about the knee air bag system and guide the buyer to the appropriate sections in this manual.

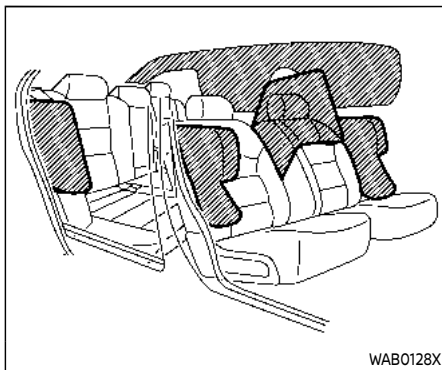

FRONT, FRONT CENTRAL*, REAR OUTBOARD SEAT-MOUNTED SIDE-IMPACT SUPPLEMENTAL AIR BAG AND ROOF-MOUNTED CURTAIN SIDE-IMPACT AND ROLLOVER SUPPLEMENTAL AIR BAG SYSTEMS

*: if so equipped

The side air bags are located in the outside of the seatback of the front and rear seats. The front central side air bag (if so equipped) is located in the inside of the seatback of the driver's seat. The curtain air bags are located in the side roof rails. **All of the information, cautions and warnings in this manual apply and must**

be followed. The side air bags and curtain air bags are designed to inflate in higher severity side collisions, although they may inflate if the forces in another type of collision are similar to those of a higher severity side impact. They are designed to inflate on the side where the vehicle is impacted. They may not inflate in certain side collisions.

Curtain air bags are also designed to inflate in certain types of rollover collisions or near rollovers. As a result, certain vehicle movements (for example, during severe off-roading) may cause the curtain air bags to inflate.

Vehicle damage (or lack of it) is not always an indication of proper side air bag and curtain air bag operation.

When the side air bags and curtain air bags inflate, a fairly loud noise may be heard, followed by release of smoke. This smoke is not harmful and does not indicate a fire. Care should be taken not to inhale it, as it may cause irritation and choking. Those with a history of a breathing condition should get fresh air promptly.

Side air bags, along with the use of seat belts, help to cushion the impact force on the chest and pelvic area of the front and rear outboard occupants. Front central side air bag, along with the use of seat

belts, helps to cushion the impact force on the head area of the front occupants. Curtain air bags help to cushion the impact force to the head area of occupants in the front and rear outboard seating positions. They can help save lives and reduce serious injuries. However, an inflating side air bag or curtain air bag may cause abrasions or other injuries. Side air bags and curtain air bags do not provide restraint to the lower body.

The seat belts should be correctly worn and the driver, front passenger and rear outboard occupants seated upright as far as practical away from the side air bags. Rear seat passengers should be seated as far away as practical from the door finishers and side roof rails. The side air bags and curtain air bags inflate quickly in order to help protect the occupants. Because of this, the force of the side air bags and curtain air bags inflating can increase the risk of injury if the occupant is too close to, or is against, these air bag modules during inflation. The side air bags will deflate quickly after the collision is over. The front central side air bag and curtain air bags will remain inflated for a short time.

The side air bags and curtain air bags operate only when the power switch is in the ON position.

After placing the power switch in the ON position, the supplemental air bag warning light illuminates. The supplemental air bag warning light will turn off after about 7 seconds if the systems are operational.



WARNING

- Do not place any objects near the seatback of the front and rear seats. Also, do not place any objects (an umbrella, bag, etc.) between the front and rear door finisher, the center console, and the front and rear seats. Such objects may become dangerous projectiles and cause injury if a side air bag inflates.
- Right after inflation, several side air bag and curtain air bag system components will be hot. Do not touch them; you may severely burn yourself.
- No unauthorized changes should be made to any components or wiring of the side air bag and curtain air bag systems. This is to prevent damage to or accidental inflation of the side air bag and curtain air bag systems.

- Do not make unauthorized changes to your vehicle's electrical system, suspension system or side panel. This could affect proper operation of the side air bag and curtain air bag systems.
- Tampering with the side air bag system may result in serious personal injury. For example, do not change the front and rear seats by placing material near the seatbacks or by installing additional trim material, such as seat covers, around the side air bag.
- Removing or modifying the front and rear passenger seat may affect the function of the air bag system and result in serious personal injury.
- It is recommended you visit a NISSAN certified ARIYA dealer for work on and around the side air bag and curtain air bag. It is also recommended you visit a NISSAN certified ARIYA dealer for installation of electrical equipment. The Supplemental Restraint System (SRS) wiring harnesses* should not be modified or disconnected. Unauthorized electrical test equipment and probing devices should not be used on the side air

bag or curtain air bag systems.

***The SRS wiring harness connectors are yellow and orange for easy identification.**

When selling your vehicle, we request that you inform the buyer about the side air bag and curtain air bag systems and guide the buyer to the appropriate sections in this Owner's Manual.

SEAT BELTS WITH PRETENSIONERS (front and rear outboard seats)



WARNING

- **The pretensioners cannot be re-used after activation. They must be replaced together with the retractor and buckle as a unit.**
- **If the vehicle becomes involved in a collision but a pretensioner is not activated, be sure to have the pretensioner system checked and, if necessary, repaired. It is recommended you visit a NISSAN certified ARIYA dealer for this service.**
- **No unauthorized changes should be made to any components or wiring of the pretensioner system. This is to prevent damage to or accidental activation of the pretensioners. Tampering with the pretensioner system may result in serious personal injury.**
- **It is recommended you visit a NISSAN certified ARIYA dealer for work on and around the pretensioner system. It is also recommended you visit a NISSAN certified ARIYA dealer for installa-**

tion of electrical equipment. Unauthorized electrical test equipment and probing devices should not be used on the pretensioner system.

- **If you need to dispose of a pretensioner or scrap the vehicle, it is recommended you visit a NISSAN certified ARIYA dealer for this service. Correct pretensioner disposal procedures are set forth in the appropriate NISSAN Service Manual. Incorrect disposal procedures could cause personal injury.**

The pretensioner system may activate with the supplemental air bag system in certain types of collisions. Working with the seat belt retractor, it helps tighten the seat belt when the vehicle becomes involved in certain types of collisions, helping to restrain front and rear outboard seat occupants.

The pretensioner is encased with the seat belt retractor. These seat belts are used the same way as conventional seat belts.

When a pretensioner activates, smoke is released and a loud noise may be heard. The smoke is not harmful and does not indicate a fire. Care should be taken not to inhale it, as it may cause irritation and

choking. Those with a history of a breathing condition should get fresh air promptly.

After pretensioner activation, load limiters allow the seat belt to release webbing (if necessary) to reduce forces against the chest.

The supplemental air bag warning light  is used to indicate malfunctions in the pretensioner system. See "Supplemental air bag warning light" (P.1-69). If the operation of the supplemental air bag warning light indicates there is a malfunction, have the system checked. It is recommended you visit a NISSAN certified ARIYA dealer for this service.

When selling your vehicle, we request that you inform the buyer about the pretensioner system and guide the buyer to the appropriate sections in this Owner's Manual.

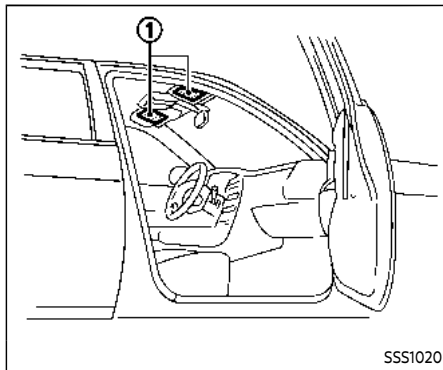

SUPPLEMENTAL AIR BAG WARNING LABELS

Warning labels about the supplemental front-impact air bag system are placed in the vehicle as shown in the illustration.

① SRS air bag

The warning labels are located on the surface of the sun visors.



WARNING

Do not use a rear-facing child restraint on a seat protected by an air bag in front of it. If the air bag

deploys, it may cause serious injury or death.



SUPPLEMENTAL AIR BAG WARNING LIGHT

The supplemental air bag warning light, displaying  in the instrument panel, monitors the circuits for the air bag systems, pretensioners and all related wiring.

When the power switch is in the ON position, the supplemental air bag warning light illuminates for about 7 seconds and then turns off. This means the system is operational.

If any of the following conditions occur, the air bag and/or pretensioner systems need servicing:

- The supplemental air bag warning light remains on after approximately 7 seconds.
- The supplemental air bag warning light flashes intermittently.
- The supplemental air bag warning light does not come on at all.

Under these conditions, the air bag and/or pretensioner systems may not operate properly. They must be checked and repaired. It is recommended you visit a NISSAN certified ARIYA dealer for this service.



WARNING

If the supplemental air bag warning light is on, it could mean that the front air bag, knee air bag, side air bag, curtain air bag and/or pretensioner systems will not operate in an accident. To help avoid injury to yourself or others, have your vehicle checked as soon as possible. It is recommended you visit a NISSAN certified ARIYA dealer for this service.

REPAIR AND REPLACEMENT PROCEDURE

The front air bags, knee air bags, side air bags, curtain air bags and pretensioners are designed to activate on a one-time-only basis. As a reminder, unless it is damaged, the supplemental air bag warning light will remain illuminated after inflation has occurred. These systems should be repaired and/or replaced as soon as possible. It is recommended you visit a NISSAN certified ARIYA dealer for this service.

When maintenance work is required on the vehicle, the front air bags, knee air bags, side air bags, curtain air bags and pretensioners and related parts should be pointed out to the person performing the maintenance. The power switch should always be in the OFF position when working under the hood or inside the vehicle.



WARNING

- **Once a front air bag, knee air bag, side air bag or curtain air bag has inflated, the air bag module will not function again and must be replaced. Additionally, the activated pretensioners must also**

be replaced. The air bag module and pretensioner should be replaced. It is recommended you visit a NISSAN certified ARIYA dealer for this service. However, the air bag modules and pretensioner system cannot be repaired.

- The front air bag, knee air bag, side air bag and curtain air bag systems, and pretensioner system should be inspected if there is any damage to the front end or side portion of the vehicle. It is recommended you visit a NISSAN certified ARIYA dealer for this service.
- If you need to dispose of a supplemental air bag or pretensioner or scrap the vehicle, it is recommended you visit a NISSAN certified ARIYA dealer. Correct supplemental air bag and pretensioner system disposal procedures are set forth in the appropriate NISSAN Service Manual. Incorrect disposal procedures could cause personal injury.
- If there is an impact to your vehicle from any direction, your Occupant Classification Sensor (OCS) should be checked to verify

it is still functioning correctly. It is recommended that you visit a NISSAN certified ARIYA dealer for this service. The OCS should be checked even if no air bags deploy as a result of the impact. Failure to verify proper OCS function may result in an improper air bag deployment resulting in injury or death.

2 Instruments and controls

Cockpit	2-3	Settings	2-25
Instrument panel	2-4	Vehicle information display warnings and indicators	2-34
Meters and gauges	2-5	Trip computer	2-45
Changing the meter screen view	2-6	Charging status display	2-48
Speedometer and odometer	2-7	Timer display	2-49
Power meter	2-7	ECO Drive Report	2-49
Li-ion battery available charge gauge	2-8	Clock and outside air temperature	2-50
Driving range	2-9	Head Up Display (HUD) (if so equipped)	2-51
Instrument brightness control	2-10	How to use the HUD	2-53
Shift position indicator	2-10	Driver Assistance/Navigation/Traffic Sign/ Audio/TEL/SMS/Message for Driver Assistance linking	2-54
e-Step indicator	2-10	Warning message (if so equipped)	2-54
Warning lights, indicator lights and audible reminders	2-11	Security systems	2-55
Checking lights	2-12	Vehicle Security System	2-55
Warning/indicator lights (red)	2-12	NISSAN Vehicle Immobilizer System	2-55
Warning/indicator lights (yellow)	2-15	Wiper and washer switch	2-56
Warning/indicator lights (other)	2-20	Windshield wiper and washer operation	2-57
Audible reminders	2-21	Rain-sensing auto wiper system (if so equipped)	2-58
Vehicle information display	2-22	Rear window wiper and washer operation	2-59
How to use the vehicle information display	2-23	Rear window and outside mirror defroster switch	2-60
Swiping the navigation screen	2-23		
Shortcut Menu	2-23		
Startup display	2-24		
Personal Display	2-24		

Headlight and turn signal switch	2-61	Sunglasses holder	2-87
Headlight switch	2-61	Card holder	2-88
Headlight aiming control	2-67	Coat hooks	2-88
Turn signal switch	2-68	Cargo cover (if so equipped)	2-89
Fog light switch (if so equipped)	2-69	Luggage hooks	2-90
Emblem light	2-69	Roof rack (if so equipped)	2-90
Horn	2-69	Windows	2-91
Heated steering wheel (if so equipped)	2-70	Power windows	2-91
Heated seats (if so equipped)	2-70	Moonroof (if so equipped)	2-95
Operation with touch screen display	2-72	Automatic moonroof and sunshade	2-95
Operation with switch (for rear outboard seats)	2-72	Interior lights	2-97
Climate controlled seats (if so equipped)	2-73	Interior light switch	2-98
Steering Assist switch	2-75	Map lights	2-98
Rear Door Alert	2-75	Rear personal lights	2-98
Power outlets	2-77	Vanity mirror light	2-99
USB (Universal Serial Bus) charging connector	2-77	Cargo light	2-99
Wireless charger (if so equipped)	2-78	HomeLink® Universal Transceiver (if so equipped)	2-99
Emergency Call (SOS) button	2-80	Programming HomeLink®	2-100
Emergency support	2-80	Programming HomeLink® for Canadian customers and gate openers	2-101
Storage	2-82	Operating the HomeLink® Universal Transceiver	2-102
Cup holders	2-82	Programming troubleshooting	2-102
Soft bottle holders	2-83	Clearing the programmed information	2-102
Adjustable luggage floor	2-83	Reprogramming a single HomeLink® button	2-102
Glove box	2-84	If your vehicle is stolen	2-103
Console box	2-85		
Flexible center storage	2-86		

COCKPIT

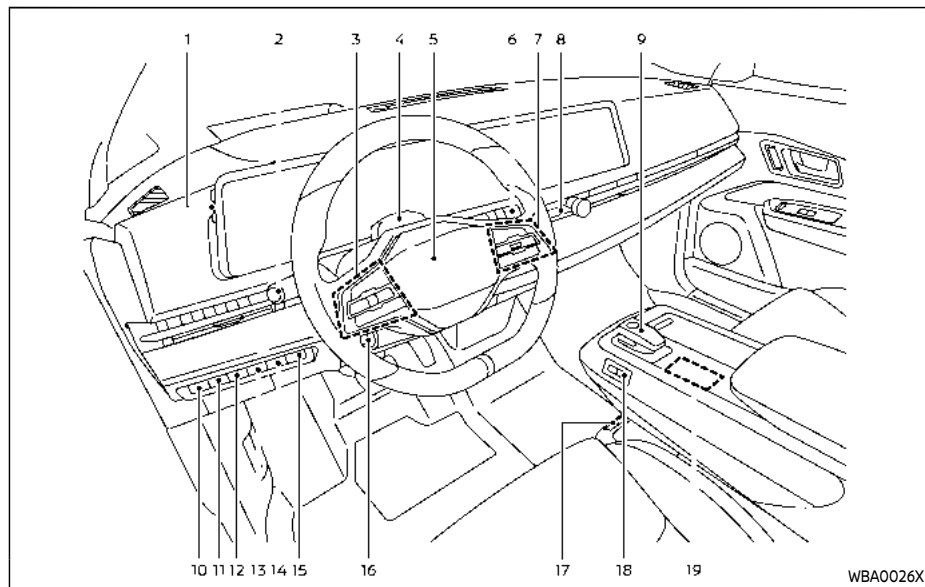

1. Instrument brightness control
2. Headlight and turn signal switch
3. Steering-wheel-mounted controls (left side)
 - Audio control**
 - Vehicle information display control
4. Driver monitor camera
5. Steering wheel
 - Horn
6. Wiper and washer switch
7. Steering-wheel-mounted controls (right side)
 - ProPILOT Assist switch
 - Bluetooth® Hands-Free Phone System

- switches**
- Voice Recognition system switch**
 - Siri® Eyes Free**
8. Hazard indicator flasher switch
 9. Shift lever/Park button
 10. Headlight aiming control switch
 11. Steering Assist switch
 12. Head Up Display (HUD) switch*
 13. Automatic brake hold switch
 14. Immediate charge switch
 15. Power liftgate switch*
 16. Tilt and telescopic steering wheel control
 17. Power outlet
 - USB (Universal Serial Bus) connection ports**
 18. Power sliding armrest switch*
 19. Haptic switches
 - Drive Mode Selector
 - e-Step switch
 - ProPILOT Park switch*
 - Flexible center storage switch*
- *: if so equipped
**: See the separate NissanConnect® Owner's Manual.

INSTRUMENT PANEL

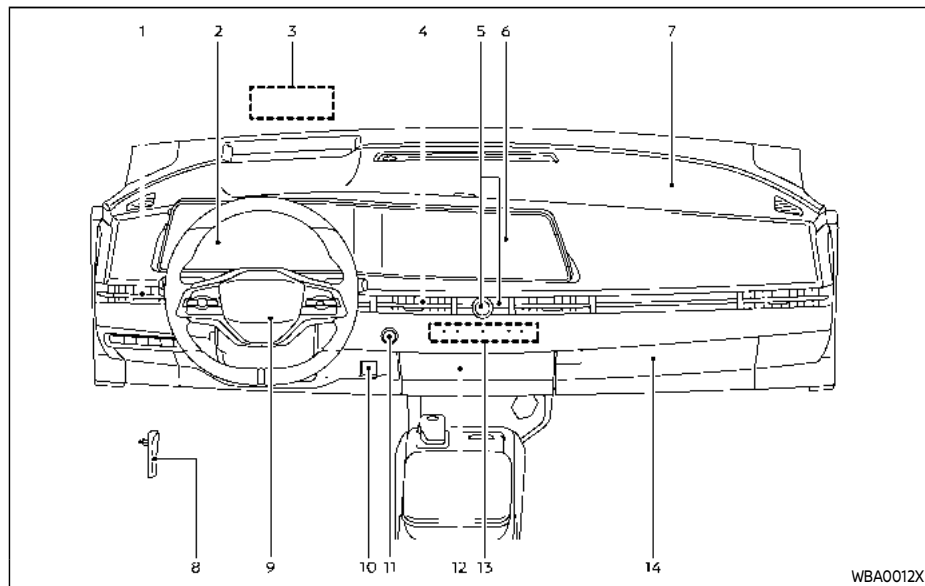

1. Side ventilator
2. Meters and gauges/vehicle information display/Clock
3. Head Up Display (HUD)*
4. Center ventilator
5. Audio switches**
6. Touch screen display

- Audio system** or navigation system**
- RearView Monitor*
- Intelligent Around View® Monitor*
- Bluetooth® Hands-Free Phone System**
- Heater and air conditioner control display

- Heated seat*
- Climate controlled seat*
- Heated steering wheel*

7. Front passenger supplemental air bag
8. Hood release handle
9. Driver supplemental front-impact air bag
10. Parking brake switch
11. Push-button power switch
12. Flexible center storage
13. Heater and air conditioner control
 - Rear window and outside mirror defroster switch
14. Glove box

*: if so equipped

** : See the separate NissanConnect® Owner's Manual.

METERS AND GAUGES

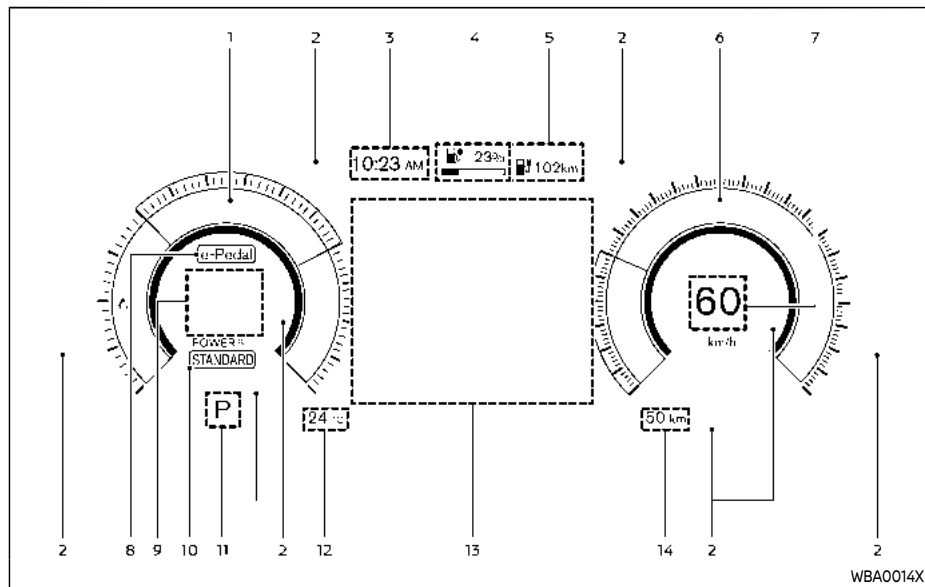

The view of the meter screen can be changed. (See “Changing the meter screen view” (P.2-6).)

- For cleaning, use a soft cloth, dampened with water. Never use a rough cloth, alcohol, benzene, thinner or any kind of solvent or paper towel with a chemical cleaning agent. They will scratch or cause discoloration to the lens.
- Do not spray any liquid such as water on the meter lens. Spraying liquid may cause the system to malfunction.

- | | |
|--|-----------------------------------|
| 1. Power meter | 8. e-Step indicator |
| 2. Warning and indicator lights | 9. Personal display |
| 3. Clock | 10. Drive Mode Selector indicator |
| 4. Li-ion battery available charge gauge | 11. Shift position indicator |
| 5. Driving range | 12. Outside air temperature |
| 6. Speedometer | 13. Vehicle information display |
| 7. Vehicle speed | 14. Odometer |

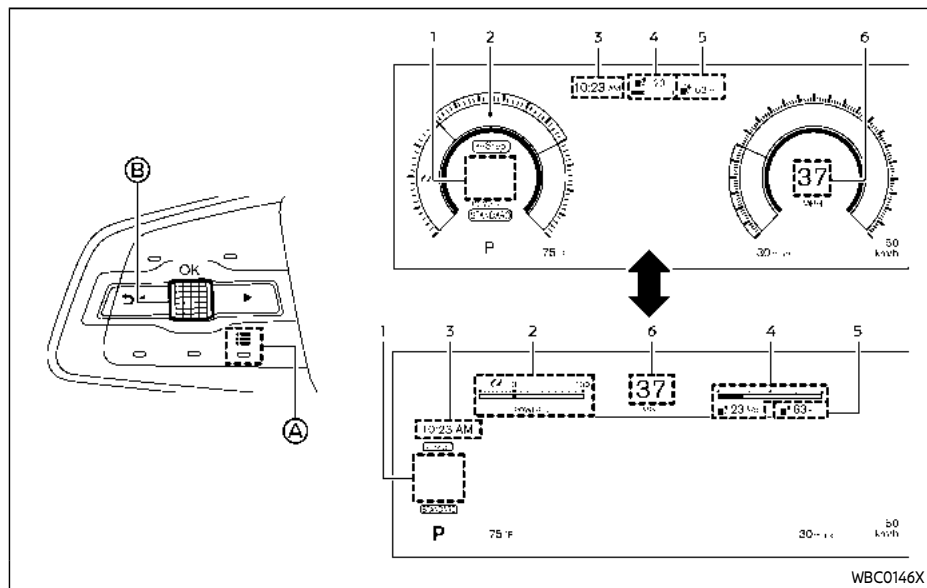

To change the meter screen view:

1. Push the control switch **A** on the left side of the steering wheel.

“Shortcut Menu” appears on the vehicle information display area.

2. Select “Change Meter View” by rotating the scroll dial **B** and push it to change the view.

1. Personal display
2. Power meter
3. Clock
4. Li-ion battery available charge gauge
5. Driving range
6. Vehicle speed

CHANGING THE METER SCREEN VIEW

The meter screen view can be changed to expand the vehicle information display area.

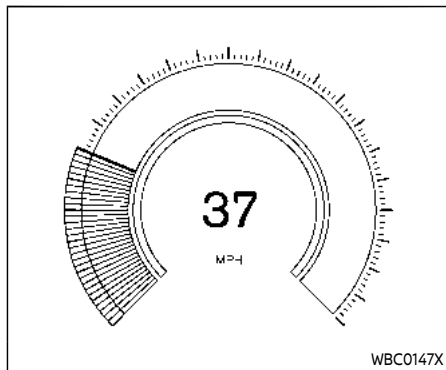

SPEEDOMETER AND ODOMETER

Speedometer

The speedometer indicates vehicle speed (MPH or km/h).

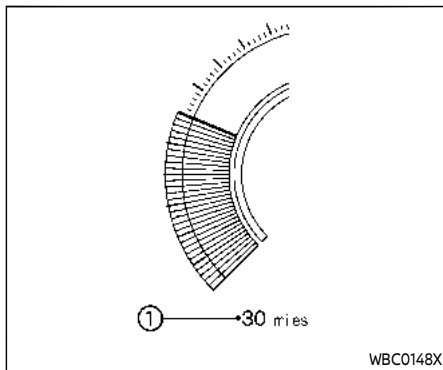

Odometer

The odometer ① is displayed in the vehicle information display:

- when the power switch is in the ON or READY to drive position
- for a period of time after the power switch was placed in the OFF position

The odometer displays the total distance the vehicle has been driven.

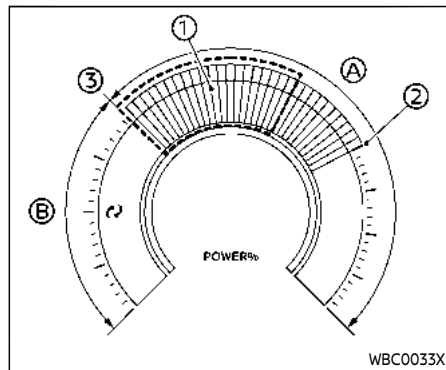

POWER METER

The power meter displays the traction motor power level when the accelerator pedal is depressed, as well as the level of power regeneration provided to the Li-ion battery by the regenerative brake.

This meter displays the actual traction motor power consumption (A) and the regenerative brake power provided to the Li-ion battery (B). The white illuminated part (1) in the display moves right or left depending on demand.

The power meter is in a neutral state (3).

The white illuminated part moves to the right when power is provided to the traction motor (Li-ion battery discharges).

The white illuminated part moves to the left when power is generated and provided to the Li-ion battery by the regenerative brake system (Li-ion battery charging).

The power meter also indicates if the power provided to the motor is limited. When power is limited, a guidance line of the limitation ② is displayed.

Regenerative braking is automatically reduced when the Li-ion battery is fully charged to prevent the Li-ion battery from becoming overcharged. Regenerative braking is also automatically reduced when the Li-ion battery temperature is high/low to prevent Li-ion battery damage.

If the Li-ion battery charge is low, power provided to the traction motor is reduced. Motor output is also limited if the Li-ion battery temperature is high/low.

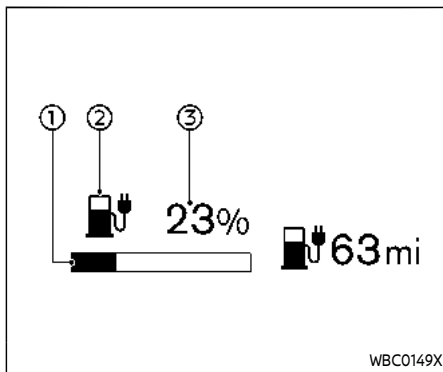

- ① The gauge indicates the approximate remaining Li-ion battery charge available to drive the vehicle.
- ② Low battery charge warning light illuminates in yellow when the available Li-ion battery charge is getting low.
- ③ This figure shows the current state of charge (%) of the Li-ion battery.

LI-ION BATTERY AVAILABLE CHARGE GAUGE

Charge the Li-ion battery before the percentage figure becomes "0".

When the low battery charge warning light  illuminates in yellow, charge as soon as it is convenient, preferably before the percentage figure becomes "0". When

the percentage figure becomes "0" and the low battery charge warning light (yellow) illuminates, there is a very small reserve of Li-ion battery charge remaining.

NOTE:

- **The length of the bar of the gauge is determined by the available charge and the amount of charge the Li-ion battery is capable of storing at the current temperature.**
- **Temperature affects the amount of charge the Li-ion battery is capable of storing. The Li-ion battery is capable of storing less power when the Li-ion battery temperature is cold. The Li-ion battery is capable of storing more power when the Li-ion battery is warm. The length of the bar of the gauge can change based on the amount of power the Li-ion battery is capable of storing. For example, when the Li-ion battery becomes colder, a longer bar is shown because the available charge is a greater percentage of the Li-ion battery's capability of storing power. When the Li-ion battery becomes warmer, a shorter bar is shown because the remaining energy is a lower percentage of the Li-ion battery's capability of storing power.**

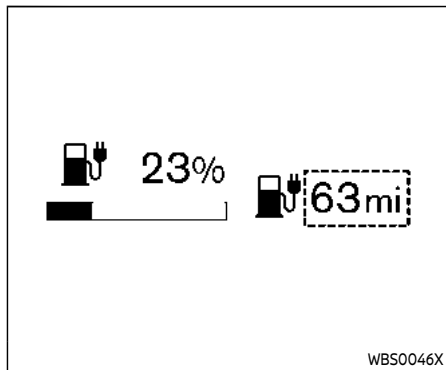

DRIVING RANGE

The driving range (miles or km) provides an estimated distance that the vehicle can be driven before recharging is necessary. The driving range is constantly being calculated, based on the amount of available Li-ion battery charge and the actual power consumption average.

The displayed driving range is the distance calculated based on the current driving style.

NOTE:

- If you continue to drive the vehicle after the low battery charge warning light (yellow) illuminates and the Li-ion battery is close to being com-

pletely discharged, “---” will be displayed. Charge the Li-ion battery as soon as possible. When the Li-ion battery is charged, the original display will be restored.

- After the Li-ion battery is charged, the displayed driving range is calculated based on the actual average energy consumption of previous journeys. The displayed driving range will vary every time the Li-ion battery is fully charged.
- The driving range will increase or decrease based on driving.

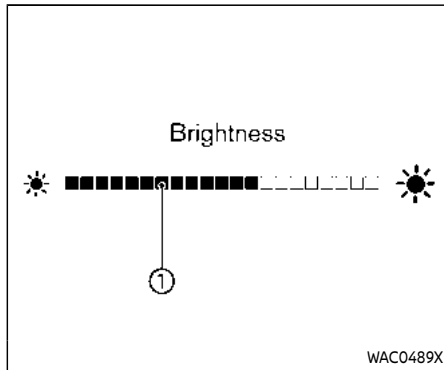
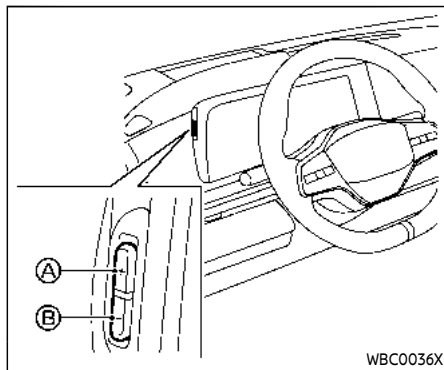

INSTRUMENT BRIGHTNESS CONTROL

The instrument brightness control switch can be operated when the power switch is in the ON position. When the switch is operated, the vehicle information display switches to the brightness adjustment mode.

Push the + switch (A) to brighten the instrument panel lights. The bar (1) moves to the right side.

Push the - switch (B) to dim the lights. The bar (1) moves to the left side.

The vehicle information display returns to the normal display when the instrument brightness control switch is not operated for more than 5 seconds.

SHIFT POSITION INDICATOR

































The shift position indicator indicates the shift position when the power switch is in the ON or READY to drive position. (See "17. Shift position indicator" (P.2-36).)

e-Step INDICATOR

The e-Step indicator in the vehicle information display shows the status of the e-Step system. When the e-Step system is turned on, the indicator is blue and displays "e-Step". When the e-Step system is turned off, the indicator changes to gray and displays "e-Step OFF".

For additional information, see "e-Step system" (P.5-21).

WARNING LIGHTS, INDICATOR LIGHTS AND AUDIBLE REMINDERS

Warning/indicator lights (red)	Warning/indicator lights (yellow)	Warning/indicator lights (other)
 12-volt battery charge warning light	 ABS Anti-lock Braking System (ABS) warning light	 Automatic brake hold indicator light (white)
 BRAKE Brake warning light (red)	 ABS OFF Automatic Emergency Braking (AEB) system OFF warning light	 Automatic brake hold indicator light (green)
 Electric shift control system warning light	 VSP OFF Approaching Vehicle Sound for Pedestrians (VSP) OFF indicator light	 Exterior light indicator
 PARK Electric parking brake warning light	 AEB OFF Automatic Emergency Braking (AEB) system OFF warning light	 Front fog light indicator light (if so equipped)
 Electronic parking brake warning light	 Brake system warning light (yellow)	 High beam assist indicator light
 Hands OFF warning light	 Electric power steering warning light	 High beam indicator light
 Master warning light	 EV system warning light	 Plug in indicator light
 Seat belt warning light and chime	 Low battery charge warning light	 Power limitation indicator light
 Supplemental air bag warning light	 Low tire pressure warning light	 READY to drive indicator light
	 Master warning light	 Turn signal/hazard indicator lights
	 RAB OFF Rear Automatic Braking (RAB) system OFF warning light	
	 Slip indicator light	
	 VDC off Vehicle Dynamic Control (VDC) off indicator light	

CHECKING LIGHTS

With all doors closed, apply the parking brake, fasten the seat belts and place the power switch in the ON position without starting the EV system. The following lights (if so equipped) will come on:



The following lights (if so equipped) come on briefly and then go off:

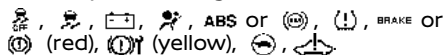

If any light does not come on or operates in a way other than described, it may indicate a burned-out bulb and/or a system malfunction. It is recommended you have the system checked by a NISSAN certified ARIYA dealer.

WARNING/INDICATOR LIGHTS (red)

See "Vehicle information display" (P.2-22).



12-volt battery charge warning light

The DC/DC converter converts 400 volt Li-ion battery voltage to charge the 12-volt battery.

When the power switch is in the ON position, the 12-volt battery charge warning light illuminates. The light will turn off when the power switch is placed in the

READY to drive position.

When this warning light illuminates, a chime sounds and the following warning lights also illuminate.

- Master warning light (red)
- EV system warning light

The following messages also appear on the vehicle information display.

If the vehicle is being driven: "Stop safely" and if the vehicle is stopped: "Apply parking brake". When these messages appear, immediately stop the vehicle in a safe location, apply the parking brake and push the park button on the shift lever to place the vehicle in the P (Park) position. The warning and the chime stop when the parking brake is operated or the vehicle is in the P (Park) position. It is recommended that you contact a NISSAN certified ARIYA dealer for support.



CAUTION

- **The DC/DC converter system may not be functioning properly if the 12-volt battery charge warning light illuminates continuously when the power switch is in the READY to drive position. Immediately stop the vehicle in a safe location and it is recommended**



that you contact a NISSAN certified ARIYA dealer.

- **If the 12-volt battery charge warning light illuminates continuously when the power switch is in the READY to drive position, do not charge the 12-volt battery. It may lead to a malfunction of the DC/DC converter system. It is recommended that you contact a NISSAN certified ARIYA dealer.**

NOTE:

- **If the vehicle does not go into the READY to drive position (when the power switch is pushed and the brake pedal is depressed), jump-start the vehicle to place the power switch in the READY to drive position. See "Jump starting" (P.6-15).**
- **Do not jump-start the vehicle and it is recommended that you contact a NISSAN certified ARIYA dealer for inspection:**
 - **If the 12-volt battery charge warning light turns off when the vehicle is in the READY to drive mode, the 12-volt battery may be discharged or there may be a malfunction in the 12-volt battery related system.**

- If the 12-volt battery charge warning light continues to illuminate when the vehicle is in the READY to drive mode, there may be a malfunction in the DC/DC converter. It is recommended that you contact a NISSAN certified ARIYA dealer for inspection.

 or  Brake warning light (red)

When the power switch is placed in the ON position or in the READY to drive position, the brake warning light remains illuminated for about a few seconds. If the brake warning light illuminates at any other time, it may indicate that the hydraulic brake system is not functioning properly. If the brake warning light illuminates, stop the vehicle immediately and it is recommended that you contact a NISSAN certified ARIYA dealer.

A buzzer sounds if a malfunction occurs in the brake system power supply.

Low brake fluid warning light:

When the power switch is placed in the ON or READY to drive position, the brake warning light illuminates, and then turns off. If the light illuminates while the power switch is in the READY to drive position with the parking brake not applied, stop

the vehicle and perform the following:

1. Check the brake fluid level. If brake fluid is necessary, add fluid and have the system checked. It is recommended you have this service performed by a NISSAN certified ARIYA dealer. (See "Brake fluid" (P.8-7).)
2. If the brake fluid level is correct, have the warning system checked. It is recommended you have this service performed by a NISSAN certified ARIYA dealer.

Anti-lock Braking System (ABS) warning indicator:

When the parking brake is released and the brake fluid level is sufficient, if both the brake warning light and the Anti-lock Braking System (ABS) warning light illuminate, it may indicate the ABS is not functioning properly. Have the brake system checked, and if necessary repaired. It is recommended you visit a NISSAN certified ARIYA dealer for this service. (See "Anti-lock Braking System (ABS) warning light" (P.2-15).)



WARNING

- Your brake system may not be working properly if the warning light is on. Driving could be dan-

gerous. If you judge it to be safe, drive carefully to the nearest service station for repairs. Otherwise, have your vehicle towed because driving it could be dangerous.

- Pressing the brake pedal with the power switch position is other than ON or READY to drive position and/or low brake fluid level may increase your stopping distance and braking will require greater pedal effort as well as pedal travel.
- If the brake fluid level is below the minimum or MIN mark on the brake fluid reservoir, do not drive until the brake system has been checked. It is recommended you visit a NISSAN certified ARIYA dealer for this service.



Electric shift control system warning light

The electric shift control system warning light illuminates when a malfunction occurs in the electric shift control system. When the master warning light illuminates, the chime sounds and the following message is displayed in the vehicle

information display: "When parked apply parking brake".

When the power switch is placed in the OFF position, the chime sounds continuously. Ensure the parking brake is applied. If the power switch cannot be placed in the OFF position, apply the parking brake and then place it in the OFF position.

Have the system checked. It is recommended that you visit a NISSAN certified ARIYA dealer.

or Electronic parking brake warning light

The electronic parking brake warning light indicates that the electronic parking brake system is operating.

When the power switch is placed in the ON position, the electronic parking brake warning light illuminates. When the EV system is started and the parking brake is released, the warning light turns off.

If the parking brake is not released, the electronic parking brake warning light remains on. Be sure that the electronic parking brake warning light has turned off before driving. (See "Parking brake" (P.5-24).)

If the electronic parking brake warning light illuminates or flashes while the brake

system warning light  illuminates, it may indicate that the electronic parking brake system is not functioning properly. Have the electronic parking brake system checked, and if necessary repaired. It is recommended that you visit a NISSAN certified ARIYA dealer promptly.

Hands OFF warning light

When the Steering Assist is activated, it monitors the driver's steering wheel operation. If the steering wheel is not operated or the driver takes his/her hands off the steering wheel for a period of time, the warning light illuminates. If the driver does not operate the steering wheel after the warning light has been illuminated, an audible alert sounds and the warning flashes in the vehicle information display, followed by a quick brake application to request the driver to take control of the vehicle again. If the driver remains unresponsive, the vehicle will automatically turn on the hazard lights and slow to a complete stop. (See "Steering Assist" (P.5-106).)

Master warning light

When the power switch is in the ON position, the master warning light illuminates if a warning message appears in the vehicle information display.

See "Vehicle information display" (P.2-22).

Seat belt warning light and chime

For driver and front passenger:

The light and chime remind you to fasten the driver and front passenger seat belts.

The light illuminates whenever the power switch is ON, and will remain illuminated until the front seat belts are fastened.

When the vehicle speed exceeds approximately 10 MPH (15 km/h), the light will blink unless the front seat belts are securely fastened.

When the power switch is ON, the chime will sound for approximately 6 seconds unless the driver's seat belt is securely fastened.

When the vehicle speed exceeds approximately 10 MPH (15 km/h), the chime will sound unless the front seat belts are securely fastened. The chime will continue to sound for approximately 95 seconds until the front seat belts are

fastened.

For rear passengers:

The seat belt warning light for the rear passengers will illuminate whenever the power switch is ON, and will remain illuminated until the rear passenger's seat belts are fastened.

For approximately 65 seconds after the power switch is ON, the system does not activate the warning light for the rear passengers.

If a rear passenger seat belt is fastened then unfastened at a vehicle speed less than approximately 10 MPH (15 km/h), the warning light will illuminate. When the vehicle speed exceeds approximately 10 MPH (15 km/h), the warning light will blink and the chime will sound.

The warning will turn off when a rear passenger seat belt is fastened or automatically turn off approximately 65 seconds after the seat belt is unfastened.

See "Seat belts" (P.1-14) and "10. Rear seat belt warning" (P.2-35).



Supplemental air bag warning light

After placing the power switch in the ON position, the supplemental air bag warning light will illuminate. The supplemental air bag warning light will turn off after about 7 seconds if the supplemental front air bag and supplemental side air bag, curtain air bag systems and/or pretensioner seat belt are operational.

If any of the following conditions occur, the front air bag, side air bag, curtain air bag and pretensioner systems need servicing.

- The supplemental air bag warning light remains on after approximately 7 seconds.
- The supplemental air bag warning light flashes intermittently.
- The supplemental air bag warning light does not illuminate at all.

It is recommended you visit a NISSAN certified ARIYA dealer for these services.

Unless checked and repaired, the Supplemental Restraint Systems and/or the pretensioners may not function properly.

For additional information, see "Supplemental Restraint System (SRS)" (P.1-48).



WARNING

If the supplemental air bag warning light is on, it could mean that the front air bag, side air bag, curtain air bag and/or pretensioner systems will not operate in an accident. To help avoid injury to yourself or others, have your vehicle checked. It is recommended you visit a NISSAN certified ARIYA dealer for this service.

WARNING/INDICATOR LIGHTS (yellow)

See "Vehicle information display" (P.2-22).



Anti-lock Braking System (ABS) warning light

When the power switch is in the ON or READY to drive position, the Anti-lock Braking System (ABS) warning light illuminates and then turns off. This indicates the ABS is operational.

If the ABS warning light illuminates while the power switch is in the READY to drive position, or while driving, it may indicate the ABS is not functioning properly. Have the system checked. It is recommended you visit a NISSAN certified ARIYA dealer for this service.

If an ABS malfunction occurs, the anti-lock function is turned off. The brake system then operates normally, but without anti-lock assistance. (See "Brake system" (P.5-152).)



Approaching Vehicle Sound for Pedestrians (VSP) OFF indicator light

If the VSP OFF indicator illuminates while the VSP system is ON, it will may indicate the VSP is not functioning properly. Have the VSP system checked. It is recommended that you visit a NISSAN certified ARIYA dealer.

See "Approaching Vehicle Sound for Pedestrians (VSP) system" (P.EV-20).



Automatic Emergency Braking (AEB) system OFF warning light

When the power switch is in the ON position, the Automatic Emergency Braking (AEB) system OFF warning light illuminates. After starting the EV system, the warning light turns off.

This light illuminates when the Automatic Emergency Braking (AEB) with Pedestrian Detection system is set to OFF on the vehicle information display.

If the light illuminates or flashes when the

Automatic Emergency Braking (AEB) with Pedestrian Detection system is ON, it may indicate that the system is unavailable. See "Automatic Emergency Braking (AEB) with Pedestrian Detection system" (P.5-120) or "Intelligent Forward Collision Warning (I-FCW)" (P.5-130).

Disabling the Vehicle Dynamic Control (VDC) system with the vehicle information display causes the Automatic Emergency Braking (AEB) with Pedestrian Detection system to become unavailable. This is not a malfunction.



Brake system warning light (yellow)

The brake system warning light functions for both the cooperative regenerative brake and the electronically driven intelligent brake systems. When the power switch is placed in the ON position or in the READY to drive position, the light remains illuminated for about a few seconds. If the light illuminates at any other time, it may indicate that the cooperative regenerative brake and/or the electronically driven intelligent brake systems are not functioning properly. Have the system checked. It is recommended that you visit a NISSAN certified ARIYA dealer. If the brake warning light (red) also illuminates, stop the vehicle

immediately and it is recommended that you contact a NISSAN certified ARIYA dealer. For additional information, see "Brakes" (P.8-9).



WARNING

- **Depressing the brake pedal when the power switch position is not in the ON or READY to drive position and/or low brake fluid level may increase the stopping distance and braking will require greater pedal effort as well as pedal travel.**
- **If the brake fluid level is below the minimum or MIN mark on the brake fluid reservoir, do not drive until the brake system has been checked. It is recommended that you visit a NISSAN certified ARIYA dealer.**
- **The cooperative regenerative brake system may not be working properly if the brake system warning light illuminates when the READY to drive indicator light is ON. If you judge it to be safe, drive carefully to the nearest service station for repairs. Otherwise, have your vehicle towed**

because driving could be dangerous.

Electric power steering warning light

When the power switch is in the ON position, the electric power steering warning light illuminates and turns off when the power switch is placed in the READY to drive position. This indicates the electric power steering is operational.

If the electric power steering warning light illuminates while the READY to drive indicator light is ON, it may indicate the electric power steering is not functioning properly and may need servicing. Have the electric power steering checked. It is recommended that you visit a NISSAN certified ARIYA dealer.

When the electric power steering warning light illuminates, the power assist to the steering will be limited or cease operation, which may cause the steering wheel operation to become heavy. Even if this occurs, the performance of the manual steering is ensured. Grip the steering wheel securely and operate it with greater force than usual.

See "Electric power steering" (P.5-151).



EV system warning light

When the power switch is in the ON position, the EV system warning light illuminates and then turns off.

This light illuminates if there is a malfunction in the following systems. It is recommended that you contact a NISSAN certified ARIYA dealer.

- Traction motor and inverter system
- Charge port or on board charger
- Li-ion battery system
- Cooling system
- Electric shift control system
- Emergency shut off system is activated. See "Emergency EV system shut off" (P.5-15).



Low battery charge warning light

The low battery charge warning light illuminates when the available Li-ion battery charge is getting low. Charge as soon as it is possible, preferably before the Li-ion battery available charge gauge reaches the bottom line.

NOTE:

The low battery charge warning light turns off immediately before the Li-ion battery is completely discharged and

the vehicle will stop. If the Li-ion battery becomes completely discharged, the vehicle must be charged in order to be driven.



Low tire pressure warning light

Your vehicle is equipped with a Tire Pressure Monitoring System (TPMS) that monitors the tire pressure of all tires.

The low tire pressure warning light warns of low tire pressure or indicates that the TPMS is not functioning properly.

After the power switch is placed in the ON position, this light illuminates for about 1 second and turns off.

Low tire pressure warning:

If the vehicle is being driven with low tire pressure, the warning light will illuminate. The "Tire Pressure Low - Add Air" warning also appears in the vehicle information display.

When the low tire pressure warning light illuminates, you should stop and adjust the tire pressure to the recommended COLD tire pressure shown on the Tire and Loading Information label. The low tire pressure warning light does not automatically turn off when the tire pressure is adjusted. After the tire is inflated to the recommended pressure, the vehicle must

be driven at speeds above 16 MPH (25 km/h) to activate the TPMS and turn off the low tire pressure warning light. Use a tire pressure gauge to check the tire pressure.

The "Tire Pressure Low - Add Air" warning is active as long as the low tire pressure warning light remains illuminated.

For additional information, see "Vehicle information display" (P.2-22), "Tire Pressure Monitoring System (TPMS)" (P.5-5) and "Tire Pressure Monitoring System (TPMS)" (P.6-3).

TPMS malfunction:

If the TPMS is not functioning properly, the low tire pressure warning light will flash for approximately 1 minute when the power switch is placed in the ON position. The light will remain on after the 1 minute. Have the system checked. It is recommended you visit a NISSAN certified ARIYA dealer for this service. The "Tire Pressure Low - Add Air" warning does not appear if the low tire pressure warning light illuminates to indicate a TPMS malfunction.

For additional information, see "Tire Pressure Monitoring System (TPMS)" (P.5-5).



WARNING

- **Radio waves could adversely affect electric medical equipment. Those who use a pacemaker should contact the electric medical equipment manufacturer for the possible influences before use.**
- **If the light does not illuminate with the power switch placed in the ON position, have the vehicle checked. It is recommended you visit a NISSAN certified ARIYA dealer for this service as soon as possible.**
- **If the light illuminates while driving, avoid sudden steering maneuvers or abrupt braking, reduce vehicle speed, pull off the road to a safe location and stop the vehicle as soon as possible. Driving with under-inflated tires may permanently damage the tires and increase the likelihood of tire failure. Serious vehicle damage could occur and may lead to an accident and could result in serious personal injury. Check the tire pressure for all four tires. Adjust the tire pressure to the**

recommended COLD tire pressure shown on the Tire and Loading Information label to turn the low tire pressure warning light OFF. If the light still illuminates while driving after adjusting the tire pressure, a tire may be flat or the TPMS may be malfunctioning. If you have a flat tire, repair it with an emergency tire puncture repair kit as soon as possible. If no tire is flat and all tires are properly inflated, it is recommended you consult a NISSAN certified ARIYA dealer.

- **Replacing tires with those not originally specified by NISSAN could affect the proper operation of the TPMS.**



CAUTION

- **The TPMS is not a substitute for the regular tire pressure check. Be sure to check the tire pressure regularly.**
- **If the vehicle is being driven at speeds of less than 16 MPH (25 km/h), the TPMS may not operate correctly.**

- **Be sure to install the specified size of tires to the four wheels correctly.**



Master warning light

When the power switch is in the ON position, the master warning light illuminates if a warning message appears in the vehicle information display.

See “Vehicle information display” (P.2-22).



Rear Automatic Braking (RAB) system OFF warning light

This light comes on when the power switch is placed in the ON position. It turns off after the EV system is started.

This light illuminates when the RAB system is turned off in the vehicle information display.

If the light illuminates when the RAB system is on, it may indicate that the system is unavailable. For additional information, see “Rear Automatic Braking (RAB)” (P.5-141).



Slip indicator light

When the power switch is in the ON position, the slip indicator light illuminates and then turns off.

The light will blink when the Vehicle Dynamic Control (VDC) system or the traction control system is operating, thus alerting the driver that the vehicle is nearing its traction limits. The road surface may be slippery.

If the light illuminates while the VDC system is on, this light alerts the driver to the fact that the VDC system's fail-safe mode is operating, for example the VDC system may not be functioning properly. Have the system checked. It is recommended you visit a NISSAN certified ARIYA dealer for this service. If a malfunction occurs in the system, the VDC system function will be canceled but the vehicle is still driveable. For additional information, see “Vehicle Dynamic Control (VDC) system” (P.5-155) of this manual.



Vehicle Dynamic Control (VDC) off indicator light

The light comes on when the VDC is turned OFF. This indicates that the VDC system and traction control system are not operating.

Turn the VDC on using the vehicle information display, or restart the EV system and the system will operate normally. (See “Vehicle Dynamic Control (VDC) system” (P.5-155).)

The light also comes on when placing the power switch in the ON position. The light will turn off after about 2 seconds if the system is operational. If the light stays on or comes on along with the  indicator light while you are driving, have the VDC system checked. It is recommended that you visit a NISSAN certified ARIYA dealer for this service.



WARNING

The VDC should remain on unless freeing a vehicle from mud or snow.

While the VDC system is operating, you might feel a slight vibration or hear the system working when starting the vehicle or accelerating, but this is not a malfunction.

WARNING/INDICATOR LIGHTS

(other)

See "Vehicle information display" (P.2-22).



Automatic brake hold indicator light (white)

The automatic brake hold indicator light (white) illuminates when the automatic brake hold system is on standby. (See "Automatic brake hold" (P.5-26).)





Automatic brake hold indicator light (green)

The automatic brake hold indicator light (green) illuminates when the automatic brake hold system is operating. (See "Automatic brake hold" (P.5-26).)



Exterior light indicator

This indicator illuminates when the headlight switch is turned to the AUTO,  or  position and the front parking lights, rear combination lights, license plate lights or headlights are on. The indicator turns off when these lights are turned off.



Front fog light indicator light (if so equipped)

The front fog light indicator light illuminates when the front fog lights are on. (See "Fog light switch" (P.2-69).)



High beam assist indicator light

The high beam assist indicator light illuminates when the high beam assist system is turned on and it is operational. (See "High beam assist" (P.2-64).)



High beam indicator light

This light illuminates when the headlight high beam is on and goes out when the low beam is selected.



Plug in indicator light

This light illuminates while charge connector is connected to the vehicle and blinks during charging.

This indicator light will not illuminate if the vehicle is in the sleep mode.

NOTE:

If the charge connector is connected to the vehicle, the power switch cannot be placed in the READY to drive position.



Power limitation indicator light

When the power switch is in the ON position, the power limitation indicator light illuminates and then turns off.

When the power limitation indicator light is illuminated with the power switch in the READY to drive position, the power provided to the traction motor is reduced. Therefore the vehicle is not as responsive when the accelerator is depressed while the power limitation indicator light is illuminated.

When this light illuminates and any message appears on the vehicle information display, follow the instructions.

This light illuminates in the following conditions.

- Li-ion battery available charge is extremely low
- Li-ion battery temperature is very low.
- When the temperature of EV system is high (motor, inverter, coolant system, Li-ion battery etc.)
- When the EV system has a malfunction.

If the low battery charge warning light is illuminated, charge the Li-ion battery as soon as possible.

If this light illuminates because the Li-ion

battery is cold due to low outside temperatures, move the vehicle to a warmer location. The Li-ion battery temperature may be increased by charging the Li-ion battery.

If the light illuminates when the EV system becomes hot due to continuous hill climbing either continue driving at a slower safe speed, or stop the vehicle in a safe location. If this light does not turn off, it is recommended that you contact a NISSAN certified ARIYA dealer.

If the light illuminates in a situation other than those described above, or if it does not turn off, there may be a system malfunction. It is recommended that you contact a NISSAN certified ARIYA dealer.



WARNING

Power limitation mode can result in reduced power and vehicle speed. The reduced speed may be lower than other traffic, which could increase the chance of a collision. Be especially careful when driving. If the vehicle cannot maintain a safe driving speed, pull to the side of the road in a safe area. Charge the Li-ion battery if the charge is low or allow the Li-ion battery to cool.

NOTE:

You can reduce charging time and keep the Li-ion battery temperature lower if you:

- **Charge more frequently in smaller amounts, and**
- **Keep the battery at a higher level of charge.**



READY to drive indicator light

The READY to drive indicator light illuminates when the EV (Electric Vehicle) system is powered and the vehicle may be driven.

The READY to drive indicator light will turn off in the following conditions.

- Certain EV (Electric Vehicle) system malfunctions.
- The READY to drive indicator light turns off immediately before the Li-ion battery is completely discharged. If the Li-ion battery becomes completely discharged, the vehicle must be charged in order to be driven. See "If the Li-ion battery becomes completely discharged" (P.6-18).



Turn signal/hazard indicator lights

The light flashes when the turn signal switch lever or hazard switch is turned on.

AUDIBLE REMINDERS

12-volt battery charge warning chime

If the 12-volt battery charge warning light illuminates, the chime will sound when a warning message is displayed on the vehicle information display.

When the chime sounds, immediately stop the vehicle in a safe location and push the park button on the shift lever and apply parking brake. The 12-volt battery charge warning light turns off and the chime will stop when the parking brake is applied or the vehicle is placed in the P (Park) position. It is recommended that you contact a NISSAN certified ARIYA dealer for support.

Brake pad wear warning

The disc brake pads have audible wear warnings. When a brake pad requires replacement, it will make a high pitched scraping sound when the vehicle is in motion. This scraping sound will first occur only when the brake pedal is depressed. After more wear of the brake

pad, the sound will always be heard even if the brake pedal is not depressed. Have the brakes checked as soon as possible if the warning sound is heard.

Electric shift control system reminder chime

If an improper shift operation is performed, for safety reasons a chime will sound and at the same time, depending on the conditions, the operation will be cancelled or the shift position will switch to the N (Neutral) position.

For more details, see “Driving the vehicle” (P.5-17).

Door lock warning chime

When the chime sounds, be sure to check both the vehicle and the Intelligent Key. See “Troubleshooting guide” (P.3-13).

Driving Aid chimes

An audible alert/chime may be heard if any of the following systems (if so equipped) are active:

- Lane Departure Warning (LDW)
- Intelligent Lane Intervention (I-LI)
- Blind Spot Warning (BSW)
- Intelligent Blind Spot Intervention (I-BSI)

- Rear Cross Traffic Alert (RCTA)
- ProPILOT Assist
- Automatic Emergency Braking (AEB) with Pedestrian Detection
- Intelligent Forward Collision Warning (I-FCW)
- Intelligent Driver Alertness (I-DA)
- Rear Automatic Braking (RAB)
- Sonar

For additional information, refer to the “5. Starting and driving” section of this manual.

Light reminder chime

The light reminder chime will sound when the headlight switch is placed in the FOG or D position after the EV system was turned off, and the driver’s door is opened with the light is on.

Turn the light switch to the OFF (if so equipped) or AUTO position when you leave the vehicle.

Power switch reminder chime

The power switch reminder chime will sound when the driver’s door is opened while the power switch is in the ON or READY to drive position. Push the power switch to the OFF position.

VEHICLE INFORMATION DISPLAY

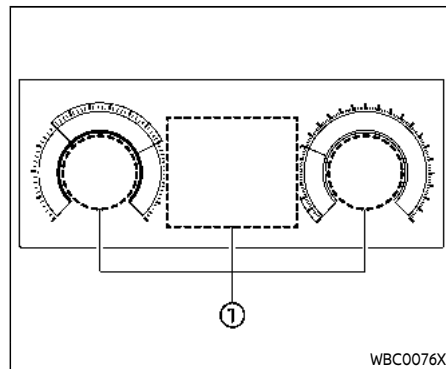

Example

The vehicle information display ① is located as shown above, and it displays the warnings and information. The following items are also displayed if the vehicle is equipped with them:

- Vehicle settings
- Trip computer information
- Driver Assistance
- ProPILOT Assist
- Intelligent Key operation information
- Audio information
- Navigation - turn by turn
- Indicators and warnings

- Tire pressure information
- Other information

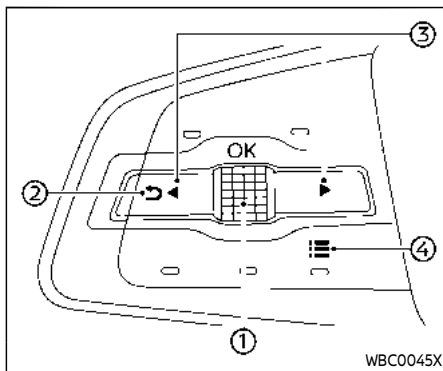

HOW TO USE THE VEHICLE INFORMATION DISPLAY

The vehicle information display can be changed using the dial/buttons located on the steering wheel.

- ① Scroll dial - navigate through the items and change or select an item in vehicle information display
this scroll dial allows up/down navigation and push to select
- ② ◀ ▶ - go back to the previous menu
- ③ ◀ ▶ - change from one display screen to the next (i.e. trip, energy economy)
- ④ ≡ - display the "Shortcut Menu" screen

SWIPING THE NAVIGATION SCREEN

You can swipe the navigation screen on the touch screen display to the vehicle information display.

See the separate NissanConnect® Owner's Manual for the navigation system.

SHORTCUT MENU

When the ≡ button ④ is pushed, the "Shortcut Menu" screen appears on the vehicle information display. Select the menu by rotating the scroll dial ① and push it.

The following menus are available:

- Change Meter View
Allows user to change the meter screen view. (See "Changing the meter screen view" (P.2-6).)
- Audio Source
Allows user to select the available audio source. (See the separate NissanConnect® Owner's Manual for the audio system.)
- Driver Assistance
Allows user to change the "Driver Assistance" settings. (See "Driver Assistance" (P.2-25).)
- Personal Display
Allows user to change the "Personal Display" settings. (See "Personal Display" (P.2-24).)

STARTUP DISPLAY

When the power switch is placed in the ON position, the vehicle information display may display the following screens if the vehicle is equipped with them:

- Home
- Blank
- Drive Computer
- Energy Economy or ECO Pedal Guide
- Energy Economy History
- Tire Pressure
- AWD Torque
- Charge Time (Est.)
- Battery Capacity
- Navigation
- Compass
- Audio
- Driver Assistance
- ProPILOT Assist
- Speed Limit Sign
- Warnings
- Settings

Warnings will only display if there are any present. For more information on warnings and indicators, see "Vehicle information display warnings and indicators" (P.2-34).

To control what items display in the vehicle information display, see "Settings" (P.2-25).

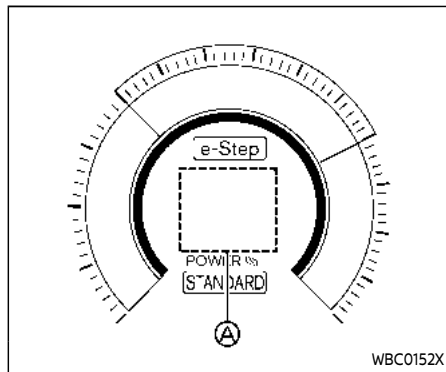

PERSONAL DISPLAY

The personal display **A** shows several information items. To select an information item:

1. Push the **≡** button **④** on the steering wheel.
2. "ShortCut Menu" screen appears on the vehicle information display.
3. Select "Personal Display" by rotating the scroll dial **①** and push the scroll dial to confirm.

The information item can be selected from below:

- Blank (nothing is displayed)

- Navigation (including compass)
- Time to Destination
- Energy Economy
- Trip
- Gear position
- Average speed
- Brake Light

The personal display will move when the meter screen view is changed. For additional information, refer to "Changing the meter screen view" (P.2-6).

SETTINGS

The setting mode allows user to change the information displayed in the vehicle information display and some settings. The following items are available if the vehicle is equipped with them:

- VDC Setting
- Driver Assistance
- Personal Display
- Head-Up Display
- ECO Mode Setting
- TPMS setting
- Clock
- Vehicle Settings
- EV Settings
- Maintenance
- Customize Display

- Unit/Language
- Factory Reset

VDC Setting

To change the setting, use the scroll dial ① to select and push it.

- System
Allows user to turn the Vehicle Dynamic Control (VDC) system ON or OFF. By default the VDC system will be turned ON. If the VDC system is turned off, the VDC OFF indicator light will illuminate.

NOTE:

The vehicle should be driven with the Vehicle Dynamic Control (VDC) system ON for most driving conditions. (See "Vehicle Dynamic Control (VDC) system" (P.5-155).)

Driver Assistance

To change the status, warnings or turn on or off any of the systems/warnings displayed in the "Driver Assistance" menu, use the scroll dial ① to select and change a menu item. The following items are available if the vehicle is equipped with them:

- Intelligent Cruise
- Lane Centering Assist

- Lane Change Assist
- Lane Assist
- Blind Spot Assist
- Emergency Assist
- Traffic Sign Assist
- Parking Assist
- Driver Monitor
- Sound Settings
- Timer Alert
- Low Temp. Alert
- Chassis Control
- e-Step

Intelligent Cruise (if so equipped):

- Speed Adjust by Route
Allows user to turn the function ON/OFF.
- Spd. Limit Assist
Allows user to turn the function ON (Manual/Auto)/OFF.
- Speed Limit Offset (for ProPILOT Assist 2.0)
Allows user to set the offset speed from -5 MPH (-10 km/h) to +5 MPH (10 km/h).

Lane Centering Assist:

- Steering Assist
Allows user to turn the function ON/OFF.

- Hands Off Mode (if so equipped)
Allows user to turn the function ON/OFF.

Lane Change Assist (if so equipped):

- Route Assist
Allows user to turn the function ON/OFF.
- Route Assist Mode
Allows user to select an item from below.
 - Once
 - Everytime
- Activate by turn signal
Allows user to turn the function ON/OFF.
- Passing Change Assist
Allows user to turn the function ON/OFF.
- Passing Setting
Allows user to select an item from below.
 - Sport
 - Standard
 - Comfort

Lane Assist:

- Warning
Allows user to turn the Lane Departure Warning (LDW) system ON/OFF.

- Intervention
Allows user to turn the Intelligent Lane Intervention (I-LI) system ON/OFF.
(See "Lane Departure Warning (LDW)" (P.5-44) and "Intelligent Lane Intervention (I-LI)" (P.5-49).)

Blind Spot Assist:

- Warning
Allows user to turn the Blind Spot Warning (BSW) system ON/OFF.
- Intervention
Allows user to turn the Intelligent Blind Spot Intervention (I-BSI) system ON/OFF.
(See "Blind Spot Warning (BSW)" (P.5-55) and "Intelligent Blind Spot Intervention (I-BSI)" (P.5-63).)

Emergency Assist:

- Emergency Braking
Allows user to turn the function ON/OFF.
- Rear Auto Braking
Allows user to turn the function ON/OFF.
(See "Automatic Emergency Braking (AEB) with Pedestrian Detection system" (P.5-120), "Intelligent Forward Collision Warning (I-FCW)" (P.5-130) and "Rear Automatic Braking (RAB)" (P.5-141).)

Traffic Sign Assist (if so equipped):

- Speed Limit Warning
Allows user to turn the function ON/OFF.
- Traffic Sign
Allows user to turn the function ON/OFF.
(See "Traffic Sign Recognition (TSR)" (P.5-40).)

Parking Assist:

- Rear Cross Traffic Alert
Allows user to turn the function ON/OFF.
- Moving Object (if so equipped)
Allows user to turn the Moving Object Detection (MOD) ON/OFF.
- Front Sonar
Allows user to turn the front sonar ON/OFF.
- Rear Sonar
Allows user to turn the rear sonar ON/OFF.
- Sonar Distance
Allows user to select an item from below.
 - Long
 - Medium
 - Short

- Auto Show Sonar
Allows user to turn the sonar system display ON/OFF.
- Sonar Volume
Allows user to select an item from below.
 - High
 - Medium
 - Low

(See “Rear Cross Traffic Alert (RCTA)” (P.5-75), “Moving Object Detection (MOD)” (P.4-23) and “Sonar system” (P.5-160) .)

Driver Monitor:

- Driver Alertness
Allows user to turn the function ON/OFF.
- Driver Monitor (if so equipped)
Allows user to turn the function ON/OFF.

(See “Intelligent Driver Alertness (I-DA)” (P.5-139) and “Driver Monitor” (P.5-111).)

Sound Setting:

- Voice Guidance
Allows user to turn the function ON/OFF.
- Warning Volume
Allows user to select an item from below.

- Low
- Medium
- High

Timer Alert:

Allows user to adjust the Timer Alert or reset.

- (Current Time)/(Set Time)
- Reset

Low Temp. Alert:

Allows user to turn the Low Temperature Alert function ON/OFF.

Chassis Control:

- Trace Control
Allows user to turn the function ON/OFF.

(See “Intelligent Trace Control” (P.5-158).)

e-Step:

- Retain Mode
Allows user to turn the mode memory function ON/OFF.

In case of memory setting ON, maintain the e-Step system setting from the last time after the EV system restarts.

For more information, see “e-Step system” (P.5-21).

Personal Display

To change the display in the “Personal Display” menu, use the scroll dial ① to select and change a menu item:

- Blank
- Navigation
- Time to Destination
- Energy Economy
 - Manual Reset1
 - Manual Reset2
 - Since Charge
- Trip
 - Manual Reset1
 - Manual Reset2
 - Since Charge
- Gear Position
- Average Speed
 - Manual Reset1
 - Manual Reset2
 - Since Charge
- Brake Light

Head-Up Display

To change the status or turn on or off any of the systems displayed in the “Head-Up Display” menu, use the scroll dial ① to select and change a menu item:

- Brightness

- Height
- Rotation
- Contents Selection
 - Navigation
 - Driving Assist
 - Speed Limit Sign
 - Audio
 - TEL/SMS
- Reset

(See “Head Up Display (HUD)” (P.2-51).)

ECO Mode Setting

This setting allows user to change the ECO mode system settings.

- ECO Drive Assist
 - ECO Indicator
 - ECO Drive Report
- View History
 - Reset
Allows user to reset this item.
- Tire Press ECO advice
Allows user to turn the function ON/OFF. (See “Tire Pres ECO advice” (P.5-30).)

TPMS setting

Tire Pressure Unit:

Allows user to select a unit.

If necessary, refer to the following table to convert between units.

kPa	psi	bar	kgf/cm ²
200	29	2.0	2.0
210	30	2.1	2.1
220	32	2.2	2.2
230	33	2.3	2.3
240	35	2.4	2.4
250	36	2.5	2.5
250	36	2.5	2.5
260	38	2.6	2.6
270	39	2.7	2.7
280	41	2.8	2.8
290	42	2.9	2.9
300	44	3.0	3.0
310	45	3.1	3.1
320	46	3.2	3.2
330	48	3.3	3.3
340	49	3.4	3.4

Clock

Allows user to adjust the clock settings and time within the vehicle information display.

- Display
- Clock Mode
- Clock Format
- Daylight Saving
- Time Zone
- Set Clock Manually

The clock may also be set in the center display. For additional information, refer to the separate NissanConnect® Owner’s Manual.

Vehicle Settings

The vehicle settings allows user to change settings for the following menus.

- Power Back Door
- Lighting
- Turn indicator
- Locking
- Wipers
- Driving Position
- Rear Door Alert
- Mirrors

The vehicle settings can be changed using the scroll dial ①.

Power Back Door:

This allows user to turn the power liftgate ON or OFF.

Lighting:

The "Lighting" menu has the following options:

- Welcome Headlight
Allows user to turn this feature ON or OFF.
- Accent Lighting
Allows user to adjust the illuminance.
- Ambient Lighting (if so equipped)
Allows user to adjust the illuminance. (See "ProPILOT Assist 2.0 mode indicators" (P.5-86).)
- Auto Headlight (if so equipped)
Allows user to select an item below.
 - Turn on earliest
 - Turn on earlier
 - Turn on standard
 - Turn on later
- Light Off Delay
The duration of the automatic headlights can be changed from 0 to 180 seconds. Use the scroll dial to change the duration.

Turn indicator:

The "Lighting" menu has the following options:

- 3 Flash
- Continuous

Locking:

The "Locking" menu has the following options:

- Ext, Door Switch
When this item is turned on, the lock or capacitive unlock sensors (on the door handles) and the request switch are activated.
- Selective Unlock
When this item is turned on, only the corresponding door is unlocked when using the capacitive unlock sensor on the driver's door handle or the request switch. All the doors can be unlocked if the lock sensor or the request switch is used again within 1 minute. When this item is turned to off, all the doors will be unlocked when using the capacitive unlock sensor or the request switch once.
- Auto Door Unlock
The feature allows user to customize the auto door unlock options. Use the scroll dial to change the mode.
 - Shift to P
 - Power OFF
 - OFF

- Horn beeps on lock
This allows user to turn the function ON or OFF
- Walk Away Lock
This allows user to turn the walk away lock function ON or OFF. (See "Walk away lock function" (P.3-11).)
- Approach Unlock
This allows user to turn the approach unlock function ON or OFF. (See "Approach unlock function" (P.3-11).)

Wipers:

The "Wipers" menu has the following options:

- Speed Dependent
The feature can be activated or deactivated.
- Rain Sensor (if so equipped)
Allows user to turn this feature ON or OFF.
- Reverse Link
The feature can be set to be ON or OFF.

Driving Position:

- Exit Seat Slide
This allows user to turn this feature ON or OFF. (See "Memory seat" (P.3-41).)

- Exit Steering Up
This allows user to turn this feature ON or OFF. (See “Memory seat” (P.3-41).)

Rear Door Alert:

The feature allows user to customize the Rear Door Alert options. Use the scroll dial ① to change the mode.

- Horn & Alert
- Alert Only
- OFF

Mirrors:

Allows user to select an item below.

- Auto Fold Off
- Unfold at Power on
- Unfold at Unlock

EV Settings

- Chg. Connector Lock
Allows user to select an item below.
 - AUTO
 - LOCK
 - UNLOCK
- Charge Time Screen
Allows user to select an item below.
 - 130 kW (Quick Charge)
 - 50 kW (Quick Charge)

- 7.2 kW (Level 2)
- 1.4 kW (Level 1)

- Battery Cooling Assist
Allows user to turn this feature ON or OFF.

When this item is turned on, cooling capacity of the lithium ion (Li-ion) battery is enhanced while quick charging. (For example, when driving and using the quick charger frequently in summer.) When activated, the operation sound of air conditioner, etc. may be heard louder while quick charging.

Maintenance

The following items are available in this menu.

- Tire
- Other

Tire:

This indicator appears when the user set distance comes for replacing tires. You can set or reset the distance for replacing tires.



WARNING

The tire replacement indicator is not a substitute for regular tire checks, including tire pressure checks. (See

“Changing wheels and tires” (P.8-27).) Many factors including tire inflation, alignment, driving habits and road conditions affect tire wear and when tires should be replaced. Setting the tire replacement indicator for a certain driving distance does not mean your tires will last that long. Use the tire replacement indicator as a guide only and always perform regular tire checks. Failure to perform regular tire checks, including tire pressure checks could result in tire failure. Serious vehicle damage could occur and may lead to a collision, which could result in serious personal injury or death.

Other:

This indicator appears when the user set distance comes for checking or replacing maintenance items other than tires. Other maintenance items can include such things as air filter or tire rotation. You can set or reset the distance for checking or replacing the items.

Customize Display

The Customize Display allows user to choose from the various meter selections.

The Customize Display can be changed using the scroll dial ①.

Main Menu Selection:

Displays available screens that can be shown in the vehicle information display.

Route Guidance:

- Alerts

Allows user to turn the Navigation Settings alerts ON or OFF.

Transition (Cruise) (if so equipped):

Allows user to turn the cruise screen transition ON or OFF.

Welcome Effect:

The "Welcome Effect" displays the available welcome effect settings.

- Animation
- Sound

Operation Guidance:

The "Operation Guidance" displays the available operation guidance settings.

- Lights
- Wiper
 - Front

— Rear

- High Beam Assist
- Seat Memory

Unit/Language

The units or language that are shown in the vehicle information display can be changed:

- Mileage/Energy
- Tire Pressure
- Temperature
- Language

Use the scroll dial ① to select and change the units of the vehicle information display.

Mileage/Energy:

The unit for the mileage that is shown in the vehicle information display can be changed.

Tire Pressure:

The unit for tire pressures that is shown in the vehicle information display can be changed.

(See "TPMS setting" (P.2-28).)

Temperature:

The temperature that is shown in the vehicle information display can be changed.





















Language:

The language of the vehicle information display can be changed.

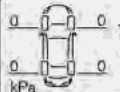





















Factory Reset

The settings in the vehicle information display can be reset back to the factory default. To reset the vehicle information display:

1. Select "Factory Reset" using the scroll dial ① and push it.
2. Select "Yes" to return all settings back to default by pushing the scroll dial ①.

 <p>BRAKE</p> <p>Push brake and power switch to drive</p>	1	 <p>Release Parking Brake</p>	8	 <p>When parked apply parking brake</p>	15	<p>Power turned off to save the battery</p>	23	 <p>Battery charge is low Power reduced Charge now</p>	31
 <p>No Key Detected</p>	2		9	<p>T/M system malfunction Visit dealer</p>	16	 <p>Reminder Turn OFF Headlights</p>	24	 <p>Power reduced</p>	32
 <p>No Key</p> <p>Hold</p>	3		10	<p>P</p>	17	<p>Headlight System Error See Owner's Manual</p>	25	 <p>Can't start Charging plug connected</p>	33
 <p>Key Battery Low</p>	4	 <p>Low Washer Fluid</p>	11	<p>ECO</p>	18	 <p>Time for a break?</p>	26	<p>Battery thermal runaway Stop safely Evacuate to safe area outside car</p>	34
 <p>Place the key near the power switch</p>	5	 <p>Tire Pressure Low Add Air kPa</p>	12	<p>e-Step</p>	19	<p>Chassis Control System Error See Owner's Manual</p>	27	<p>Battery thermal runaway Evacuate to safe area outside car</p>	35
 <p>Key System Error See Owner's Manual</p>	6	<p>Tire Pressure Low Check Cold Tire</p>	13	<p>e-Step system failure Press brake pedal to slow or stop</p>	20	 <p>Battery too Low Please charge now</p>	28	<p>Service EV System Power Reduced Stop Safely</p>	36
 <p>Shift to Park</p>	7	<p>Check position of shift lever</p>	14	<p>Shipping Mode On Push Storage Fuse</p>	21	 <p>EV system hot Power reduced Drive slowly</p>	29	<p>12V POWER SYSTEM ERROR Visit dealer</p>	37
				<p>Power will turn off to save the battery</p>	22	 <p>EV system cold Power reduced</p>	30		

WBC0140X

Enhanced cooling when quick charging may result in increased noise	38	 Warning	47	Unavailable Camera Temperature High	54	Unavailable Parking Brake is ON	63	Press brake pedal to prevent rolling	71
	39	 Warning	48	Currently Unavailable	55	 Warning Step on Brake Now	64	AUTO HOLD  Press brake to operate switch	72
	40	 Warning Take Steering Control	49	Forward Driving Aids temporarily disabled Front Sensor blocked See Owner's Manual	56	Follow Vehicle Ahead	65	AUTO HOLD  Caution Steep slope	73
	41	 Warning	50	Unavailable Side Radar Obstruction	57	Only Available with Cruise Control ON	66	AUTO HOLD  Steep Slope Apply foot brake	74
	42	 Warning Manually Steer	51	Unavailable Slippery Road	58	Driver Monitor Camera Malfunction	67	Rear Door Alert is Activated	75
	43	 Warning Slowing to Stop	52	Unavailable Seatbelt is Unfastened	59		68	Dismiss Message Disable Alert	75
	44	 Warning	53	Unavailable Adverse Weather	60	Parking Sensor Error See Owner's Manual	69	Check Rear Seat for All Articles	76
	45	 Warning Look Forward		Unavailable Low Visibility	61		70		
	46	Malfunction See Owner's Manual		Steering Assist Not Available Cannot Detect Lanes	62				

WBC0141X

VEHICLE INFORMATION DISPLAY WARNINGS AND INDICATORS

The displayed images and the displayed items may differ depending on the model.

1. Push brake and power switch to drive

This indicator appears while the vehicle is in the P (Park) position.

This indicator means that the EV system will start when the power switch is pushed with the brake pedal depressed.

2. No key detected warning

This warning appears in either of the following conditions:

No key inside the vehicle:

This warning appears when the door is closed with the Intelligent Key left outside the vehicle and the power switch in the READY to drive position. Make sure that the Intelligent Key is inside the vehicle.

Unregistered Intelligent Key:

This warning appears when the power switch is changed to the READY to drive position from the OFF position and the Intelligent Key cannot be recognized by the system. You cannot place the power switch in the READY to drive position with an unregistered key. Use an Intelligent

Key that has been registered.

3. No Key Hold power switch indicator

This indicator appears when you try to turn off the EV system with the door closed and the Intelligent Key left outside the vehicle and the EV system is running. Push and hold the power switch to turn off the EV system.

(See "Intelligent Key system" (P.3-6).)

4. Key Battery Low warning

This warning appears when the Intelligent Key battery is running out of power. If this indicator appears, replace the battery with a new one. See "Intelligent Key battery replacement" (P.8-13).

5. Hold Key Near Start Button indicator

This indicator appears when the Intelligent Key battery is running out of power and when the Intelligent Key system and vehicle are not communicating normally.

If this indicator appears, touch the power switch with the Intelligent Key while depressing the brake pedal. (See "Intelligent Key battery discharge" (P.5-16).)

6. Key System Error: See Owner's Manual warning

This warning appears if there is a malfunction in the Intelligent Key system.

If this warning appears while the traction motor is stopped, the power switch cannot be switched to the READY to drive position. If this warning appears while the power switch is in the READY to drive position, the vehicle can be driven. However, it is recommended that you contact a NISSAN certified ARIYA dealer.

7. Shift to P range warning

This warning appears when the driver's door is opened while the shift lever is in any position other than P (Park).

If this warning appears, push the park button to engage the P (Park) position.

An inside warning chime will also sound. (See "Intelligent Key system" (P.3-6).)

8. Release Parking Brake warning

This warning appears when the accelerator pedal is depressed when the electronic parking brake automatic release function cannot be used. Release the electronic parking brake manually.

9. Door/liftgate open warning

This warning appears if any of the doors and/or the liftgate are open or not closed securely. The vehicle icon indicates which door or the liftgate is open on the display.

10. Rear seat belt warning

This rear seat belt warning appears after the power switch is placed to the ON position. If any of the rear passenger's seat belts is not fastened, the seat icon illuminates in red to show which seat belt is not fastened. The seat icon illuminates in red until the corresponding rear passenger's seat belt is fastened. The warning will automatically turn off after approximately 65 seconds. If so equipped, the seat icon will turn gray (or green, depending on the models) if the seat is occupied and the passenger is buckled. If a rear passenger seat belt is fastened then unfastened at a vehicle speed less than approximately 10 MPH (15 km/h), the seat icon will illuminate. When the vehicle speed exceeds approximately 10 MPH (15 km/h), the seat icon will blink and the chime will sound. The warning will turn off when a rear passenger seat belt is fastened or automatically turn off approximately 65 seconds after the seat belt is unfastened. For precautions on seat belt usage, see "Seat belts" (P.1-14).

The display of the rear seat belt warning varies depending on the number of seats.

11. Low Washer Fluid warning (if so equipped)

This warning appears when the window washer fluid is at a low level. Add window washer fluid as necessary. For additional information, refer to "Window washer fluid" (P.8-10).

12. Tire Pressure Low - Add Air warning

This warning appears when the low tire pressure warning light in the meter illuminates and low tire pressure is detected. The warning appears each time the power switch is placed in the ON position as long as the low tire pressure warning light remains illuminated. If this warning appears, stop the vehicle and adjust the pressure to the recommended COLD tire pressure shown on the Tire and Loading Information label. (See "Low tire pressure warning light" (P.2-17) and "Tire Pressure Monitoring System (TPMS)" (P.5-5).)

13. Tire Pressure Low Check Cold Tire warning

This warning appears if the tire pressure becomes higher than the target pressure during a low tire pressure condition.

Even if the tire pressure is above the preset target pressure, the yellow color in the tire pressure warning means that the tire pressure is actually too low. Tire pressure is increasing during driving. Check the tire pressure when the tire is cold.

14. Check position of shift lever warning

This warning appears if the system cannot detect the shift position. Make sure the vehicle is placed in a position properly. Have the system checked. It is recommended you contact a NISSAN certified ARIYA dealer for this service.

15. When parked apply parking brake warning

This warning appears if a malfunction occurs in the electric shift control system. It is recommended that you contact a NISSAN certified ARIYA dealer as soon as possible. When parking the vehicle, make sure that the parking brake is applied. If the parking brake is not applied, the power switch may not be turned off.

If the power switch cannot be placed in the OFF position, apply the parking brake and then place it in the OFF position.

The message on the vehicle information display turns off and the chime stops. Have the system checked. It is recommended that you visit a NISSAN certified ARIYA dealer.

16. T/M system malfunction warning

This warning appears if there is a malfunction in the electric shift control system.

- When shifting, hold the shift lever in the shift position and check the shift position indicator on the shift lever or on the vehicle information display to make sure that shifting has been performed properly.
- When parking, push the park button to engage the P (Park) position. (The vehicle may not automatically apply the P (Park) position.)

Have the system checked as soon as possible. It is recommended that you contact a NISSAN certified ARIYA dealer for this service.

17. Shift position indicator

This indicator shows the shift position.

See "Electric shift control system" (P.5-17) for further details.

18. Drive Mode Selector indicator

When a driving mode is selected using the Drive Mode Selector, the selected mode indicator is displayed.

- SPORT
- STANDARD
- ECO
- SNOW (AWD models)

(See "Drive Mode Selector" (P.5-29).)

19. e-Step indicator

This indicator shows the status of the e-Step system. (See "e-Step indicator" (P.2-10) and "e-Step system" (P.5-21).)

20. e-Step system failure Press brake pedal to slow or stop warning

This warning appears when the e-Step system is malfunctioning. Have the system checked soon. It is recommended that you visit a NISSAN certified ARIYA dealer.

21. Shipping Mode On Push Storage Fuse warning

This warning may appear if the extended storage switch is not pushed in. When this warning appears, it is recommended that you contact a NISSAN certified ARIYA dealer.

22. Power will turn off to save the battery warning

Under the specific conditions, this warning may appear after the power switch is in the ON position for a certain period of time.

23. Power turned off to save the battery warning

Under the specific conditions, this warning may appear after the power switch is automatically turned OFF to save the battery.

24. Reminder Turn OFF Headlights warning

This warning appears when the driver side door is opened with the headlight switch is left ON and the power switch is placed in the OFF position. Place the headlight switch in the OFF (if so equipped) or AUTO position. For additional information, see "Headlight and turn signal switch" (P.2-61).

25. Headlight system Error: See Owner's Manual warning

This warning appears if the LED headlights are malfunctioning. Have the system checked. It is recommended that you visit a NISSAN certified ARIYA dealer for this service.

26. Time for a break? indicator

This indicator appears when the set Timer Alert activates. You can set the time for up to 6 hours.

27. Chassis control system Error: See Owner's Manual warning

This warning appears if the chassis control module detects a malfunction in the chassis control system. Have the system checked. It is recommended that you visit a NISSAN certified ARIYA dealer for this service. (See "Chassis control" (P.5-158).)

28. Battery too Low Please charge now warning

This warning appears when the Li-ion battery charge is getting low. The low battery charge warning light and the master warning light also illuminate. Charge the Li-ion battery as soon as possible.

29. Power limitation (hot) warning

This warning appears when the temperature of the traction motor, Li-ion battery, etc. becomes extremely high due to driving in high outside air temperatures, continuous driving at high speed or on uphill climbs, etc. when the power limitation indicator illuminates. If this warning appears, vehicle speed will not increase due to the power limitation even if the accelerator pedal is depressed.

30. Power limitation (cold) warning

This warning appears when the temperature of Li-ion battery becomes extremely low under extremely low outside air temperatures, etc. when the power limitation indicator illuminates. If this warning appears, vehicle speed will not increase due to the power limitation even if the accelerator pedal is depressed.

31. Power limitation (low charge) warning

This warning appears when the remaining capacity of Li-ion battery becomes extremely low when the power limitation indicator illuminates. If this warning appears, vehicle speed will not increase due to the power limitation even if the accelerator pedal is depressed.

If the warning appears due to the ex-

remely low remaining capacity of Li-ion battery, stop the vehicle in a safe location and it is recommended that you contact a NISSAN certified ARIYA dealer.

32. Power limitation (other) warning

This warning appears due to reasons other than above power limitation warnings (hot, cold or low charge). If this warning appears, vehicle speed will not increase due to the power limitation even if the accelerator pedal is depressed.

33. Can't start Charging plug Connected warning

This warning appears when the power switch is in the ON position and if the power switch is pushed to the READY to drive position with the brake pedal depressed, while the charge connector is inserted to the vehicle. Remove the charge connector.

34. Battery thermal runaway Stop safely Evacuate to safe area outside car warning

This warning appears if the Li-ion battery is malfunctioning and a danger of the Li-ion battery thermal runaway is detected while driving.

Pull off the road to a safe location immediately, leave the vehicle and it is

recommended that you contact a NISSAN certified ARIYA dealer.

35. Battery thermal runaway Evacuate to safe area outside car warning

This warning appears if the Li-ion battery is malfunctioning and a danger of the Li-ion battery thermal runaway is detected when the vehicle is stopped.

Leave the vehicle and it is recommended that you contact a NISSAN certified ARIYA dealer.

36. Service EV System Power Reduced Stop Safely warning

This warning appears if there is a malfunction in the EV system and the power provided to the traction motor is reduced.

The message will vary depending on the condition of the system malfunction. Be sure to follow the displayed instruction.

37. 12V POWER System ERROR Visit dealer warning

This warning appears when there is a malfunction with the 12-volt battery system.

If this warning continues to appear, have the system checked. It is recommended that you visit a NISSAN certified ARIYA

dealer for this service.

38. Battery Cooling Assist ON indicator

This indicator appears when "Battery Cooling Assist" is turned on using the settings menu of the vehicle information display. (See "EV Settings" (P.2-30).)

39. Lane Departure Warning (LDW)/Intelligent Lane Intervention (I-LI) indicator

This indicator appears when the Lane Departure Warning (LDW) and/or Intelligent Lane Intervention (I-LI) systems are engaged.

(See "Lane Departure Warning (LDW)" (P.5-44) or "Intelligent Lane Intervention (I-LI)" (P.5-49).)

40. Blind Spot Warning (BSW)/Intelligent Blind Spot Intervention (I-BSI) indicator

This indicator appears when the Blind Spot Warning (BSW) and/or Intelligent Blind Spot Intervention (I-BSI) systems are engaged.

(See "Blind Spot Warning (BSW)" (P.5-55) or "Intelligent Blind Spot Intervention (I-BSI)" (P.5-63).)

41. Vehicle ahead detection indicator

This indicator shows the status of the following systems:

- Automatic Emergency Braking (AEB) with Pedestrian Detection
- Intelligent Forward Collision Warning (I-FCW)

(See "Automatic Emergency Braking (AEB) with Pedestrian Detection system" (P.5-120) or "Intelligent Forward Collision Warning (I-FCW)" (P.5-130).)

42. Cruise indicator

This indicator shows the conventional (fixed speed) cruise control mode status. The status is shown by the color. (See "ProPILOT Assist Systems" (P.5-82).)

43. Speed control status/set distance/lane marker indicator

This indicator shows the status of the ProPILOT Assist system and the detection of the lane markers. The status is shown by the color and shape. (See "ProPILOT Assist Systems" (P.5-82).)

44. Intelligent Lane Intervention (I-LI) ON/Intelligent Blind Spot Intervention (I-BSI) ON/ProPILOT Assist system status indicator

This indicator appears when the following systems are turned on:

- Intelligent Lane Intervention (I-LI)
- Intelligent Blind Spot Intervention (I-BSI)
- ProPILOT Assist

(See "Intelligent Lane Intervention (I-LI)" (P.5-49),"Intelligent Blind Spot Intervention (I-BSI)" (P.5-63) or "ProPILOT Assist Systems" (P.5-82).)

45. Look Forward warning (if so equipped)

This warning may appear if the system does not detect driver's attention on the road ahead.

Always look forward, drive carefully and pay attention to traffic conditions ahead. When the driver looks forward, the warning turns off.

For additional information, refer to "Driver Monitor" (P.5-111).

46. Steering Assist indicator

This indicator appears when the Steering Assist system is engaged.

See "ProPILOT Assist Systems" (P.5-82).

47-50. Hands on/Eyes off detection warning (if so equipped)

This warning may appear when the Steering Assist system is engaged and the following condition(s) occur:

- When not holding the steering wheel
- When there is no steering wheel operation

Hold on the steering wheel immediately. When the steering operation is detected, the warning turns off and the Steering Assist function is automatically restored. For additional information, refer to "ProPILOT Assist Systems" (P.5-82).

51. Rear Automatic Braking (RAB) system warning indicator

This warning indicator appears to indicate the status of the Rear Automatic Braking (RAB) system.

See "Rear Automatic Braking (RAB)" (P.5-141).

52. Automatic Emergency Braking (AEB) emergency warning indicator

This warning indicator appears along with an audible warning, when the Automatic Emergency Braking (AEB) with Pedestrian Detection system detects the possibility of a forward collision.

See "Automatic Emergency Braking (AEB) with Pedestrian Detection system" (P.5-120).

53. Malfunction See Owner's Manual warning

This warning appears when the following systems (if so equipped) malfunction.

- Traffic Sign Recognition (TSR)
- Lane Departure Warning (LDW)
- Intelligent Lane Intervention (I-LI)
- Blind Spot Warning (BSW)
- Intelligent Blind Spot Intervention (I-BSI)
- ProPILOT Assist
- Steering Assist
- Rear Automatic Braking (RAB)
- Intelligent Driver Alertness (I-DA)
- Rear Cross Traffic Alert (RCTA)
- Automatic Emergency Braking (AEB) with Pedestrian Detection

- Intelligent Forward Collision Warning (I-FCW)

(See "Traffic Sign Recognition (TSR)" (P.5-40), "Lane Departure Warning (LDW)" (P.5-44), "Intelligent Lane Intervention (I-LI)" (P.5-49), "Blind Spot Warning (BSW)" (P.5-55), "Intelligent Blind Spot Intervention (I-BSI)" (P.5-63), "Rear Cross Traffic Alert (RCTA)" (P.5-75), "ProPILOT Assist Systems" (P.5-82), "Rear Automatic Braking (RAB)" (P.5-141), "Intelligent Driver Alertness (I-DA)" (P.5-139), "Rear Cross Traffic Alert (RCTA)" (P.5-75), "Automatic Emergency Braking (AEB) with Pedestrian Detection system" (P.5-120) or "Intelligent Forward Collision Warning (I-FCW)" (P.5-130).)

54. Unavailable Camera Temperature High warning

This warning appears if the interior temperature of the vehicle has reached such a high temperature that the sensor for the following systems (if so equipped) can no longer function reliably.

- Lane Departure Warning (LDW)
- Intelligent Lane Intervention (I-LI)
- Intelligent Blind Spot Intervention (I-BSI)
- Steering Assist

Once the interior temperature has reached normal levels, the warning should disappear.

2-40 Instruments and controls

If the warning continues to display, have the system checked. It is recommended that you visit a NISSAN certified ARIYA dealer for this service.

For additional information, refer to "Lane Departure Warning (LDW)" (P.5-44), "Intelligent Lane Intervention (I-LI)" (P.5-49), "Intelligent Blind Spot Intervention (I-BSI)" (P.5-63) or "Steering Assist" (P.5-106).

55. Currently Unavailable warning

This warning appears when the following systems (if so equipped) become unavailable because the Vehicle Dynamic Control (VDC) system is turned off or the SNOW mode is selected (AWD models).

- Intelligent Lane Intervention (I-LI)
- Intelligent Blind Spot Intervention (I-BSI)
- ProPILOT Assist

For additional information, refer to "Vehicle Dynamic Control (VDC) system" (P.5-155), "Intelligent Lane Intervention (I-LI)" (P.5-49), "Intelligent Blind Spot Intervention (I-BSI)" (P.5-63), "ProPILOT Assist Systems" (P.5-82).

56. Forward Driving Aids temporarily disabled Front Sensor blocked See Owner's Manual warning

If the front radar sensor area on the front of the vehicle is covered with dirt or obstructed, making it impossible to detect a vehicle ahead, the following system is automatically turned off.

- ProPILOT Assist
- Automatic Emergency Braking (AEB) with Pedestrian Detection
- Intelligent Forward Collision Warning (I-FCW)

If the warning message appears, park the vehicle in a safe location and turn the EV system off.

Check to see if the sensor area is blocked. If the sensor area is blocked, remove the blocking material. Restart the EV system. If the warning message continues to appear, have the system checked. It is recommended that you visit a NISSAN certified ARIYA dealer for this service.

For more details, see "ProPILOT Assist Systems" (P.5-82), "Automatic Emergency Braking (AEB) with Pedestrian Detection system" (P.5-120) or "Intelligent Forward Collision Warning (I-FCW)" (P.5-130).

57. Unavailable Side Radar Obstruction warning

This warning appears when the following systems (if so equipped) become unavailable because a radar blockage is detected.

- Blind Spot Warning (BSW)
- Intelligent Blind Spot Intervention (I-BSI)
- Rear Cross Traffic Alert (RCTA)

(See "Blind Spot Warning (BSW)" (P.5-55), "Intelligent Blind Spot Intervention (I-BSI)" (P.5-63) or "Rear Cross Traffic Alert (RCTA)" (P.5-75).)

58. Unavailable Slippery Road warning

This warning appears when the following systems (if so equipped) become unavailable because the road is slippery.

- Intelligent Lane Intervention (I-LI)
- Intelligent Blind Spot Intervention (I-BSI)
- ProPILOT Assist

(See "Intelligent Lane Intervention (I-LI)" (P.5-49), "Intelligent Blind Spot Intervention (I-BSI)" (P.5-63) or "ProPILOT Assist Systems" (P.5-82).)

59. Unavailable Seatbelt is Unfastened indicator

This message may appear when the ProPILOT Assist system is engaged.

Under the following condition, the ProPILOT Assist system is automatically canceled:

- When the driver's seat belt is not fastened.

The ProPILOT Assist system cannot be used when the driver's seat belt is not fastened.

60. Unavailable Adverse Weather indicator

This message may appear when the Steering Assist system is engaged.

Under the following conditions, the Steering Assist system is automatically canceled:

- When the wiper (HI) operates.
- When lane markers in the traveling lane cannot be correctly detected for a period of time due to such items as a snow rut, reflection of light on a rainy day or several unclear lane markers are present.

If you want to use the Steering Assist system again, cancel the ProPILOT Assist system and set it again when lane

markers are clearly visible.

61. Unavailable Low Visibility indicator

This message may appear when the Steering Assist system is engaged.

Under the following conditions, the Steering Assist system is automatically canceled:

- The camera area of the windshield is fogged up or covered with dirt, water, drops, ice, snow, etc.
- Strong light, such as sunlight or high beams from oncoming vehicles, enter the front camera

62. Steering Assist Not Available Cannot Detect Lane indicator

This indicator may appear when the Steering Assist system is engaged. The Steering Assist system is automatically canceled when the lane markers in the traveling lane cannot be correctly detected for a period of time due to such items as a snow rut, reflection of light on a rainy day or several unclear lane markers are present.

If you want to use the Steering Assist system again, cancel the ProPILOT Assist system and set it again when lane markers are clearly visible.

63. Unavailable Parking Brake is ON indicator

This message may appear when the ProPILOT Assist system is engaged.

Under the following condition, the ProPILOT Assist system is automatically canceled:

- The electronic parking brake is applied.

The above system cannot be used when the electronic parking brake is activated.

64. Step on Brake Now indicator

This message may appear when the Intelligent Cruise Control (ICC) system is engaged and the following condition occurs:

- While the vehicle is stopped by the ICC system, the driver's door is opened but the electronic parking brake was not activated.

Step on the brake pedal immediately.

65. Follow Vehicle Ahead indicator

When ProPILOT Assist with Navi-link or ProPILOT Assist 2.0 is activated, if the vehicle ahead stops and your vehicle is stopped less than approximately 30 seconds on the freeway, this message will appear. When the vehicle ahead begins to move, your vehicle will start moving

automatically. (See "ProPILOT Assist Systems" (P.5-82).)

66. Only Available with Cruise Control ON indicator

This indicator appears when the Steering Assist switch is pushed while the ProPILOT Assist system is not turned on. (See "ProPILOT Assist Systems" (P.5-82).)

67. Driver Monitor Camera Malfunction (if so equipped)

This warning appears when there is a malfunction with the Driver Monitor system. (See "Driver Monitor" (P.5-111).)

68. Sonar indicator

This indicator appears to indicate the status of the sonar system.

See "Sonar system" (P.5-160).

69. Parking Sensor Error warning

This warning appears when there is a malfunction with the sonar system. (See "Sonar system" (P.5-160).)

70. Take a break? indicator

This indicator appears when the Intelligent Driver Alertness (I-DA) system detects that the driver attention is decreasing. (See "Intelligent Driver Alertness (I-DA)" (P.5-139).)

71. Press brake pedal to prevent rolling warning

This warning appears in the following situations:

- The driver tries to release the electronic parking brake manually without depressing the brake pedal.
- The vehicle is stopped on a steep hill and there is a possibility of moving backward, even if the electronic parking brake is applied.
- This warning appears and a chime sounds if the vehicle moves while the automatic brake hold function is activated. Apply the foot brake to stop the vehicle moving.

72. Press brake to operate switch indicator

This indicator appears if the automatic brake hold switch is pushed without depressing the brake pedal while the automatic brake hold function is activated. Depress the brake pedal and push the switch to deactivate the automatic

brake hold function. (See “Automatic brake hold” (P.5-26).)

73. Caution Steep slope indicator

This indicator appears and a chime sounds when the automatic brake hold function is activated while the vehicle is on a steep hill. Apply the foot brake to stop the vehicle moving. (See “Automatic brake hold” (P.5-26).)

74. Steep Slope Apply foot brake indicator

This indicator appears and a chime sounds if “Caution Steep slope” has appeared over about 3 minutes. Then, the parking brake will automatically be applied and the brake force of the automatic brake hold will be released, and vehicle may move or roll away unexpectedly. Apply the foot brake to stop the vehicle moving. (See “Automatic brake hold” (P.5-26).)

75. Rear Door Alert is activated indicator

When the system is enabled, this message appears when the Rear Door Alert system is active and can remind the driver to check the rear seat.

- Using the steering switch, the driver can select “Dismiss Message” to clear

the display for a period of time.

- Using the steering switch, the driver can select “Disable Alert” to disable the horn alert for the remainder of the current trip.

For additional information, see “Rear Door Alert” (P.2-75).



WARNING

Selecting “Dismiss Message” during a stop within a trip temporarily dismisses the message for that stop without turning the system off. Alerts can be provided for other stops during the trip. Selecting “Disable Alert” turns off the Rear Door Alert system for the remainder of a trip and no audible alert will be provided.

NOTE:

This system is disabled until the driver enables it using the settings menu. See “Vehicle Settings” (P.2-28).

76. Check Rear Seat For all articles indicator

When the system is enabled, this message appears when the vehicle comes to a complete stop, the shift position is placed from the D (Drive) to P (Park), and the driver exits the vehicle. This message alerts the driver, after a period of time, to check for items in the rear seat after the audible alert has been provided.

NOTE:

This system is disabled until the driver enables it using the settings menu. See “Vehicle Settings” (P.2-28).



1

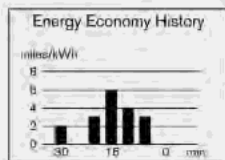

5

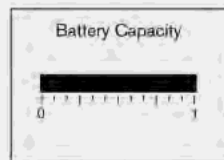

9



13

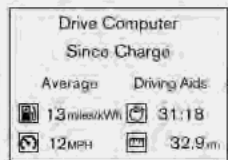

2

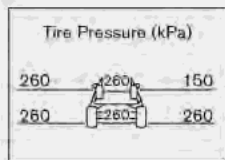

6

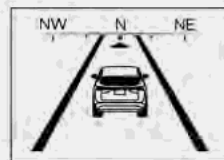

10

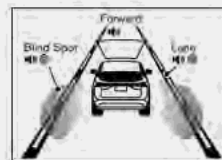

14

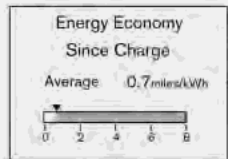

3

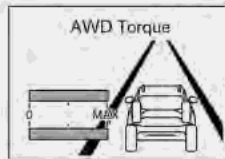

7



11



15

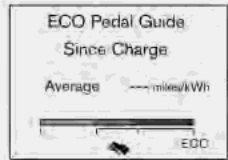

4

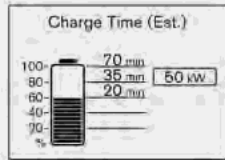

8



12

WBC0137X

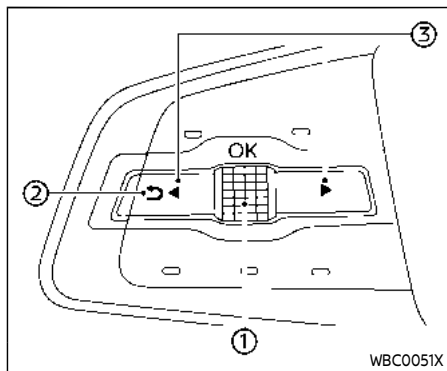

TRIP COMPUTER

Switches for the trip computer are located on the left side of the steering wheel.

- ① Scroll dial - navigate through the items and change or select an item in vehicle information display
this scroll dial allows up/down navigation and push to select
- ② ◀ - go back to the previous menu
- ③ ▶ - change from one display screen to the next (i.e. trip, energy economy)

The displayed images and displayed items may differ depending on the model.

1. Home

The Home mode shows the following information.

- Vehicle speed
- Navigation
- Audio

2. Drive Computer

Average energy consumption:

This shows the average energy consumption since the last reset.

Average speed:

This shows the average vehicle speed since the last reset.

Trip odometer:

This shows the total distance the vehicle has been driven since the last reset.

Elapsed time:

This shows the elapsed time since the last reset.

The Drive Computer mode has three modes of operation. You can switch between Manual Reset1, Manual Reset2 or Since Charge by pushing the scroll dial ①.

Manual Reset1 and Manual Reset2 can be reset manually by using the scroll dial ①. Since Charge will be reset automatically

each time when charging.

3. Energy Economy

Current energy consumption:

This shows the current energy consumption.

Average energy consumption:

This shows the average energy consumption since the last reset.

The Energy Economy mode has three modes of operation. You can switch between Manual Reset1, Manual Reset2 or Since Charge by pushing the scroll dial ①.

Manual Reset1 and Manual Reset2 can be reset manually by using the scroll dial ①. Since Charge will be reset automatically each time when charging.

4. ECO Pedal Guide

When the ECO mode is selected, you can view the ECO Pedal Guide function for improving energy economy.

The ECO Pedal Guide mode have three modes of operation. You can switch between Manual Reset1, Manual Reset2 or Since Charge by pushing the scroll dial ①.

Manual Reset1 and Manual Reset2 can be reset manually by using the scroll dial ①.

Since Charge will be reset automatically each time when charging.

(See "ECO Pedal Guide function" (P.5-31).)

5. Energy Economy History

The Energy Economy History mode shows the energy economy from the past hour by bar graph. The graph is updated every 5 minutes. The graph continues to be updated after the power switch is placed in the OFF position and will be reset after 30 minutes (on classic display) or 60 minutes (on enhanced display).

For classic display, see "Meters and gauges" (P.2-5).

For enhanced display, see "Changing the meter screen view" (P.2-6).

6. Tire Pressure

The Tire Pressure mode shows the pressure of all four tires while the vehicle is driven.

With the "Tire Pres ECO advice" function ON, when the tire pressure is getting low, "Check Tire Pressures for Best Energy Economy" appears. (See "ECO Mode Setting" (P.2-28) and "Tire Pres ECO advice" (P.5-30).)

When the "Tire Pressure Low – Add Air" warning appears, the display can be switched to the tire pressure mode by

pushing the scroll dial ① to reveal additional details on the displayed warning.

7. AWD Torque (if so equipped)

The AWD Torque mode shows the distribution ratio of the drive force to the front and rear wheels during driving.

The white bar on the display indicates power operation.

The blue bar on the display indicates regenerative operation.

8. Charge time (Est.)

The Charge Time (Est.) mode shows the estimated time to charge the Li-ion battery to a full level.

Correct estimated charge time will be displayed after 1 minute from placing the power switch in the ON position.

How to read the display:

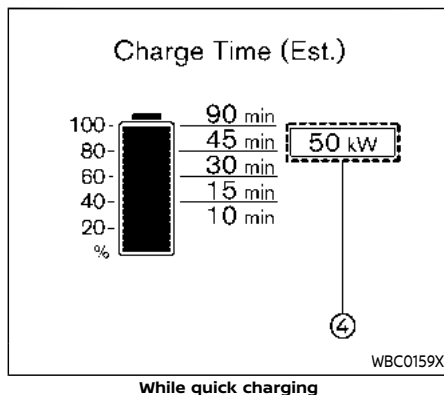
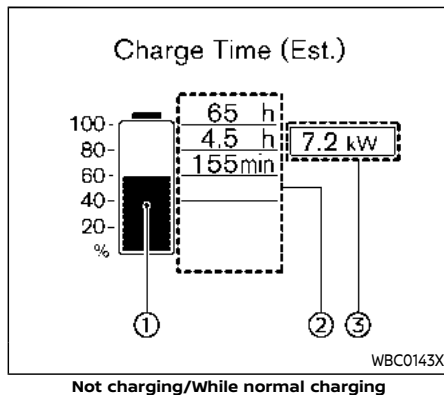

Before charging starts, the displayed charging time is calculated based on the electrical power (supplied to the charger), which is selected in the "Charge Time Screen" setting under the EV Settings menu.

While charging, the charging time is calculated based on the actual electrical power.

The display shows:

- ① The currently remaining Li-ion battery charge level.
- ② The estimated charging time to reach each percentage (20%, 40%, 60%, 80%, and 100%) of the Li-ion battery level.

NOTE:

- **If the estimated charging time is longer than 24 hours, "Over 24hr" is displayed.**
 - **When the currently remaining Li-ion battery level exceeds each percentage level, the charging time will be displayed as a blank.**
 - **When the Li-ion battery was almost fully charged, all the charging time information will be displayed as a blank.**
- ③ The actual electricity that can be supplied from the charging facility.
 - ④ The electrical power that is actually supplied while quick charging.

When charging is not performed, pushing the scroll dial on the steering wheel will switch the display to the "Charge Time Screen" menu. Select the electrical power that you wish to show in the Estimated Charge Time display.

While charging, the scroll dial cannot be operated to switch to the "Charge Time Screen" menu.

NOTE:

- **While charging, the estimated charging time is calculated based on the electrical power that is currently supplied to the charger.**
- **For the quick charging, the electrical power display will change to the actual electrical power while charging. If the charging is stopped or the power supply is stopped (unplugged, etc.), the displayed electrical power returns to the selected electrical power.**
- **The displayed charging time on each percentage level is the current estimation, and the actual charging time will vary depending on the conditions of the vehicle or the state of charge.**
- **Right after starting or stopping charge, the estimated charging time may be differ from the actual charging time. The actual charging time**

will be displayed after a while.

- **Even if the displayed charging status is "100%", charging may continue.**

9. Battery Capacity

The Battery Capacity mode shows the amount of charge the Li-ion battery is capable of storing.

When the capacity of the Li-ion battery decreases with age and usage, the level of the gauge will also decrease.

10. Compass

The Compass mode shows the heading direction of the vehicle.

11. Navigation

The Navigation mode shows the navigation route information when the route guidance is set in the navigation system.

12. Speed Limit Sign

The Traffic Sign Recognition (TSR) system provides the driver with information about the most recently detected speed limit. See "Traffic Sign Recognition (TSR)" (P.5-40) for more details.

13. Audio

The audio mode shows the status of audio information.

14. Driver Assistance

The Driver Assistance mode shows the operating condition for the following systems.

- Forward:
 - Automatic Emergency Braking (AEB) with Pedestrian Detection system
 - Intelligent Forward Collision Warning (I-FCW)
- Lane:
 - Lane Departure Warning (LDW)
 - Intelligent Lane Intervention (I-LI)
- Blind spot:
 - Blind Spot Warning (BSW)
 - Intelligent Blind Spot Intervention (I-BSI)

For more details, see "Driver Assistance display" (P.5-35).

15. ProPILOT Assist

The ProPILOT Assist mode shows the operating conditions for the following systems:

- Intelligent Cruise Control (ICC)

- Steering Assist

The display will also be shown when the ProPILOT Assist system is turned on. For additional information, see "ProPILOT Assist Systems" (P.5-82).

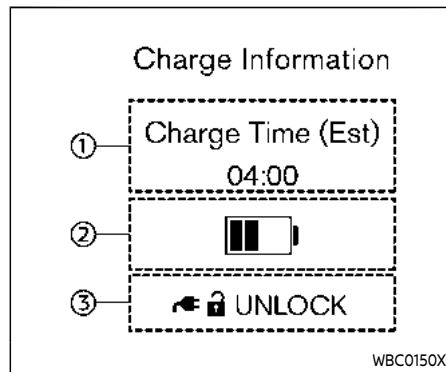

CHARGING STATUS DISPLAY

The charging status display appears for approximately 30 seconds when;

- The power switch is placed in the OFF position.
- A door is opened when the power switch is in the OFF position.
- ① Estimated charge time
- When normal or trickle charging, it shows the estimated time to charge the Li-ion battery to a full level. The time is calculated based on the electrical power (supplied to the charger).
- When quick charging, it shows the estimated remaining charging time. The displayed time may differ from

one displayed on the charger.

- To check the estimated charging time by different electrical power, refer to the time displayed in the “Charge Time (Est.)” mode. (See “8. Charge time (Est.)” (P.2-46).)
 - The displayed time may differ from one displayed on the “Charge Time (Est.)” mode, because the update timing of each display is different.
 - When the Li-ion battery temperature control system operates, longer charging time may be displayed.
- ② Li-ion battery charge level
Current Li-ion battery charge level is displayed.
- ③ Charge connector lock setting status
— The current mode of the charge connector lock (AUTO, LOCK or UNLOCK) is displayed. (See “Charge connector lock” (P.CH-33).)

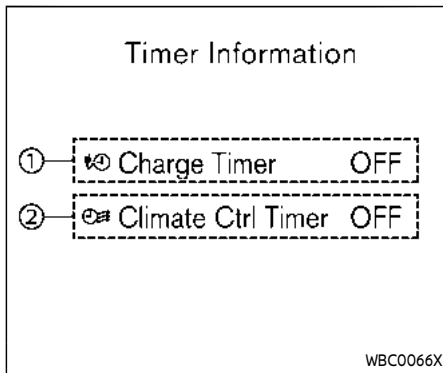

TIMER DISPLAY

The timer display appears for approximately 30 seconds when;

- The power switch is in the OFF position and a door is opened.
 - The power switch is in the OFF position and the charging connector is connected.
- ① Charging Timer status
If the charging timer is set, the Charging Timer status (ON or OFF) is displayed. (For the charging timer operation, see “Charging timer” (P.CH-35).)
- ② Climate Ctrl. Timer status
The Climate Ctrl. Timer status (ON or OFF) is displayed. (For the Climate Ctrl timer

operation, see “Climate Ctrl. Timer” (P.4-35).)

ECO DRIVE REPORT

The ECO Drive Report appears for approximately 30 seconds when the power switch is placed in the OFF position after the vehicle was driven for more than 0.3 miles (500 m), and the scroll dial on the steering wheel is operated.

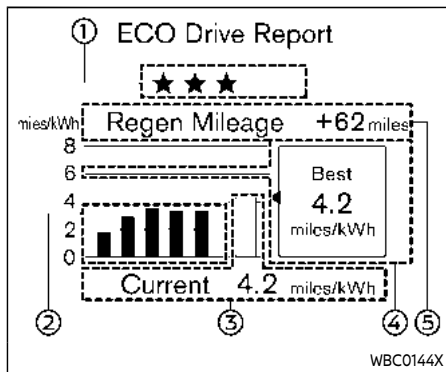

- ① ECO evaluation
The more economically you drive, the more ★ appears.
- ② Previous 5 times (History)
The average energy economy for the previous 5 times will be displayed.
- ③ Current energy economy
The most recent average energy economy will be displayed.
- ④ Best energy economy
The best energy economy in the history will be displayed.
- ⑤ Regenerated energy (mileage)
The amount of regenerated energy stored in the Li-ion battery in one trip will be displayed in terms of distance.

If the vehicle has been driven mostly on
2-50 **Instruments and controls**

downhill roads, more energy is regenerated. This may cause the regenerated energy (mileage) ④ to show longer distance than the vehicle was driven, or the current energy economy ② to show smaller value.

When the scroll dial on the steering wheel is pushed while the ECO Drive Report is shown, the display will be switched to the timer display. Either display will continue to be displayed for another 30 seconds when the button is operated. If the doors are locked after the power switch was placed in the OFF position, the display will turn off before the preset time.

In the Settings menu, you can set the ECO Drive Report not to appear when the power switch is placed in the OFF position. See "Settings" (P.2-25).

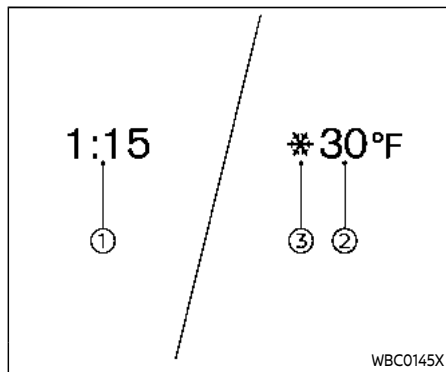

CLOCK AND OUTSIDE AIR TEMPERATURE

The clock ① is displayed on the upper side of the vehicle information display.

The outside air temperature ② is displayed on the lower side of the vehicle information display.

The displayed position varies depending on the meter screen view.

See "Changing the meter screen view" (P.2-6).

HEAD UP DISPLAY (HUD) (if so equipped)

Clock

For clock adjustment, see "Clock" (P.2-28) or the separate NissanConnect® Owner's Manual.

Outside air temperature

The outside air temperature is displayed in °F or °C in the range of -40 to 140°F (-40 to 60°C).

The outside air temperature mode includes a low temperature alert feature. If the outside air temperature is below 27°F (-3°C), the indicator ③ is displayed.

The outside temperature sensor is located in front of the radiator. The sensor may be affected by road or EV system heat, wind directions and other driving conditions. The display may differ from the actual outside temperature or the temperature displayed on various signs or billboards.

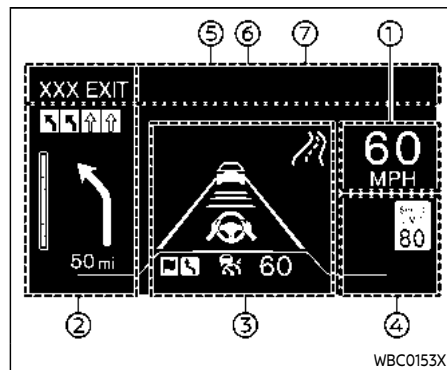

Example

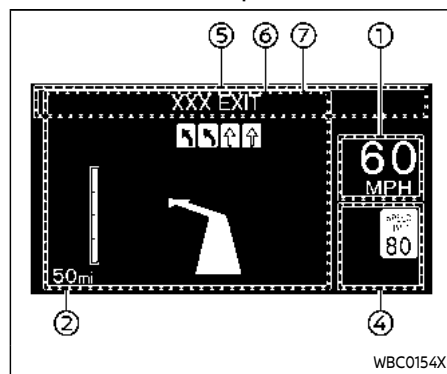

Example

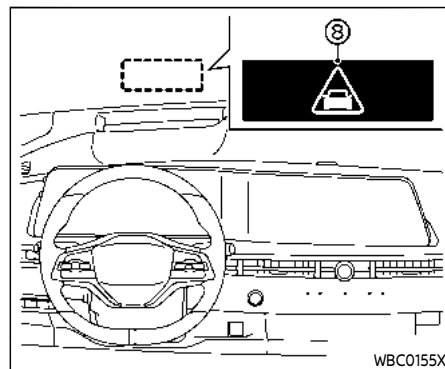

WARNING

- Failure to properly adjust the brightness and position of the displayed image may interfere with the driver's ability to see through the windshield, which could cause an accident leading to severe injury or death.
- Do not use the Head Up Display (HUD) for extended periods of time as that can cause you to not see other vehicles, pedestrians or objects, which could cause an accident leading to se-

vere injury or death.

The Head Up Display (HUD) can display one or more of the following features (if so equipped):

- ① Vehicle speed
- ② Navigation
- ③ Driving Assist
- ④ Traffic Sign
- ⑤ Audio
- ⑥ TEL/SMS
- ⑦ Message for Driver Assistance
- ⑧ Warning message



CAUTION

- Do not place any type of liquid on or near the projector. Doing so may cause malfunction of the equipment.

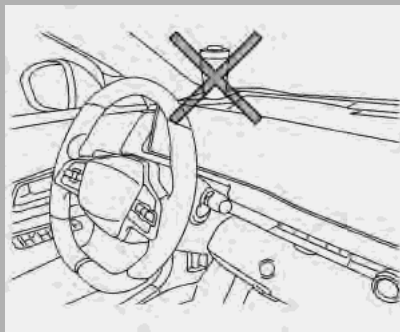

- Do not touch any internal parts of the projector. Doing so may cause malfunction of the equipment.
- To prevent scratches to the projector glass, do not place any sharp objects on or near the projector opening.
- Do not place any objects on the instrument panel which may obstruct the display of the HUD.
- For cleaning, use a soft cloth, dampened with water. Never use a rough cloth, alcohol, benzine, thinner or any kind of solvent or paper towel with a chemical cleaning agent. They will scratch or cause discoloration to the pro-

jector lens.

- Do not spray any liquid such as water on the projector lens. Spraying liquid may cause the system to malfunction.

NOTE:

- If you wear polarized sunglasses, the display may be difficult to see. Increase the brightness of the HUD in the vehicle information display or remove your sunglasses.
- Depending on weather conditions (rain, snow, sunlight, etc.), the display may be difficult to see.
- If the displayed image appears distorted, it is recommended you have the system checked by a NISSAN certified ARIYA dealer.
- The HUD has a special windshield to allow the image to be displayed clearly. If your windshield needs replacing, this should be completed by a NISSAN certified ARIYA dealer.
- For cleaning, use a soft clean dry cloth. If it cannot be removed, use a soft clean cloth, dampened with water. After that please use a soft clean close.

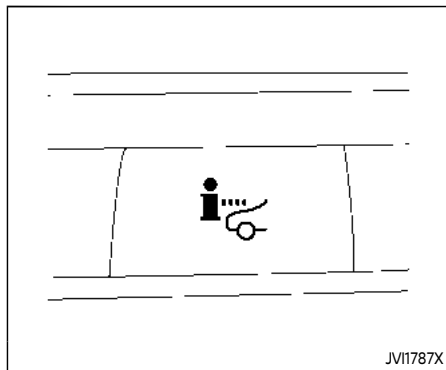

HOW TO USE THE HUD

To turn the HUD on, push the HUD switch.
To turn the HUD off, push the switch again.

If the HUD is turned off, it will remain off even if the vehicle is restarted.

The following settings can be changed in the vehicle information display:

- Brightness
- Height
- Rotation
- Contents selection
 - Navigation

- Driving Assist
- Speed Limit Sign
- Audio
- TEL/SMS

- Reset

NOTE:

Emergency information may display even if the HUD is turned off.

This product includes the following software.

- (1) Panasonic Corporation or software developed for Panasonic Corporation
- (2) Third-party software licensed to Panasonic Corporation
- (3) Open source software

Regarding (3) Open source software, it includes open source software (OSS), including various software to which license information applies.

Refer to the license web site at: <http://car.panasonic.jp/oss/j03l1nna>

Display brightness

The brightness of the display may be controlled in the vehicle information display. The brightness will also be adjusted automatically according to the exterior ambient lighting brightness.

Do not apply strong light to the sensor of Head Up Display. Doing so may cause a

malfunction.

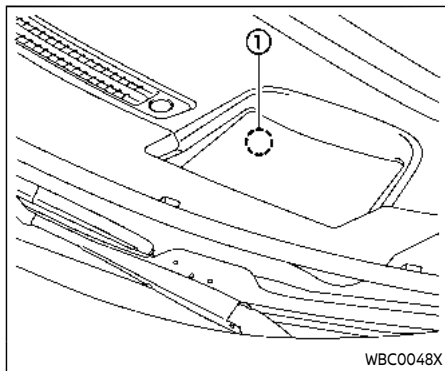

NOTE:

- The HUD has a built-in sensor ① that controls the brightness of the displayed image. If you block the sensor with an object, the display will darken, making it difficult to see.

**DRIVER ASSISTANCE/NAVIGATION/
TRAFFIC SIGN/AUDIO/TEL/SMS/
MESSAGE FOR DRIVER ASSISTANCE
LINKING**

The HUD will display Driver Assistance and navigation information.

The Driver Assistance display will show warning situations for the following systems if the vehicle is equipped with them:

- Automatic Emergency Braking (AEB) with Pedestrian Detection
- Intelligent Forward Collision Warning (I-FCW)
- Lane Departure Warning (LDW)
- Intelligent Lane Intervention (I-LI)
- Hands-free warning
- Lane Change Assist indicator (ProPILOT Assist 2.0)
- Route Assist indicator (ProPILOT Assist 2.0)

The Navigation System linking display will show the following items:

- Intersection names
- Arrows indicating turning direction
- Distance to the next intersection
- Recommended lane indicator

The Traffic Signs Recognition (TSR) system linking display will show the following items:

- Speed Limit Sign

The Audio System linking display will show the following items:

- Songs
- Radio stations

The TEL/SMS linking display will show the following item:

- Caller's name or phone number

The message linking display will show the

following item:

- ProPILOT Assist 2.0

WARNING MESSAGE (if so equipped)

When the following system is operated, the warning message appears on the Head Up Display (HUD).

- ProPILOT Assist 2.0
- Automatic Emergency Braking (AEB) with Pedestrian Detection system

For details, see "Vehicle information display warnings and indicators" (P.2-34).

SECURITY SYSTEMS

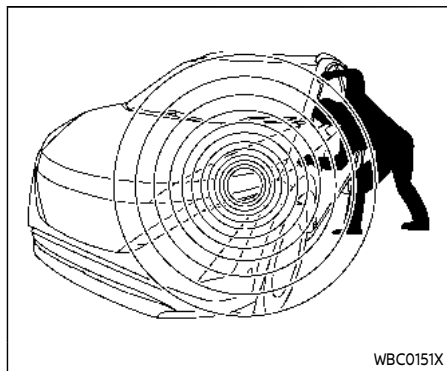

Your vehicle has two types of security systems, as follows:

- Vehicle security system
- NISSAN Vehicle Immobilizer System

VEHICLE SECURITY SYSTEM

The vehicle security system provides visual and audio alarm signals if someone opens the doors, hood and liftgate when the system is armed. It is not, however, a motion detection type system that activates when a vehicle is moved or when a vibration occurs.

The system helps deter vehicle theft but cannot prevent it, nor can it prevent the theft of interior or exterior vehicle components in all situations. Always secure

your vehicle even if parking for a brief period. Never leave your keys in the vehicle, and always lock it when unattended. Be aware of your surroundings, and park in secure, well-lit areas whenever possible.

Many devices offering additional protection, such as component locks, identification markers, and tracking systems, are available at auto supply stores and specialty shops. Your NISSAN certified ARIYA dealer may also offer such equipment. Check with your insurance company to see if you may be eligible for discounts for various theft protection features.

How to arm the vehicle security system

1. Close all windows. **The system can be armed even if the windows are open.**
2. Remove the keys from the vehicle.
3. Close all doors, hood and liftgate. Lock all doors. The doors can be locked with lock sensor (on the door handles), Intelligent Key, request switch.

Even when the driver and/or passengers are in the vehicle, the system will activate with all the doors, hood and liftgate locked with the power switch placed in the OFF position. When placing the power switch in the ON position, the system will be released.

Vehicle security system activation

The vehicle security system will give the following alarm:

- The headlights blink and the horn sounds intermittently.
- The alarm automatically turns off after approximately 30 seconds. However, the alarm reactivates if the vehicle is tampered with again.

The alarm is activated by:

- opening any doors, the hood or liftgate without using the Intelligent Key, the capacitive unlock sensor (on the door handles) or the request switch (even if the door is unlocked by releasing the door inside lock knob).

How to stop an activated alarm

The alarm stops by unlocking a door with the capacitive unlock sensor, pushing the UNLOCK  button on the Intelligent Key, pushing the request switch or placing the power switch in the ON position.

NISSAN VEHICLE IMMOBILIZER SYSTEM

The NISSAN Vehicle Immobilizer System will not allow the power switch to be placed in the READY to drive position without the use of the registered key.

If the EV system does not start using the

registered Intelligent Key, it may be due to interference caused by:

- Another Intelligent Key.
- Automated toll road device.
- Automated payment device.
- Other devices that transmit similar signals.

Start the EV system using the following procedure:

1. Remove any items that may be causing the interference away from the Intelligent Key.
2. Start the EV system again.

If this procedure allows the EV system to start, NISSAN recommends placing the registered Intelligent Key separate from other devices to avoid interference.

Statement related to section 15 of FCC rules for NISSAN Vehicle Immobilizer System (CONT ASSY-SMART KEYLESS)

FCC Notice:

For USA:

FCC ID : KR5HFM401

FCC ID : KR5HFM403

This device complies with Part 15 of the FCC Rules. Operation is subject to the following two conditions: (1) This device may not cause harmful interference, and (2) this device must accept any

interference received, including interference that may cause undesired operation.

Note: Changes or modifications not expressly approved by the party responsible for compliance could void the user's authority to operate the equipment.

For Canada:

IC ID : 7812D-HFM401

IC ID : 7812D-HDM403

This device contains licence-exempt transmitter(s)/receiver(s) that comply with Innovation, Science and Economic Development Canada's licence-exempt RSS(s). Operation is subject to the following two conditions: (1) This device may not cause interference. (2) This device must accept any interference, including interference that may cause undesired operation of the device.

WIPER AND WASHER SWITCH



WARNING

In freezing temperatures the washer solution may freeze on the windshield and obscure your vision which may lead to an accident. Warm windshield with the defroster before you wash the windshield.



CAUTION

- Do not operate the washer continuously for more than 30 seconds.
- Do not operate the washer if the reservoir tank is empty.
- Do not fill the window washer reservoir tank with washer fluid concentrates at full strength. Some methyl alcohol based washer fluid concentrates may permanently stain the grille if spilled while filling the window washer reservoir tank.
- Pre-mix washer fluid concentrates with water to the manufacturer's recommended levels before pouring the fluid into the window washer reservoir tank. Do

not use the window washer reservoir tank to mix the washer fluid concentrate and water.

If the windshield wiper operation is interrupted by snow or ice, the wiper may stop moving to protect its motor. If this occurs, turn the wiper switch to the OFF position and remove the snow or ice that is on and around the wiper arms. In approximately 1 minute, turn the switch on again to operate the wiper.

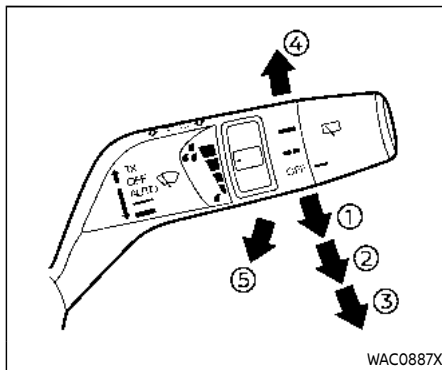

Type A

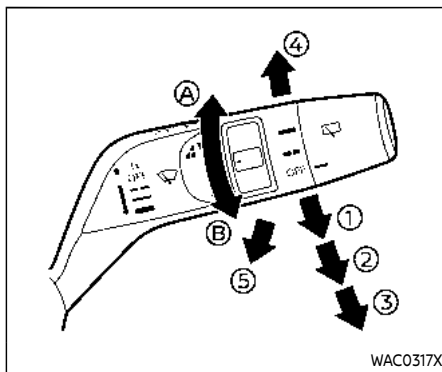

Type B

WINDSHIELD WIPER AND WASHER OPERATION

The windshield wiper and washer operates when the power switch is in the ON position.

Push the lever down to operate the wiper at the following speed:

① Type A: AUTO — see "Rain-sensing auto wiper system" (P.2-58).

Type B: Intermittent — intermittent operation can be adjusted by turning the knob toward Ⓐ (Faster) or Ⓑ (Slower). Also, the intermittent operation speed varies in accordance with the vehicle speed. (For example, when the vehicle speed is high, the intermittent operation speed will be faster.)

② Low — continuous low speed operation

③ High — continuous high speed operation

If the power switch is placed in the OFF position while the wiper operates in the high speed position, the wiper will not operate the next time the power switch is placed in the ON position. To operate the wiper, move the lever to any position other than high speed.

Push the lever up ④ to have one sweep operation of the wiper.

Pull the lever toward you ⑤ to operate the washer. Then the wiper will also operate several times.

NOTE:

The Speed Dependent feature may be disabled. For additional information, refer to "Vehicle Settings" (P.2-28).



CAUTION

Do not operate the windshield wiper while the wiper arm is pulled up. The wiper arm may be damaged.

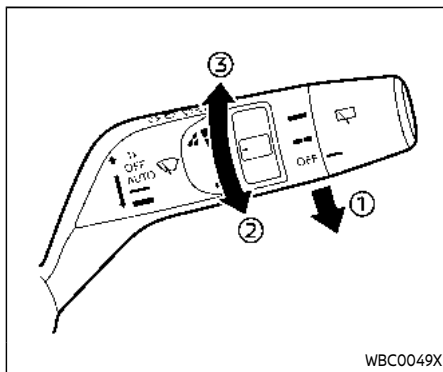

RAIN-SENSING AUTO WIPER SYSTEM (if so equipped)

The rain-sensing auto wiper system can automatically turn on the wipers and adjust the wiper speed depending on the rainfall and the vehicle speed by using the rain sensor located on the upper part of the windshield.

To set the rain-sensing auto wiper system, push the lever down to the "AUTO" position ①. The wiper will sweep once while the power switch is in the "ON" position.

The rain sensor sensitivity level can be adjusted by turning the knob toward ② (Low) or ③ (High).

- High — High sensitive operation
- Low — Low sensitive operation

To turn the rain-sensing auto wiper system off, push up the lever to the "OFF" position, or pull down the lever to the other.



CAUTION

Do not touch the rain sensor and around it when the wiper switch is in the "AUTO" position and the power switch is in the "ON" position. The wipers may operate unexpectedly and cause an injury or may damage a wiper.

- The rain-sensing auto wipers are intended for use during rain. If the switch is left in the "AUTO" position, the wipers may operate unexpectedly when dirt, fingerprints, oil film or insects are stuck on or around the sensor. The wipers may also operate when exhaust gas or moisture affect the rain sensor.
- When the windshield glass is coated with water repellent, the speed of the rain-sensing auto wipers may be higher even though the amount of the rainfall

is small.

- Be sure to turn off the rain-sensing auto wiper system when you use a car wash.
- The rain-sensing auto wipers may not operate if rain does not hit the rain sensor even if it is raining.
- Using genuine wiper blades is recommended for proper operation of the rain-sensing auto wiper system. (See "Windshield wiper blades" (P.8-8) for wiper blade replacement.)

REAR WINDOW WIPER AND WASHER OPERATION



WARNING

In freezing temperatures the washer solution may freeze on the rear window glass and obscure your vision. Warm the rear window with the defroster before you wash the rear window.



CAUTION

- Do not operate the washer continuously for more than 30 seconds.
- Do not operate the washer if the reservoir tank is empty.
- Do not fill the window washer reservoir tank with washer fluid concentrates at full strength. Some methyl alcohol based washer fluid concentrates may permanently stain the grille if spilled while filling the window washer reservoir tank.
- Pre-mix washer fluid concentrates with water to the manufacturer's recommended levels before pouring the fluid into the window washer reservoir tank. Do not use the window washer reservoir tank to mix the washer fluid concentrate and water.

If the rear window wiper operation is interrupted by snow or ice, the wiper may stop moving to protect its motor. If this occurs, turn the wiper switch to the OFF position and remove the snow or ice that is on and around the wiper

arms. In approximately 1 minute, turn the switch on again to operate the wiper.

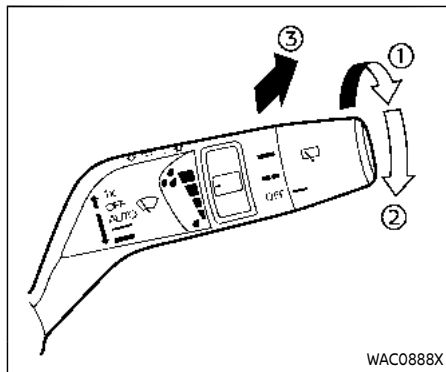

Example

The rear window wiper and washer operate when the power switch is in the ON position.

Turn the switch clockwise from the OFF position to operate the wiper.

- ① Intermittent (INT) – intermittent operation (not adjustable)
- ② Low (ON) – continuous low speed operation

Push the switch forward ③ to operate the washer. Then the wiper will also operate several times.

Reverse Link feature:

When the windshield wiper switch is on, moving the shift lever to the R (Reverse)

position will operate the rear window wiper.

NOTE:

The Reverse Link feature may be disabled. For additional information, refer to “Vehicle Settings” (P.2-28).

REAR WINDOW AND OUTSIDE MIRROR DEFROSTER SWITCH

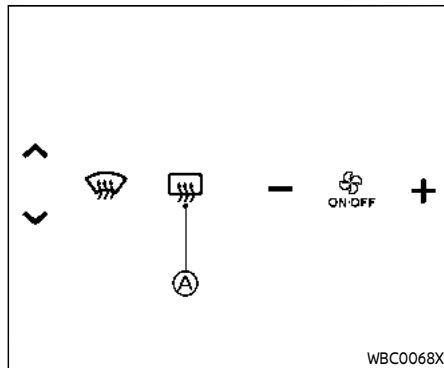

To defog/defrost the rear window glass and outside mirrors, start the EV system and push the switch on. The indicator light Ⓐ will illuminate. Push the switch again to turn the defroster off.

It will automatically turn off in approximately 20 minutes.



CAUTION

When operating the defroster continuously, be sure to start the EV system. Otherwise, it may cause the 12-volt battery to discharge.

When cleaning the inner side of the

rear window, be careful not to scratch or damage the rear window defroster.

HEADLIGHT AND TURN SIGNAL SWITCH

HEADLIGHT SWITCH



CAUTION

Use the headlights with the EV system running to avoid discharging the vehicle battery.

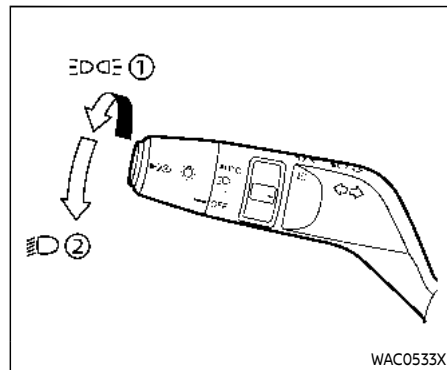

Example

Lighting

Type A (if so equipped):

- ① Rotate the switch to the **EDGE** position, and the front parking, tail, license plate, and instrument panel lights will come on.
- ② Rotate the switch to the **HEADLIGHT** position, and the headlights will come on and all the other lights remain on. The daytime running light will turn off.

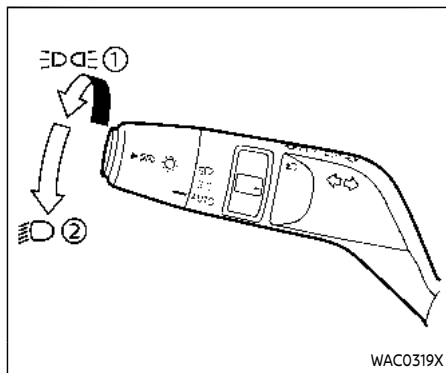

Example

Type B (if so equipped):

- ① Rotate the switch to the OFF position, and the front parking, tail, license plate, and instrument panel lights will come on. The Intelligent Auto Headlight system will also be set in this position.
- ② Rotate the switch to the AUTO position, and the headlights will come on and all the other lights remain on. The daytime running light will turn off.

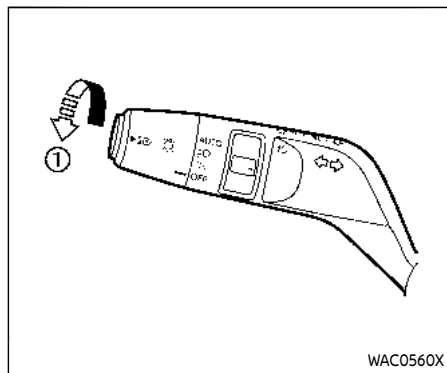

Example

Intelligent Auto Headlight system

Type A (if so equipped):

The Intelligent Auto Headlight system allows the headlights to be set so they turn on and off automatically.

To set the Intelligent Auto Headlight system:

1. Make sure the headlight switch is in the AUTO position ①.
2. Place the power switch in the ON position.
3. The Intelligent Auto Headlight system automatically turns the headlights on and off.

To turn the Intelligent Auto Headlight system off, turn the switch to the OFF, PARK or HEAD position.

The Intelligent Auto Headlight system can turn on the headlights automatically when it is dark and turn off the headlights when it is light.

The headlights will also be turned on automatically at twilight or in rainy weather (when the windshield wiper is operated continuously).

If the power switch is placed in the OFF position and one of the doors is opened and this condition is continued, the headlights remain on for 5 minutes.

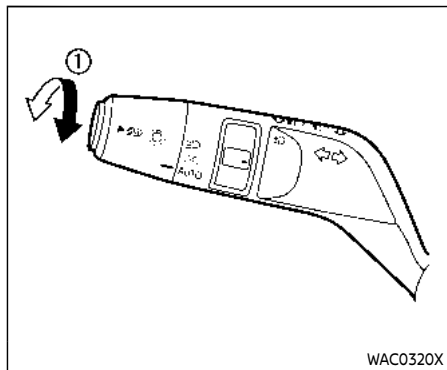

Example

Type B (if so equipped):

The Intelligent Auto Headlight system allows the headlights to be set so they turn on and off automatically.

To set the Intelligent Auto Headlight system:

1. Make sure the headlight switch is in the **OFF** or **AUTO** position ①.
2. Place the power switch in the **ON** position.
3. The Intelligent Auto Headlight system automatically turns the headlights on and off.

To turn the Intelligent Auto Headlight system off, turn the switch to the 

position.

The Intelligent Auto Headlight system can turn on the headlights automatically when it is dark and turn off the headlights when it is light.

If the power switch is placed in the **ON** position when the parking brake is applied, the headlights remain off.

With the **AUTO** position selected, the headlights turn off when the power switch is placed in the **OFF** position, the shift position is placed in the **P** (Park) position or the parking brake is applied. (The front parking, tail, license plate, and instrument panel lights are on.)

The headlights will also be turned on automatically at twilight or in rainy weather (when the windshield wiper is operated continuously).

With the **AUTO** position selected (headlights are on), if the power switch is placed in the **OFF** position and one of the doors is opened and this condition is continued, the headlights remain on for 5 minutes.

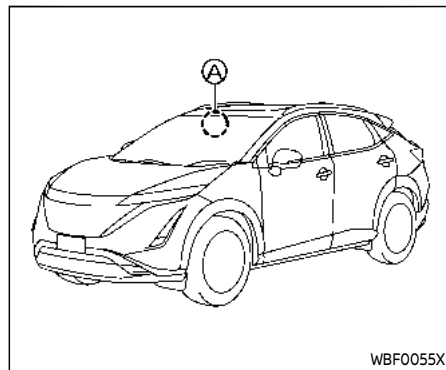

Type A (if so equipped)

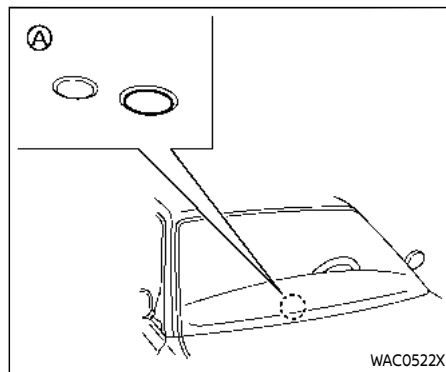

Type B (if so equipped)

Be sure not to put anything on top of the sensor  located in front of the inside mirror (or located on the top of the instrument panel, depending on the models). The sensor controls the Intelligent Auto Headlight; if it is covered, the sensor reacts as if it is dark and the headlights will illuminate.

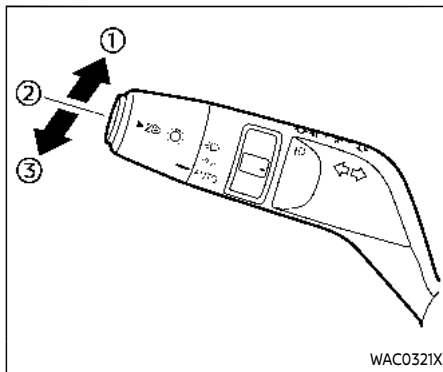

Example

- ① To select the high beam, push the lever forward and release it. The high beam lights come on and the  light illuminates.
- ② Pull the lever back and release it to select the low beam.
- ③ To flash the headlights when the high beam is not selected, pull the lever towards the rear position. To flash the headlights when the high beam is selected, pull the lever twice towards the rear position.

Headlight beam select

Automatic headlights off delay:

You can keep the headlights on for up to 180 seconds after you push the power

switch to OFF and open any door then close all the doors. You can adjust the period of the automatic headlights off delay from 0 seconds (OFF) to 180 seconds. The factory default setting is 45 seconds.

High beam assist

The high beam assist system will operate when the vehicle is driven at speeds of approximately 19 MPH (30 km/h) and above. If an oncoming vehicle or leading vehicle appears in front of your vehicle when the headlight high beam is on, the headlight will be switched to the low beam automatically.

Precautions on high beam assist:



WARNING

- The high beam assist system is a convenience but it is not a substitute for safe driving operation. The driver should remain alert at all times, ensure safe driving practices and switch the high beams and low beam manually when necessary.
- The high beam or low beam may not switch automatically under the following conditions. Switch

the high beam and low beam manually.

- During bad weather (rain, fog, snow, wind, etc.).
- When a light source similar to a headlight or tail light is in the vicinity of the vehicle.
- When the headlights of the oncoming vehicle or the leading vehicle are turned off, when the color of the light is affected due to foreign materials on the lights, or when the light beam is out of position.
- When there is a sudden, continuous change in brightness.
- When driving on a road that passes over rolling hills, or a road that has level differences.
- When driving on a road with many curves.
- When a sign or mirror-like surface is reflecting intense light towards the front of the vehicle.
- When the container, etc. being towed by a leading vehicle is reflecting intense light.

- When a headlight on your vehicle is damaged or dirty.
- When the vehicle is leaning at an angle due to a punctured tire, being towed, etc.
- The timing of switching the low beam and high beam may change under the following situations.
 - The brightness of the headlights of the oncoming vehicle or leading vehicle.
 - The movement and direction of the oncoming vehicle and the leading vehicle.
 - When only one light on the oncoming vehicle or the leading vehicle is illuminated.
 - When the oncoming vehicle or the leading vehicle is a two-wheeled vehicle.
 - Road conditions (incline, curve, the road surface, etc.).
 - The number of passengers and the amount of cargo.

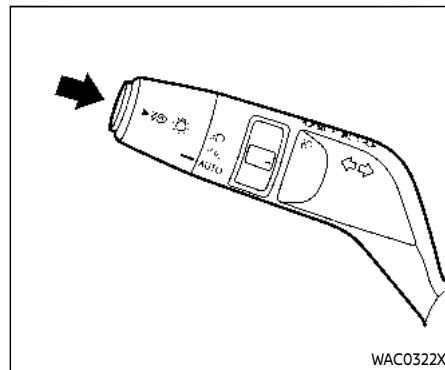

Example

High beam assist operations:

To activate the high beam assist system, push the switch as illustrated with the AUTO position (or Dd position, depending on the model). The high beam assist indicator light in the meter will illuminate while the headlights are turned on.

If the high beam assist indicator light does not illuminate in the above condition, it may indicate that the system is not functioning properly. It is recommended you have the system checked by a NISSAN certified ARIYA dealer.

When the vehicle speed lowers to less than approximately 13 MPH (20 km/h), the

headlight remains the low beam.

To turn off the high beam assist system, push the switch again.

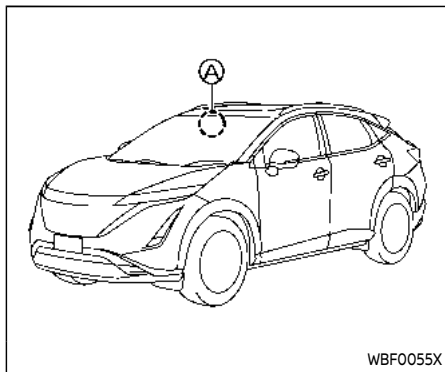





Ambient image sensor maintenance:

The ambient image sensor (A) for the high beam assist system is located in front of the inside mirror. To keep the proper operation of the high beam assist system and prevent a system malfunction, be sure to observe the following:

- Always keep the windshield clean.
- Do not attach a sticker (including transparent material) or install an accessory near the ambient image sensor.
- Do not strike or damage the areas around the ambient image sensor. Do not touch the sensor lens that is located on the ambient image sensor.

If the ambient image sensor is damaged due to an accident, it is recommended you contact a NISSAN certified ARIYA dealer.

Battery saver system

- When the headlight switch is in the  or  position while the power switch is in the ON position, the lights will automatically turn off within a period of time after the power switch has been placed in the OFF position.
- When the headlight switch remains in the  or  position after the lights automatically turn off, the lights will turn on when the power switch is placed in the ON position.



CAUTION

- **When you turn on the headlight switch again after the lights automatically turn off, the lights will not turn off automatically. Be sure to turn the light switch to the OFF (if so equipped) or AUTO position when you leave the vehicle for extended periods of time, otherwise the 12-volt battery will be discharged.**

- **Never leave the light switch on when the EV system is not running for extended periods of time even if the headlights turn off automatically.**

Daytime Running Light (DRL) system

The LED Daytime Running Lights (DRL) automatically illuminate when the EV system is started and the parking brake is released. The LED DRL operate with the headlight switch in the OFF (if so equipped), OFF , or AUTO (when the headlights are off) position. When you turn the headlight switch to the D position for full illumination, the LED lights switch from LED DRL to the park function.

Type A: If the parking brake is applied before the EV system is started, the LED DRL do not illuminate. The LED DRL illuminate when the parking brake is released. This feature will work in the OFF , AUTO or OFF position. The LED DRL will remain on until the power switch is placed in the OFF position.

Type B: If the parking brake is applied before the EV system is started, the LED DRL do not illuminate. The LED DRL illuminate when the parking brake is released. This feature will work in the

AUTO or OFF position. The LED DRL will remain on until the power switch is placed in the OFF position.



WARNING

When the LED DRL system is active with the headlight switch in the OFF position (if so equipped), tail lights on your vehicle are not on. It is necessary at dusk to turn on your headlights. Failure to do so could cause an accident injuring yourself and others.

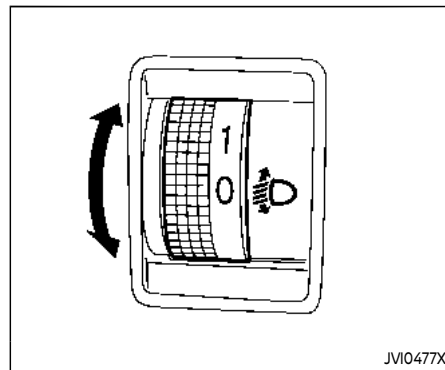

JVI0477X

HEADLIGHT AIMING CONTROL

The headlight aiming control operates when the power switch is in the ON position and the headlight is on to allow the headlight axis to be adjusted according to the driving conditions.

When driving with no heavy load/luggage or driving on a flat road, select the normal position "O".

If the number of occupants and load/luggage in the vehicle changes, the headlight axis may become higher than normal.

If the vehicle is traveling on a hilly road, the headlights may directly shine on the rearview and outside mirrors of a vehicle

ahead or the windshield of an oncoming vehicle, which may obscure other drivers' vision.

To adjust to the proper aiming height, turn the switch accordingly. The higher the number, designated on the switch, the lower the headlight axis.

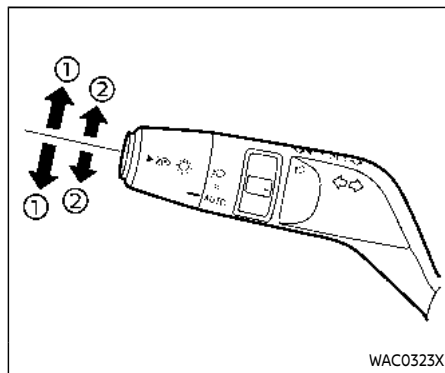

Example

TURN SIGNAL SWITCH

① Turn signal

Move the lever up or down to signal the turning direction. When the turn is completed, the turn signals cancel automatically.

Models with ProPILOT Assist 2.0:

The lever will return to the neutral position after moving and then releasing it. To cancel the turn signals, move the lever to the opposite direction.

② Lane change signal

Move the lever up or down until the turn signal begins to flash, but the lever does not latch, to signal a lane change. Hold the lever until the lane change is completed.

Move the lever up or down until the turn signal begins to flash, but the lever does not latch, and release the lever. The turn signal will automatically flash three times.

Choose the appropriate method to signal a lane change based on road and traffic conditions.

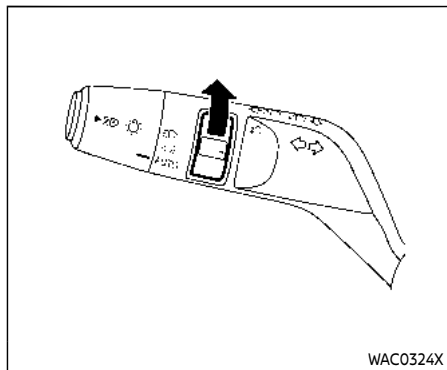

Front fog lights (example)

FOG LIGHT SWITCH (if so equipped)

Front fog lights

To turn the fog lights on, turn the fog light switch to the  position when the headlight is on.

To turn the fog lights on with the headlight switch in the AUTO position, the headlights must be on, then turn the fog light switch to the  position.

To turn them off, turn the fog light switch to the OFF position.

The fog lights automatically turn off when the high beam headlights are selected.

EMBLEM LIGHT

Regardless of headlight switch position, the emblem light illuminates when the power switch is in the ON position, the welcome light is activated, or the door is locked. The light turns off when the power switch is placed in the OFF position.

HORN

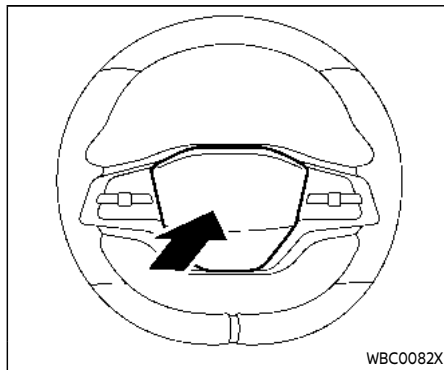

To sound the horn, push the center pad area of the steering wheel.



WARNING

Do not disassemble the horn. Doing so could affect proper operation of the supplemental front air bag system. Tampering with the supplemental front air bag system may result in serious personal injury.

HEATED STEERING WHEEL (if so equipped)

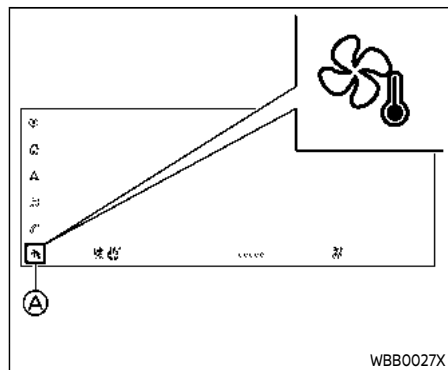

Example

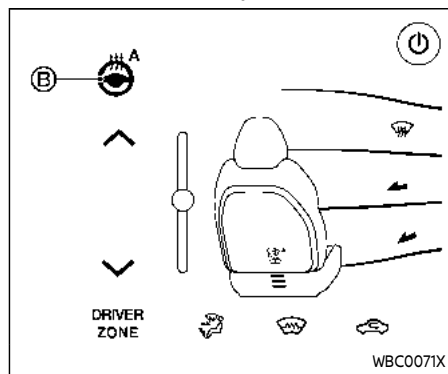

WBB0027X



Example

WBC0071X

The control keys are displayed on the touch screen display.

1. Start the EV system.
2. To display the air conditioner screen, touch the  key (A) on the touch screen display.
3. Touch the  key (B) to select the mode.
 - ① Auto mode (orange)
 - ② Manual mode (orange)
 - ③ Off (gray)

If the surface temperature of the steering wheel is below 86 to 104°F (30 to 40°C), the system will heat the steering wheel and cycle off and on to maintain a temperature above 86 to 104°F (30 to 40°C). The indicator light will remain on as long as the system is on.

In the AUTO mode, the temperature control intensity level can be selected by the touch screen display. (See "Air conditioner settings" (P.4-33).)

The heated steering wheel system is automatically turned off after 30 minutes.

HEATED SEATS (if so equipped)

WARNING

Do not use or allow occupants to use the seat heater if you or the occupants cannot monitor elevated seat temperatures or have an inability to feel pain in body parts that contact the seat. Use of the seat heater by such people could result in serious injury.

CAUTION

- The 12-volt battery could run down if the seat heater is operated while the EV system is not running.
- Do not use the seat heater for extended periods or when no one is using the seat.
- Do not put anything on the seat which insulates heat, such as a blanket, cushion, seat cover, etc. Otherwise, the seat may become overheated.
- Do not place anything hard or heavy on the seat or pierce it with a pin or similar object. This may result in damage to the heater.

- Any liquid spilled on the heated seat should be removed immediately with a dry cloth.
- When cleaning the seat, never use gasoline, thinner, or any similar materials.
- If any malfunctions are found or the heated seat does not operate, turn the switch off and have the system checked. It is recommended you visit a NISSAN certified ARIYA dealer for this service.

NOTE:

The heated seats consume less power than the heater and can be used to either help extend driving range by reducing heater use or to maximize comfort by supplementing the heater.

The front and rear seats are warmed by built-in heaters. The control keys are displayed on the touch screen display and the switches are located on the back of the center console box (if so equipped), and can be operated independently of each other.

The heater is controlled by a control module, automatically adjusting the heat level to maintain comfort according to the selected heat range.

The temperature control intensity level

can be selected by the touch screen display. See "Air conditioner settings" (P.4-33).

When the vehicle's interior is warmed, or before you leave the vehicle, be sure to turn off the seat heater.

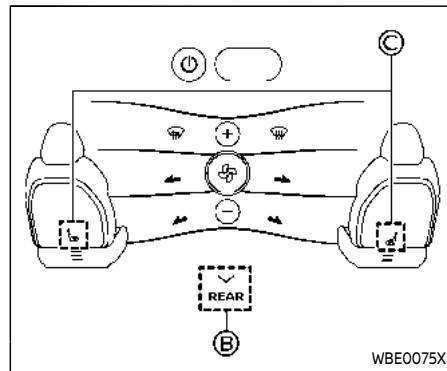
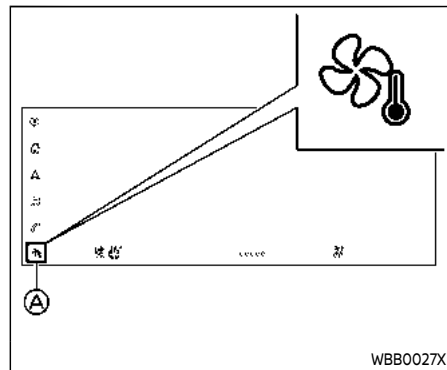

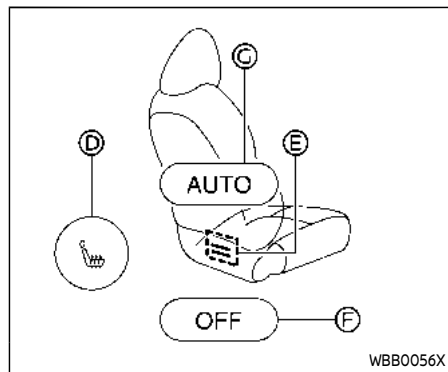

OPERATION WITH TOUCH SCREEN DISPLAY

1. Start the EV system.
2. To display the climate control screen, touch the key **A** on the touch screen display.
To select the rear seat, touch the "REAR" key **B**.
3. Touch the or key **C**.
4. Touch the key **D** to select the desired heat range.
 - For high heat, touch the key once.
 - For medium heat, touch the key twice.

- For low heat, touch the key three times.
- The indicator **E** illuminates depending on the heat level.

You can also select the AUTO mode by touching the "AUTO" key **C**.

For the AUTO mode, the temperature control intensity level can be adjusted. See "Air conditioner settings" (P.4-33).

5. To turn off the heater, touch the "OFF" key **F**.

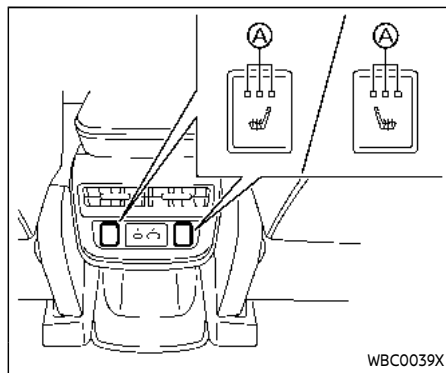

Rear

OPERATION WITH SWITCH (for rear outboard seats)

1. Start the EV system.
2. Push the heated seat switch and select the desired heat range.
 - For high heat, push the switch once.
 - For medium heat, push the switch twice.
 - For low heat, push the switch three times.
 - The indicator light **A** on the switch will illuminate depending on the heat level when the heater is on.

CLIMATE CONTROLLED SEATS (if so equipped)

- To turn off the heater, push the heated seat switch until the indicator light turns off.

NOTE:

The climate controlled seats consume less power than the heater and air conditioner and can be used to either help extend driving range by reducing heater and air conditioner use or to maximize comfort by supplementing the heater and air conditioner.

The climate controlled seats warm the front seats by built-in heaters or cool the front seats by ventilating the seat surface. The control keys are displayed on the touch screen display and can be operated independently of each other.

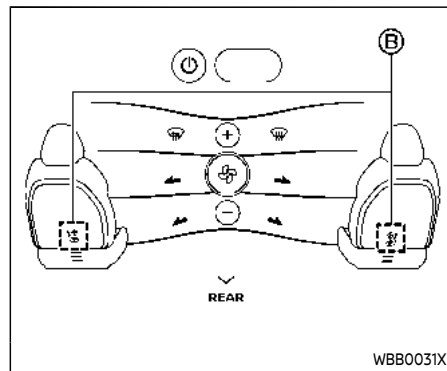
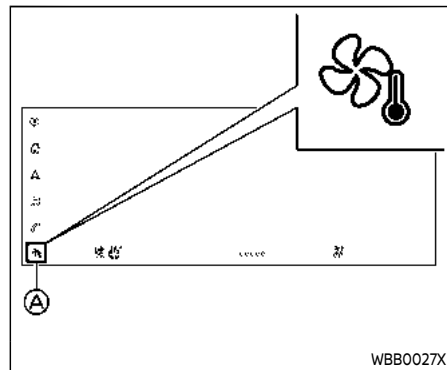

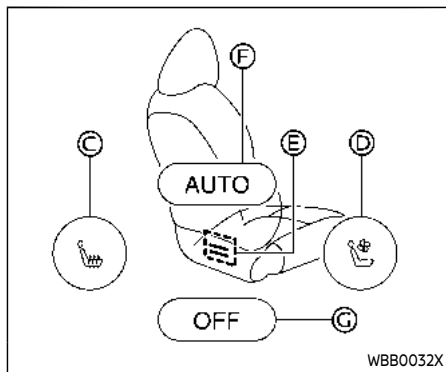

1. Start the EV system.
2. To display the climate control screen, touch the key **A** on the touch screen display.
3. Touch the or key **B**.
4. To warm the seat, touch the key **C** (once, twice or three times). The indicator **E** illuminates in orange depending on the heat level.

To ventilate the seat, touch the key **D** (once, twice or three times). The indicator **F** illuminates in blue depending on the ventilation level.

You can also select the AUTO mode by touching the "AUTO" key **E**.

For the AUTO mode, the temperature control intensity level can be adjusted. See "Air conditioner settings" (P.4-33).

5. To turn off, touch the "OFF" key **G**.

When the vehicle's interior is warmed or cooled, or before you leave the vehicle, be sure to turn off the climate controlled seats.

To check the air filters for the climate controlled seats, it is recommended you visit a NISSAN certified ARIYA dealer.



WARNING

Do not use or allow occupants to use the climate controlled seats if you or the occupants cannot monitor seat temperatures or have an inability to feel pain in those body parts in contact with the seat. Use of the climate controlled seats by such people could result in serious injury.



CAUTION

- **The 12-volt battery could run down if the climate controlled seat is operated while the power switch is not in the READY to drive**

position.

- **Do not use the climate controlled seat for extended periods or when no one is using the seat.**
- **Do not put anything on the seat which insulates heat, such as a blanket, cushion, seat cover, etc. Otherwise, the seat may become overheated.**
- **Do not place anything hard or heavy on the seat or pierce it with a pin or similar object. This may result in damage to the climate controlled seat.**
- **Any liquid spilled on the seat should be removed immediately with a dry cloth.**
- **The climate controlled seat has an air filter. Do not operate climate controlled seat without an air filter. This may result in damage to the system.**
- **When cleaning the seat, never use gasoline, thinner, or any similar materials.**
- **If any malfunctions are found or the climate controlled seat does not operate, turn the switch off and have the system checked. It is recommended you visit a**

NISSAN certified ARIYA dealer for this service.

STEERING ASSIST SWITCH

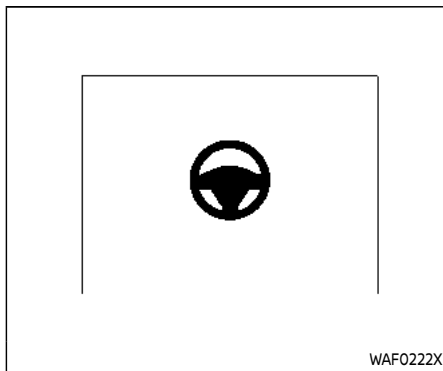

The Steering Assist switch is used to temporarily turn on and off the Steering Assist system.

You can also use the "Driver Assistance" menu in the vehicle information display to turn on and off the Steering Assist system. (See "Settings" (P.2-25).)

The Steering Assist system controls the steering system to help keep your vehicle near the center of the lane when driving. (See "ProPILOT Assist Systems" (P.5-82).)

REAR DOOR ALERT

The Rear Door Alert system functions under certain conditions to indicate there may be an object or passenger in the rear seat(s). Check the seat(s) before exiting the vehicle.

The Rear Door Alert system is initially disabled. The driver can enable the system using the vehicle information display. (See "Vehicle Settings" (P.2-28).)

When the system is enabled:

- The system is activated when a rear door is opened and closed. When the vehicle is started and the system is activated, a visual message appears in the vehicle information display. (See "75. Rear Door Alert is activated indicator" (P.2-43).)
- If a rear door is opened and closed but the vehicle is not driven, the system will not be activated. A rear door must be opened and closed and the car driven for the system to activate.
- The time interval to activate the system between when the rear door is opened and closed and the vehicle is started is about 10 minutes. A longer interval does not indicate a malfunction.

When the Rear Door Alert system is activated:

- When the driver puts the vehicle in the P (Park) position, a notification message appears in the vehicle information display with the options to "Dismiss Message" or "Disable Alert" if desired.
 - Select "Disable Alert" to temporarily disable for that stop.
 - No selection or "Dismiss Message" will keep the alert enabled for that stop.
- If the alert is enabled when a driver exits the vehicle, a message will appear in the vehicle information display that states "Check Rear Seat for All Articles."
If "Horn & Alert" setting is selected:
 - An audible horn sound will occur after a short time unless a rear door is opened and closed within a short time to deactivate the alert.
 - If the doors are locked before the alert is deactivated by opening a rear door, the horn will sound.
 - If the liftgate is opened before a rear door is opened, the horn will be delayed until after the liftgate is closed.

NOTE:

If "Alert Only" setting is selected, the message alert will still be shown in the vehicle information display but the horn will not sound.



WARNING

- **If the driver selects "Disable Alert", no audible alert will be provided regardless of rear door open/close status.**
- **There may be times when there is an object or passenger in the rear seat(s) but the audible alert does not sound. For example, this may occur if rear seat passengers enter or exit the vehicle during a trip.**
- **The system does not directly detect objects or passengers in the rear seat(s). Instead, it can detect when a rear door is opened and closed, indicating that there may be something in the rear seat(s).**

NOTE:

There may be times when the horn sounds but there are no objects or passengers in the rear seat(s).

(See "75. Rear Door Alert is activated indicator" (P.2-43).)

POWER OUTLETS

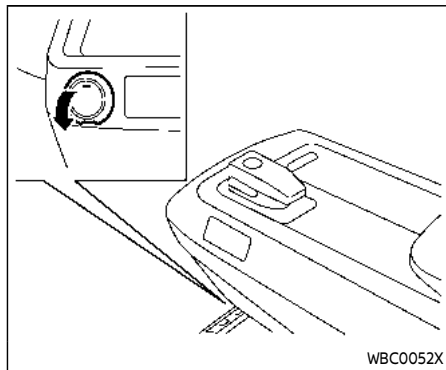

The power outlet is located in the front lower part of the center console.



CAUTION

- The outlet and plug may be hot during or immediately after use.
- Do not use with accessories that exceed a 12 volt, 120W (10A) power draw. Do not use double adapters or more than one electrical accessory.
- Use power outlet with the power switch in the ON or READY to drive position to avoid discharging the

12-volt battery.

- Avoid using power outlet when the air conditioner, headlights or rear window defroster is on.
- This power outlet is not designed for use with a cigarette lighter unit.
- Push the plug in as far as it will go. If good contact is not made, the plug may overheat.
- Before inserting or disconnecting a plug, be sure the electrical accessory being used is turned OFF.
- When not in use, be sure to close the cap. Do not allow water or any liquid to contact the outlet.

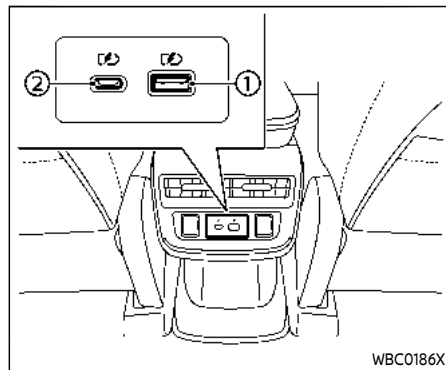

- ① Type-A USB charging connector
- ② Type-C USB charging connector

USB (Universal Serial Bus) CHARGING CONNECTOR

The USB charging connector is located on the back of the center console box.

The USB charging connector can be used only for charging an external device.

Connect a USB device into the connector. Charging will start automatically (maximum output up to 5 volt, 12W, 2.4A).

The external device will be charged continuously while the power switch is in the ON position.

Some mobile devices cannot be charged

depending on their specifications.

NOTE:

For best results, it is recommended to use the manufacturer cables, which are sold separately. A USB Type-A to USB Type-C adapter can also be purchased separately; however, results may vary.

CAUTION

- Do not force a USB device into the connector. Depending on the USB connector, inserting the USB device tilted or upside down may damage the connector. Make sure that the USB device is connected correctly into the connector.
- Do not use a reversible USB cable. Using the reversible USB cable may damage the connector.

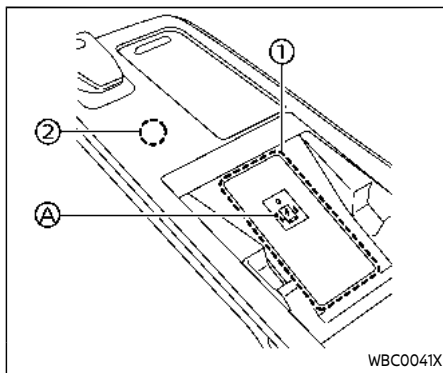

1. Charging pad
2. Indicator

WIRELESS CHARGER (if so equipped)

The wireless charger is located in the center console box. Lay the smartphone on the pad of the wireless charger. Charging will start automatically. The smartphone will be charged continuously while the power switch is in the ON position.

WARNING

- Never put metallic materials between the wireless charger and a smartphone.
- Those who use a pacemaker or other medical equipment should contact the electric medical equipment manufacturer for the possible influences before use.
- Never put cloth over the smartphone during charging process.
- Never charge a smartphone when it is wet.
- Never put metallic materials or small goods such as a cigarette lighter, Intelligent Key or memory drive.

CAUTION

- Do not put an RFID/NFC/credit card between the wireless charger and a smartphone. This could cause data corruption in the card.
- Do not use the wireless charger with dust accumulated or dirt on the pad.

- Do not hit the surface of the wireless charger.
- Do not spill liquid (water, drinks, etc.) on the charging pad.
- Do not use grease, oil or alcohol for cleaning charging pad.

Wireless charger Indicator

The indicator  will illuminate in orange when the charging process is started.

When the charging has completed, the indicator illuminates in green.

If a malfunction occurs or the charging process has stopped, the indicator will blink in orange for 8 seconds then turn off.

Operation of the wireless charger

To use the wireless charger, it is necessary to seat the smartphone well within the charging pad. To maximize charging performance, ensure the smartphone is fully seated on the center of the charging pad over the "Qi" logo . Because the location of the power receiver may vary depending on the smartphone, you will need to try and find the area that suits your smartphone.

Because some smartphone cases or accessories may adversely affect charging,

remove them before wireless charging. Turn off the vibration function of the smartphone before wireless charging.

NOTE:

- Only a Qi compatible smartphone can be used.
- The smartphone or the wireless charger may be warmed during charging process and the charging may stop by the protection function of the smartphone or the wireless charger. This is not a malfunction. If this occurs, restart charging after the smartphone or the wireless charger cooled down. The indicator will blink in orange then turn off.
- The wireless charging process may be stopped by the status of the smartphone (battery temperature, etc.).
- If a radio noise interference occurs during charging process, put the smartphone onto the center ("Qi" logo) position of the wireless charger.
- The wireless charging process will stop during process of searching the Intelligent Key. Therefore, please make sure all doors are closed to being charging process begins.

- The wireless charging process will not be started when a USB (Universal Serial Bus) cable is connected to the smartphone. The indicator may illuminate in orange or blink if the smartphone is put on the wireless charger with a USB cable connected. However, charging is not performed.
- Depending on the type of the smartphone, the indicator may remain illuminated in orange even when the charging process has been completed.

FCC ID: BEJWC500MNM

IC: 2703H-WC500MNM

This device complies with part 15 of the FCC Rules and RSS-Gen of IC Rules.

Operation is subject to the following two conditions:

(1) This device may not cause harmful interference, and

(2) This device must accept any interference received, including interference that may cause undesired operation.

Changes or modifications not expressly approved by the party responsible for compliance could void the user's authority to operate the equipment.

RF Radiation Exposure Statement: This equipment complies with FCC RF Radia-

tion exposure limits set forth for an uncontrolled environment.

This device and its antenna must not be co-located or operating in conjunction with any other antenna or transmitter.

This equipment should be installed and operated with a minimum distance of 15cm between the radiator and your body.

ISED Compliance Statement

This device complies with RSS-Gen of IC Rules

Operation is subject to the following two conditions:

(1) This device may not cause harmful interference, and

(2) This device must accept any interference received, including interference that may cause undesired operation.

Changes or modifications made to this device, not expressly approved by LG Vehicle Components Company, will void the user's authority to operate the equipment.

ISED RF Radiation Exposure Statement:
This equipment complies with ISED RF Radiation exposure limits set forth for an uncontrolled environment. This device and its antenna must not be co-

located or operating in conjunction with any other antenna or transmitter. This equipment should be installed to operate with a minimum distance of 15cm between the radiator and the end-user's body and arms.

EMERGENCY CALL (SOS) BUTTON

EMERGENCY SUPPORT

NissanConnect® Services provide various services to support dealing with emergencies of the subscribed vehicle and the driver.

For example, in case of an illness or serious injury, you can seek support by pushing the in-vehicle Emergency Call (SOS) button and connecting to the NissanConnect® Services Response Center. The NissanConnect® Services Response Center can specify the location of the vehicle via GNSS, and the information will be sent to the police or other agencies as needed.

For information about other NissanConnect® Services emergency support related services, contact the NissanConnect® Customer Support line at 1-855-426-6628 or refer to the NissanConnect® Services website www.nissanusa.com/connect (for U.S.) or www.nissan.ca/nissanconnect (English)/www.nissan.ca/nissanconnect/fr (French) (for Canada).



WARNING

- **Please note that the Automatic Collision Notification service and Emergency Call function cannot**

be used in the following conditions:

- Emergency functions and services will not be available without a paid subscription to NissanConnect® Services.
- The NissanConnect® Services network system is disabled.
- The vehicle moves outside the service area where the TCU (Telematics Control Unit) is connected to the system.
- The vehicle is outside the area where the cellular network service is receivable.
- The vehicle is in a location with poor signal reception such as tunnels, underground parking garages, behind buildings or in mountainous areas.
- The line is busy.
- The TCU (Telematics Control Unit) or other systems of your vehicle are not working properly.
- It may not be possible to make an emergency call depending on the severity of a

collision and/or emergency.

- Park the vehicle in a safe location and set the parking brake before operating the Emergency Call (SOS) button.
- Only use this service in case of an emergency. There may be a penalty for inappropriate use of the service.
- Radio waves could adversely affect electric medical equipment. Individuals who use a pacemaker should contact the device manufacturer regarding any possible effects before using the system.
- The TCU (Telematics Control Unit) antenna is installed inside the upper central part of the instrument panel. An occupant should not get any closer to the antenna than specified by the pacemaker manufacturer. The radio waves from the TCU antenna may adversely affect the operation of the pacemaker while using the NissanConnect® Services.

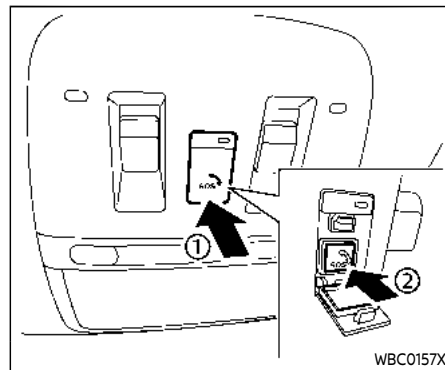

Making an emergency call

The Emergency Call (SOS) button is located near the map light.

1. Place the power switch in the ON position.
2. Push the cover ① to expose the Emergency Call (SOS) button ②.
3. Push the Emergency Call (SOS) button ② to make an emergency call.
4. When the line is connected, speak to the Response Specialist.

If you want to cancel the emergency call, push and hold the Emergency Call (SOS) button for a few seconds.

STORAGE

CUP HOLDERS



CAUTION

- Avoid abrupt starting and braking when the cup holder is being used to prevent spilling the drink. If the liquid is hot, it can scald you or your passenger.
- Use only soft cups in the cup holder. Hard objects can injure you in an accident.

NOTE:

- After the Emergency Call (SOS) button is pushed, it may take some time until the system initiates connection, depending on the technical environment and whether the TCU (Telematics Control Unit) is being used by other services.
- An indicator light on the Emergency Call (SOS) button shows the readiness of the emergency support system. If the indicator light is not illuminated, pushing the Emergency Call (SOS) button does not connect your vehicle to the Response Specialist.
The indicator light blinks while connected to the NissanConnect® Services Response Center.
- Even when the indicator light is illuminated, connection to the NissanConnect® Services Response Center may not be possible. If this occurs in an emergency situation, contact the authorities by other means.
- To avoid disconnecting the line, keep the EV system running during an emergency call, if it is safe to do so.

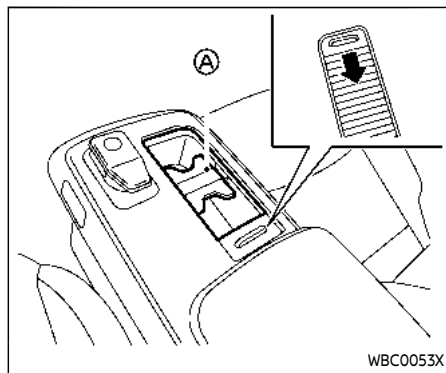

Front

Open the lid to use the cup holder.

The flaps **A** can be folded down when inserting a large container.

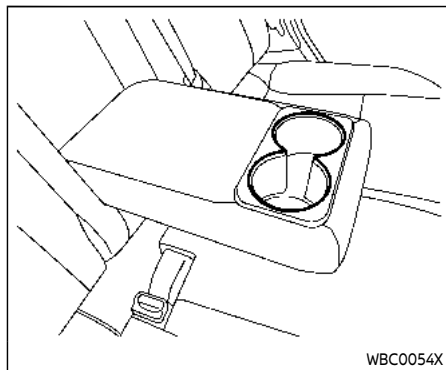

Rear seat (if so equipped)

The rear cup holders are located in the rear fold-down armrest.

SOFT BOTTLE HOLDERS

CAUTION

- Do not use bottle holder for any other objects that could be thrown about in the vehicle and possibly injure people during sudden braking or an accident.
- Do not use bottle holder for open liquid containers.

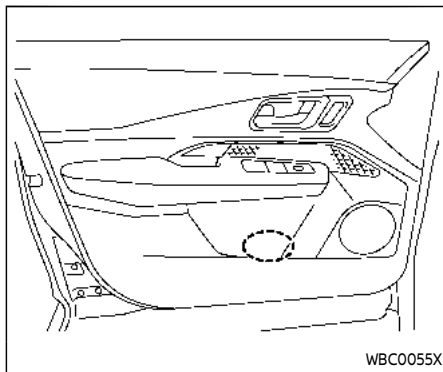

Door (front and rear)

ADJUSTABLE LUGGAGE FLOOR

You can use the luggage compartment in different ways using the adjustable luggage boards.

WARNING

Do not put objects heavier than 165 lbs (75 kg) on the load floor while in the upper position.

CAUTION

- Do not push the front edge of the luggage board forcibly. Doing so may cause the luggage board to be tilted, resulting in personal injury.
- Do not handle the luggage board forcibly as this may deform it.
- While in the upper position, do not recline the seatbacks.
- Do not place cargo higher than the seatbacks. In a sudden stop or collision, unsecured cargo could cause personal injury.

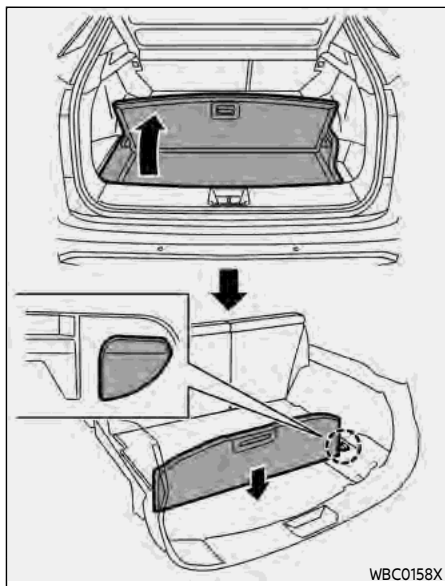

Vertical mode

1. Pull the rear board upward to 90°.
2. Push down the board until it stops.

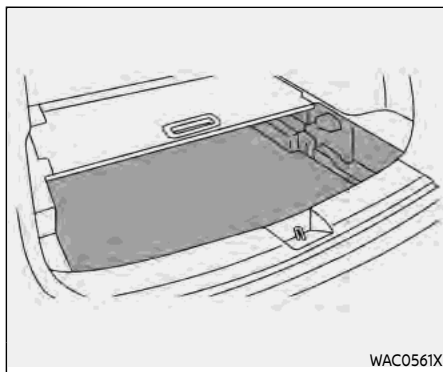

Luggage floor box (if so equipped)

To use the luggage floor box, pull off the rear board.

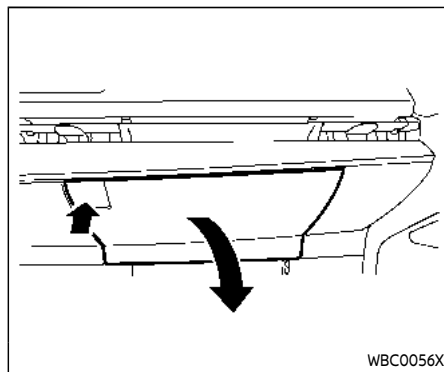

GLOVE BOX



WARNING

Keep glove box lid closed while driving to help prevent injury in an accident or a sudden stop.

To open the glove box, push the button.
To close, push the lid in until the lock latches.

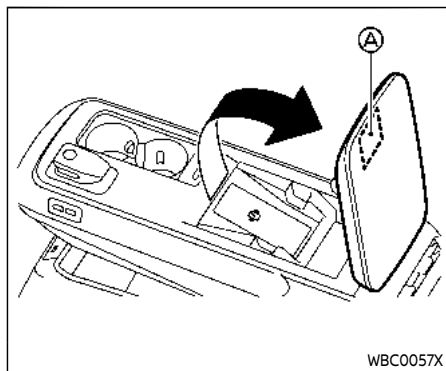

CONSOLE BOX

To open the console box lid, pull up the lid while pushing the button **A** at the inside of the lid.

To close, push the lid down.

The position of the console box can be adjusted to your desired position (if so equipped). See "Power sliding function" (P.2-85).

Power sliding function (if so equipped)



WARNING

Do not adjust the position of the console box while driving to help prevent injury in an accident or a sudden stop.

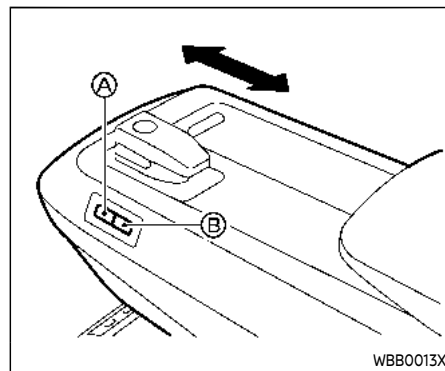

The position of the console box can be adjusted to your desired position.

To slide it forward, push and hold the switch **A**.

To slide it backward, push and hold the switch **B**.

FLEXIBLE CENTER STORAGE

WARNING

Keep flexible center storage closed while driving to help prevent injury in an accident or a sudden stop.

CAUTION

Do not store a total load of more than 3.3 lb (1.5 kg).

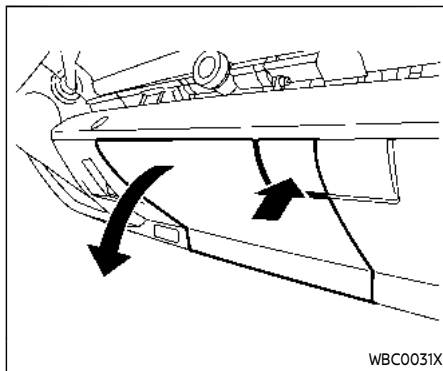

Manual operation type

To open the flexible center storage, push the button.

To close, push the lid in until the lock latches.

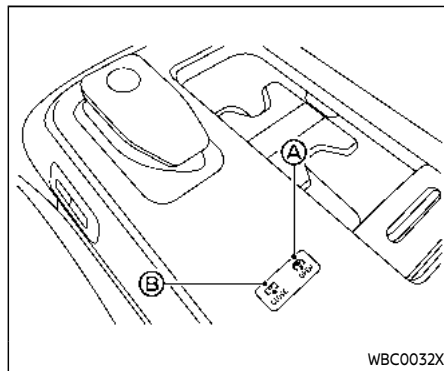

Power operation type

To open the flexible center storage, push and hold the OPEN side of the switch **A** located on the center console.

To close, push and hold the CLOSE side of the switch **B**.

NOTE:

- If the temperature inside the vehicle is very high, the power operation of the flexible center storage may stop working.
- If something is caught in the flexible center storage while it is closing, the lid may move toward the opening direction.

- If excessive load is applied to the top of the lid, the lid may move toward the closing direction.
- Flexible Center Storage should not be in the open position when the car is moving, the switch indicator will flash if the bin is open while the vehicle is moving.

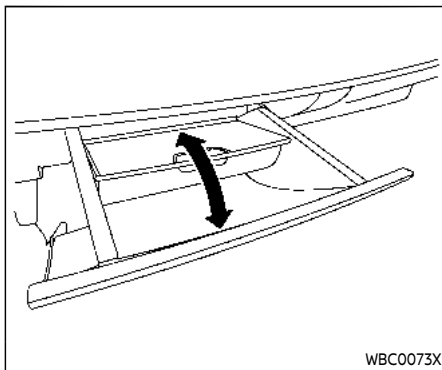

Table (if so equipped)



CAUTION

Do not apply a total load of more than 11 lb (5 kg) on the table.

The inside plate can be used as a table when the vehicle is parked.

To use the table, pull it out from the inside of the center storage.

When not in use, push it to the inside of the flexible center storage.

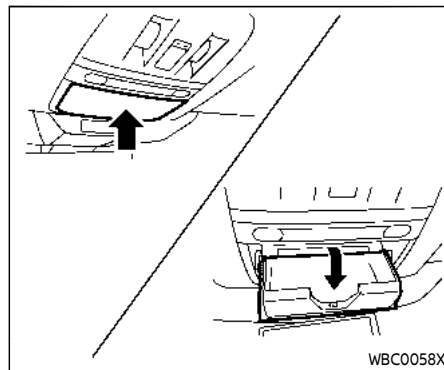

SUNGLASSES HOLDER



WARNING

Keep the sunglasses holder closed while driving to avoid obstructing the driver's view and to help prevent an accident.



CAUTION

- **Do not use for anything other than sunglasses.**

- **Do not leave sunglasses in the sunglasses holder while parking in direct sunlight. The heat may damage the sunglasses.**

To open the sunglasses holder, push and release. Only store one pair of sunglasses in the holder.

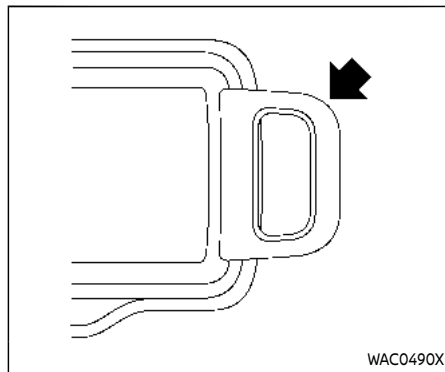

CARD HOLDER

Slide a card in the card holder.

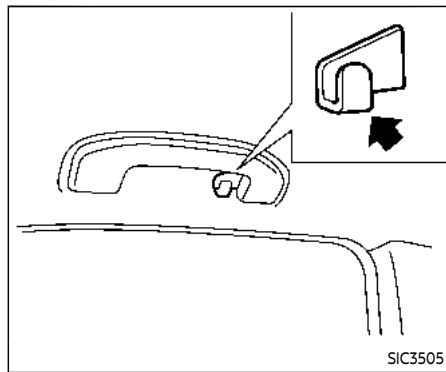

COAT HOOKS

The coat hook is located above the rear side window.



CAUTION

Do not apply a total load of more than 2 lb (1 kg) to the hook.

CARGO COVER (if so equipped)

WARNING

- Never put anything on the cargo cover, no matter how small. Any object on it could cause an injury in an accident or sudden stop.
- Do not leave the cargo cover in the vehicle when removed.
- Properly secure all cargo with ropes or straps to help prevent it from sliding or shifting. Do not place cargo higher than the seat-backs. In a sudden stop or collision, unsecured cargo could cause personal injury.
- Your child could be seriously injured or killed in a collision if the child restraint top tether strap is damaged.
 - If the cargo cover contacts the top tether strap when it is attached to the top tether anchor, remove the cargo cover from the vehicle or secure it on the cargo floor below its attachment location. If the cargo cover is not removed, it may damage the top tether strap during a collision.

sion.

- Do not allow cargo to contact the top tether strap when it is attached to the top tether anchor. Properly secure the cargo so it does not contact the top tether strap. Cargo that is not properly secured or that contacts the top tether strap may damage the top tether strap during a collision.

The cargo cover keeps the luggage compartment contents hidden from the outside.

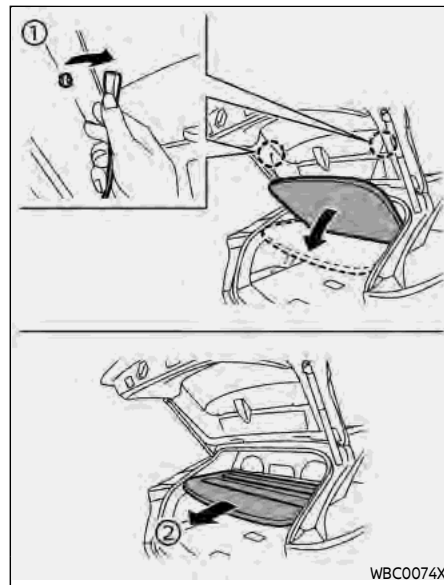

To remove the cargo cover:

1. Remove the straps from the liftgate.
2. Remove the cargo cover by slightly lifting up and then pulling it backward.

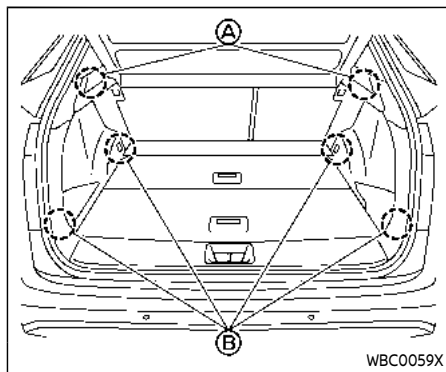

securing cargo.

LUGGAGE HOOKS

The hooks are located on the luggage compartment as shown.

WARNING

- Always make sure that the cargo is properly secured. Use the suitable ropes and hooks.
- Unsecured cargo can become dangerous in an accident or sudden stop.
- Do not apply a total load of more than 11 lbs. (5 kg) **A** or 22 lbs. (10 kg) **B** to a single hook when

ROOF RACK (if so equipped)

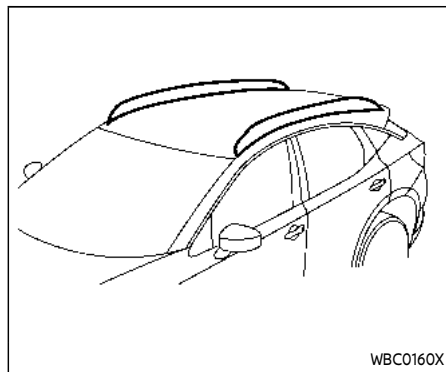

Do not apply any load directly to the roof side rails. Cross bars must be installed before applying load/cargo/luggage to the roof of the vehicle. Genuine NISSAN accessory cross bars are available through a NISSAN certified ARIYA dealer. It is recommended that you visit a NISSAN certified ARIYA dealer for additional information.

The service load capacity for the roof side rails is 163 lb (74 kg), however do not exceed the accessory cross bars load capacity.

Be careful that your vehicle does not exceed the Gross Vehicle Weight Rating (GVWR) or its Gross Axle Weight Rating

(GAWR front and rear). The GVWR and GAWR are located on the F.M.V.S.S. or C.V. M.S.S. certification label (located on the driver's door pillar). For additional information regarding GVWR and GAWR, refer to "Vehicle loading information" (P.10-9).



WARNING

- Always install the cross bars onto the roof side rails before loading cargo of any kind. Loading cargo directly onto the roof side rails or the vehicle's roof may cause vehicle damage.
- Drive extra carefully when the vehicle is loaded at or near the cargo carrying capacity, especially if the significant portion of that load is carried on the cross bars.
- Heavy loading of the cross bars has the potential to affect the vehicle stability and handling during sudden or unusual handling maneuvers.
- Roof rack cross bars should be evenly distributed.
- Do not exceed maximum roof rack cross bars load.

- Properly secure all cargo with ropes or straps to help prevent it from sliding or shifting. In a sudden stop or collision, unsecured cargo could cause personal injury.



CAUTION

Use care when placing or removing items from the roof rack. If you cannot comfortably lift the items onto the roof rack from the ground, use a ladder or a stool.

WINDOWS

POWER WINDOWS



WARNING

- Make sure that all passengers have their hands, etc. inside the vehicle while it is in motion and before closing the windows. Use the window lock switch to prevent unexpected use of the power windows.
- To help avoid risk of injury or death through unintended operation of the vehicle and or its systems, including entrapment in windows or inadvertent door lock activation, do not leave children, people who require the assistance of others or pets unattended in your vehicle. Additionally, the temperature inside a closed vehicle on a warm day can quickly become high enough to cause a significant risk of injury or death to people and pets.

The power windows operate when the power switch is in the ON position, or for a period of time after the power switch is placed in the OFF position. If the driver's or front passenger's door is opened dur-

ing this period of time, power to the windows is canceled.

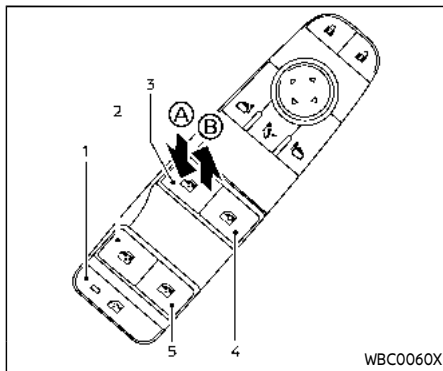

1. Window lock button
2. Rear left passenger side window
3. Driver side window
4. Front passenger side window
5. Rear right passenger side window

Main power window switch (driver's side)

To open or close the window, push down Ⓐ or pull up Ⓑ the switch and hold it. The main switch (driver side switches) will open or close all the windows.

Locking rear passenger's windows

When the window lock button is pushed (the indicator illuminates), the rear passenger's windows cannot be operated with the rear passenger's power window switch. The rear passenger's windows can only be operated with the main switch (driver side switches). To cancel the passenger's windows lock, push the window lock button again.

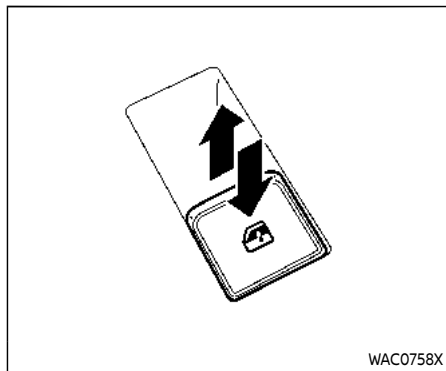

Passenger side power window switch

The passenger's switch can control its corresponding window. When the window lock button on the driver's switch is pushed, the rear passenger's switch cannot be operated.

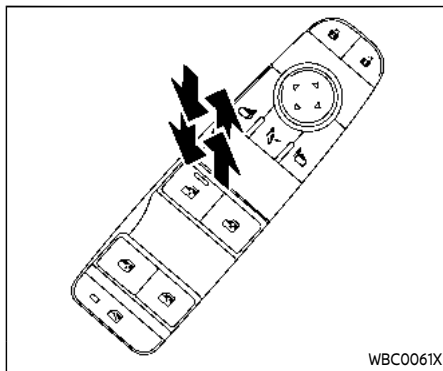

Automatic operation

The automatic function enables a window to fully open or close without holding the switch down or up.

To fully open the window, push the power window switch down to the second detent and release the switch. To fully close the window, pull the power window switch up to the second detent and release the switch. The switch does not have to be held during window operation.

To stop the window open/close operation during the automatic function, push down or pull up the switch in opposite directions.

Auto-reverse function



WARNING

There are some small distances immediately before the closed position which cannot be detected. Make sure that all passengers have their hands, etc., inside the vehicle before closing the window.

The auto-reverse function enables a window to automatically reverse when something is caught in the window as it is closing by the automatic function. When the control unit detects an obstacle, the window will be lowered immediately.

Depending on the environment or driving conditions, the auto-reverse function may activate if an impact or load similar to something being caught in the window occurs.

Window timer:

The window timer allows the window switch to be operated for a short time even if the power switch is placed in the OFF position. The window timer will be cancelled when the driver's or front passenger's side door is opened or the preset time has expired.

Operating windows with Intelligent Key

The windows can be opened by pushing the "UNLOCK" button on the Intelligent Key. This function will not operate while the window timer is activated or when the windows need to be initialized. For details about the Intelligent Key button usage, see "How to use remote keyless entry function" (P.3-15).

To open the windows, push the "UNLOCK"  button on the Intelligent Key for about 3 seconds after the door is unlocked.

To stop opening, release the "UNLOCK"  button.

If the window open operation is stopped on the way while pushing the "UNLOCK"  button, release and push the button again until the windows open completely.

When power window switch does not operate

If the power window automatic function does not operate properly, perform the following procedure to initialize the power window functions.

1. Close the door.
2. Place the power switch in the ON position.

3. Pull the power window switch and hold it to fully close the window.*1
4. Release the power window switch.
5. Pull the power window switch and hold it for approximately 5 seconds or more.*2
6. Push the power window switch down and hold it to fully open the window.
7. Release the power window switch.
8. Push the power window switch down and hold it for approximately 5 seconds or more.*2
9. Pull the power window switch and hold it to fully close the window.*1
10. Operate the window by the automatic function (window open and close) to confirm that the initialization is complete.

*1: If the window stops before reaching the fully closed position, release the switch, then pull and hold it again to fully close the window.

*2: After pulling or pushing the power window switch and holding it for approximately 5 seconds or more, the window will move again.

If the window cannot automatically be closed since the auto-reverse function activated due to a malfunction, perform the following procedure to cancel the

auto-reverse function.

1. Pull the power window switch up until the auto-reverse function is activated, then the window will reverse automatically.
2. Repeat the procedure twice.
3. Pull the power window switch and hold it to close the window to confirm that the cancellation is completed.



WARNING

When the auto-reverse function is canceled, the window will not automatically reverse even if the control unit detects an obstacle. Make sure that all passengers have their hands, etc. inside the vehicle before closing the windows.

If the power window functions do not operate properly after performing the procedure above, have your vehicle checked. It is recommended that you visit a NISSAN certified ARIYA dealer.

MOONROOF (if so equipped)

WARNING

- In an accident you could be thrown from the vehicle through an open moonroof. Always use seat belts and child restraints.
- Do not allow anyone to stand up or extend any portion of their body out of the moonroof opening while the vehicle is in motion or while the moonroof is closing.

CAUTION

- Remove water drops, snow, ice or sand from the moonroof before opening.
- Do not place any heavy object on the moonroof or surrounding area.

The moonroof only operates when the power switch is placed in the ON position. The moonroof is operational for a period of time, even if the power switch is placed in the OFF position. If the driver's door or the front passenger's door is opened during this period of time, the power to the moonroof is canceled.

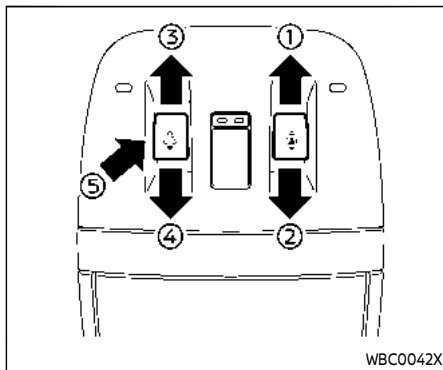

AUTOMATIC MOONROOF AND SUNSHADE

Sliding sunshade and moonroof

When the sunshade switch is pushed to the OPEN position ①, the sunshade will open. When the moonroof switch is pushed to the OPEN position ③, the moonroof opens to the comfort mode position. (If the sunshade is close, the sunshade will open half first. When the switch is pushed again, the moonroof will open fully.)

When the moonroof switch is pushed to the CLOSE position ④, the moonroof will automatically close. When the sunshade

switch is pushed to the CLOSE position ②, the sunshade will close.

To stop the sunshade or moonroof during the operation, push the moonroof switch to either of the OPEN ①, ③, CLOSE ②, ④ or UP ⑤ position.

Tilting moonroof

To tilt up the moonroof, push the moonroof switch to the up position ⑤.

To tilt down the moonroof, push the switch again or push to the CLOSE position ④.

Comfort mode

This is the position used when driving with the moonroof open. When driving with the moonroof fully open, wind noise may be very loud. Use the comfort mode position when driving.

Auto-reverse function

WARNING

There are some small distances just before the closed position which cannot be detected. Make sure that all passengers have their hands, etc. inside the vehicle before closing the moonroof and sunshade.

The auto-reverse function enables the moonroof and sunshade to automatically reverse when something is caught in the moonroof and sunshade as it is closing. When the control unit detects an obstacle, the moonroof and sunshade will open immediately.



Depending on the environment or driving conditions, the auto-reverse function may activate if an impact or load similar to something being caught in the moonroof and sunshade occurs.

If the auto-reverse function activates consecutively or the battery is discharged, the moonroof and sunshade may not close properly. In this case, push and hold the switch to the CLOSE position ④ to close the moonroof.

Operating moonroof with Intelligent Key

The moonroof can be opened by pushing the UNLOCK  button on the Intelligent Key. This function will not operate while the moonroof timer is activated or when the moonroof needs to be initialized. For details about the Intelligent Key button usage, see "How to use remote keyless entry function" (P.3-15).

To open the moonroof, push and hold the UNLOCK  button on the Intelligent Key. The operation will stop after about 7

seconds. You can continue the operation by pushing and holding the UNLOCK  button again. To stop opening, release the UNLOCK  button.

If the moonroof does not operate

If the moonroof and sunshade do not operate properly, perform the following procedure to initialize the operation system.

1. If the moonroof and sunshade are open, close them fully by repeatedly pushing the moonroof switch to the CLOSE ② and ④ position.
2. Push and hold the moonroof switch to the CLOSE ④ position for 10 seconds.
3. After the moonroof and sunshade move slightly to the closed position and then move back a little, release the moonroof switch.
4. Push and hold the moonroof switch to the CLOSE ④ position, and the glass and shade will move.
5. Release the moonroof switch. Then the moonroof and sunshade will fully open and then fully close.
6. Check if the moonroof switch operates normally.



WARNING

The driver is always responsible for operating the moonroof properly, including the operation by all passengers. Failure to follow the warnings and instructions for proper use of the moonroof could result in serious injury or death.

- **Do not allow children to operate the moonroof. Improper operation by children may cause an accident. If children or others get caught in the moonroof, it could cause serious injury.**
- **To help avoid risk of injury or death through unintended operation of the moonroof, place the power switch in the OFF position when leaving the vehicle, and do not leave children and the Intelligent Key inside the vehicle.**
- **Do not activate the auto-reverse function intentionally. If hands or face, etc. get caught in the moonroof, it could cause serious injury.**



CAUTION

- Do not place objects (such as newspapers, handkerchiefs, etc.) on the sunshade when it is extending or retracting causing improper operation or damage to the sunshade.
- Do not push the sunshade arm with your hands, etc., as this may deform it. Improper operation or damage to the sunshade may result.
- Do not put any object into the sunshade inlet port as this may result in improper operation or damage the sunshade.
- Do not hang any object on the arm rail as this may result in improper operation or damage the sunshade.
- Do not forcefully pull the sunshade. Doing so may elongate the sunshade. Improper operation or damage to the sunshade may result.

If the moonroof does not operate properly after performing the procedure above, have your vehicle checked. It is

recommended that you visit a NISSAN certified ARIYA dealer.

INTERIOR LIGHTS



CAUTION

- Do not leave the light switch on when the EV system is not running for extended periods of time to prevent the 12-volt battery from being discharged.
- Turn off the lights when you leave the vehicle.

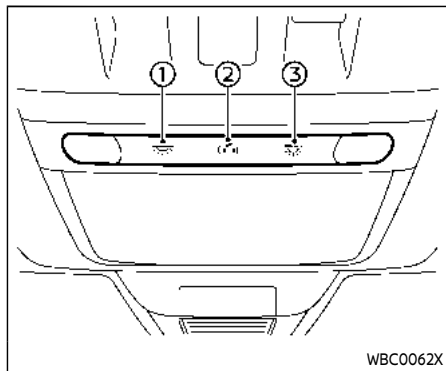

INTERIOR LIGHT SWITCH

- ① The interior lights can be turned ON regardless of door position. The lights will go off after a period of time unless the power switch is placed in the ON position when any door is opened.
- ② The interior lights can be set to operate when the doors are opened. To turn off the interior lights when a door is open, touch the switch, the interior lights will not illuminate, regardless of door position. The lights will go off when the power switch is placed in the ON position, or the driver's door is closed and locked.
- ③ The brightness of the map lights can be adjusted in 4 levels by touching this switch.

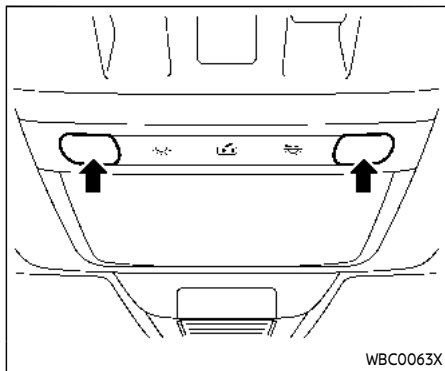

MAP LIGHTS

Touch the light to turn the map lights on. To turn the light off, touch the light again

The lights will also turn off after a period of time when the lights remain illuminated to prevent the 12-volt battery from becoming discharged.

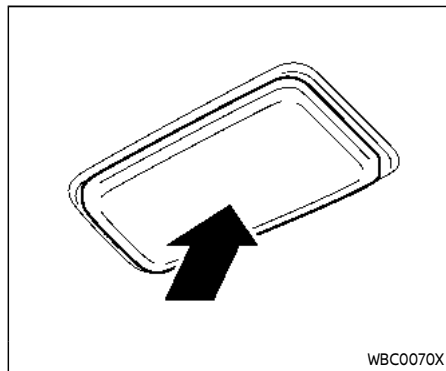

REAR PERSONAL LIGHTS

To turn the rear personal light on, touch the light. Touch the light again to dim the light. To turn off the light, touch the light once again.

The lights will also turn off after a period of time when the lights remain illuminated to prevent the 12-volt battery from becoming discharged.

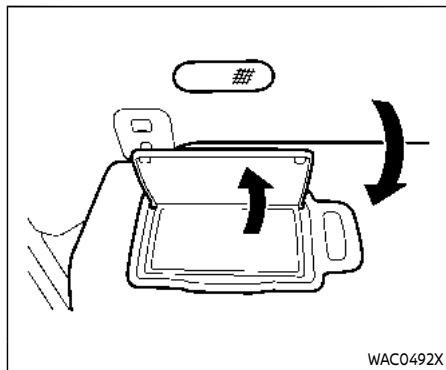

CARGO LIGHT

The cargo light illuminates when the liftgate is opened.

The light will turn off after a period of time when the light remains illuminated to prevent the battery from becoming discharged.

VANITY MIRROR LIGHT

The light over the vanity mirror will turn on when the cover on the vanity mirror is opened.

When the cover is closed, the light will turn off.

The lights will also turn off after a period of time when the lights remain illuminated to prevent the 12-volt battery from becoming discharged.

HomeLink® UNIVERSAL TRANSCEIVER (if so equipped)

The HomeLink® Universal Transceiver provides a convenient way to consolidate the functions of up to three individual hand-held transmitters into one built-in device.

HomeLink® Universal Transceiver:

- Will operate most Radio Frequency (RF) devices such as garage doors, gates, home and office lighting, entry door locks and security systems.
- Is powered by your vehicle's battery. No separate batteries are required. If the vehicle's battery is discharged or is disconnected, HomeLink® will retain all programming.

When the HomeLink® Universal Transceiver is programmed, retain the original transmitter for future programming procedures (Example: new vehicle purchases). Upon sale of the vehicle, the programmed HomeLink® Universal Transceiver buttons should be erased for security purposes. For additional information, refer to "Programming HomeLink®" (P.2-100).



WARNING

- **Your vehicle's EV system should be turned off while programming the HomeLink® Universal Trans-**

ceiver. For additional information, see "Push-button power switch" (P.5-13).

- Do not use the HomeLink® Universal Transceiver with any garage door opener that lacks safety stop and reverse features as required by federal safety standards. (These standards became effective for opener models manufactured after April 1, 1982.) A garage door opener which cannot detect an object in the path of a closing garage door and then automatically stop and reverse, does not meet current federal safety standards. Using a garage door opener without these features increases the risk of serious injury or death.
- During the programming procedure your garage door or security gate will open and close (if the transmitter is within range). Make sure that people or objects are clear of the garage door, gate, etc. that you are programming.

PROGRAMMING HomeLink®

The following steps show generic instructions how to program a HomeLink® button. If you have any questions or are having difficulty programming your HomeLink® buttons, refer to the HomeLink® web site at: www.homelink.com/nissan or call 1-800-355-3515.

NOTE:

It is also recommended that a new battery be placed in the hand-held transmitter of the device being programmed to HomeLink® for quicker programming and accurate transmission of the radio-frequency.

1. Position the end of your hand-held transmitter 1-3 in (26-76 mm) away from the HomeLink® surface, keeping the HomeLink® indicator light ① in view.

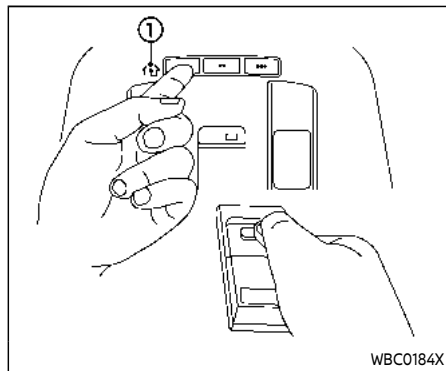

2. Using both hands, simultaneously press and hold the desired HomeLink® button and handheld transmitter button. DO NOT release until the HomeLink® indicator light ① flashes slowly and then rapidly. When the indicator light flashes rapidly, both buttons may be released. (The rapid flashing indicates successful programming.)

NOTE:

Some devices to be programmed may require you to replace Step 2 with the cycling procedure noted in the "Programming HomeLink® for Canadian customers and gate openers" (P.2-101).

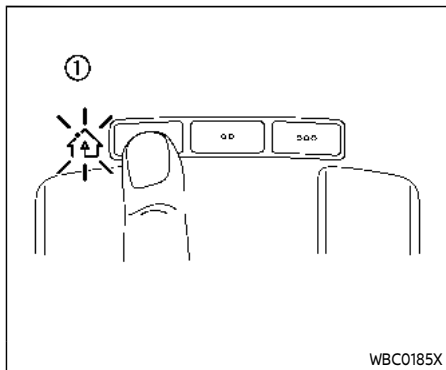

3. Press and hold the programmed HomeLink® button and observe the indicator light.
 - If the indicator light ① is solid/continuous, programming is complete and your device should activate when the HomeLink® button is pressed and released.
 - If the indicator light ① blinks rapidly for two seconds and then turns to a solid/continuous light, continue with Steps 4-6 for a rolling code device. A second person may make the following steps easier. Use a ladder or other device. Do not stand on your vehicle to perform the next steps.

4. At the receiver located on the garage door opener motor in the garage, locate the “learn” or “smart” button (the name and color of the button may vary by manufacturer but it is usually located near where the hanging antenna wire is attached to the unit). If there is difficulty locating the button, reference the garage door opener’s manual.

5. Press and release the “learn” or “smart” button.

NOTE:

Once the button is pressed, you have approximately 30 seconds to initiate the next step.

6. Return to the vehicle and firmly press and hold the programmed HomeLink® button for two seconds and release. Repeat the “press/hold/release” sequence up to 3 times to complete the programming process. HomeLink® should now activate your rolling code equipped device.
7. If you have any questions or are having difficulty programming your HomeLink® buttons, refer to the HomeLink® web site at: www.homelink.com/nissan or call 1-800-355-3515.

PROGRAMMING HomeLink® FOR CANADIAN CUSTOMERS AND GATE OPENERS

Canadian radio-frequency laws require transmitter signals to “time-out” (or quit) after several seconds of transmission – which may not be long enough for HomeLink® to pick up the signal during programming. Similar to this Canadian law, some U.S. gate operators are designed to “time-out” in the same manner.

If you live in Canada or you are having difficulties programming a gate operator or garage door opener by using the “Programming HomeLink®” procedures, replace “Programming HomeLink®” Step 2 with the following:

NOTE:

When programming a garage door opener, etc., unplug the device during the “cycling” process to prevent possible damage to the garage door opener components.

Step 2: Using both hands, simultaneously press and hold the desired HomeLink® button and the hand-held transmitter button. During programming, your hand-held transmitter may automatically stop transmitting. Continue to press and hold the desired HomeLink® button while you press and re-press (“cycle”) your hand-

held transmitter every two seconds until the frequency signal has been learned. The HomeLink® indicator light will flash slowly and then rapidly after several seconds upon successful programming. **DO NOT** release until the HomeLink® indicator light flashes slowly and then rapidly. When the indicator light flashes rapidly, both buttons may be released. The rapid flashing indicates successful programming.

Proceed with "Programming HomeLink®" step 3 to complete.

Remember to plug the device back in when programming is completed.

OPERATING THE HomeLink® UNIVERSAL TRANSCIEVER

The HomeLink® Universal Transceiver, after it is programmed, can be used to activate the programmed device. To operate, simply press and release the appropriate programmed HomeLink® Universal Transceiver button. The amber indicator light will illuminate while the signal is being transmitted.

For convenience, the hand-held transmitter of the device may also be used at any time.

PROGRAMMING TROUBLESHOOTING

If the HomeLink® does not quickly learn the hand-held transmitter information:

- replace the hand-held transmitter batteries with new batteries.
- position the hand-held transmitter with its battery area facing away from the HomeLink® surface.
- press and hold both the HomeLink® and hand-held transmitter buttons without interruption.
- position the hand-held transmitter 1-3 in (26-76 mm) away from the HomeLink® surface. Hold the transmitter in that position for up to 15 seconds. If HomeLink® is not programmed within that time, try holding the transmitter in another position - keeping the indicator light in view at all times.

If you have any questions or are having difficulty programming your HomeLink® buttons, refer to the HomeLink® web site at: www.homelink.com/nissan or 1-800-355-3515.

CLEARING THE PROGRAMMED INFORMATION

The following procedure clears the programmed information from both buttons. Individual buttons cannot be cleared. However, individual buttons can be reprogrammed, see "Reprogramming a single HomeLink® button" (P.2-102).

To clear all programming

1. Press and hold the two outer HomeLink® buttons until the indicator light begins to flash in approximately 10 seconds. Do not hold for longer than 20 seconds.
2. Release both buttons.

HomeLink® is now in the programming mode and can be programmed at any time beginning with "Programming HomeLink®" - Step 1.

REPROGRAMMING A SINGLE HomeLink® BUTTON

To reprogram a HomeLink® Universal Transceiver button, complete the following.

1. Press and hold the desired HomeLink® button. **Do not** release the button.
2. The indicator light will begin to flash after 20 seconds. Without releasing the HomeLink® button, proceed with

"Programming HomeLink®" - Step 1.

For questions or comments, contact HomeLink® at: www.homelink.com/nissan or 1-800-355-3515.

The HomeLink® Universal Transceiver button has now been reprogrammed. The new device can be activated by pushing the HomeLink® button that was just programmed. This procedure will not affect any other programmed HomeLink® buttons.

IF YOUR VEHICLE IS STOLEN

If your vehicle is stolen, you should change the codes of any non-rolling code device that has been programmed into HomeLink®. Consult the Owner's Manual of each device or call the manufacturer or dealer of those devices for additional information.

When your vehicle is recovered, you will need to reprogram the HomeLink® Universal Transceiver with your new transmitter information.

FCC Notice:

For USA:

This device complies with Part 15 of the FCC Rules. Operation is subject to the following two conditions: (1) This device may not cause harmful interference, and (2) this device must accept any

interference received, including interference that may cause undesired operation.

NOTE:

Changes or modifications not expressly approved by the party responsible for compliance could void the user's authority to operate the equipment.

For Canada:

This device contains licence-exempt transmitter(s)/receiver(s) that comply with Innovation, Science and Economic Development Canada's licence-exempt RSS(s). Operation is subject to the following two conditions: (1) This device may not cause interference. (2) This device must accept any interference, including interference that may cause undesired operation of the device.

MEMO

3 Pre-driving checks and adjustments

Keys	3-2	Operating power liftgate (if so equipped)	3-22
Intelligent Key	3-2	Motion-activated liftgate (if so equipped)	3-24
Doors	3-4	Garage mode system (if so equipped)	3-25
Locking with key	3-4	Auto closure (if so equipped)	3-26
Locking with inside lock knob	3-4	liftgate release lever	3-26
Locking with power door lock switch	3-5	Charge port lid	3-27
Automatic door locks	3-5	Opening charge port lid	3-27
Child safety rear door lock	3-6	Charge port cap	3-27
Intelligent Key system	3-6	Charge port light	3-28
Intelligent Key operating range	3-8	Tilt/telescopic steering	3-29
Door locks/unlocks precaution	3-8	Manual steering wheel adjustment	3-29
Intelligent Key operation	3-9	Electric steering wheel adjustment	3-29
Approach unlock function	3-11	Sun visors	3-30
Walk away lock function	3-11	Mirrors	3-31
12-volt battery saver system	3-11	Inside mirror	3-31
Warning lights and audible reminders	3-12	Outside mirrors	3-38
Troubleshooting guide	3-13	Vanity mirror	3-41
How to use remote keyless entry function	3-15	Memory seat (if so equipped)	3-41
Hood	3-20	Memory storage function	3-41
Liftgate	3-21	Entry/Exit function	3-42
Operating manual liftgate (if so equipped)	3-21	System operation	3-43

KEYS

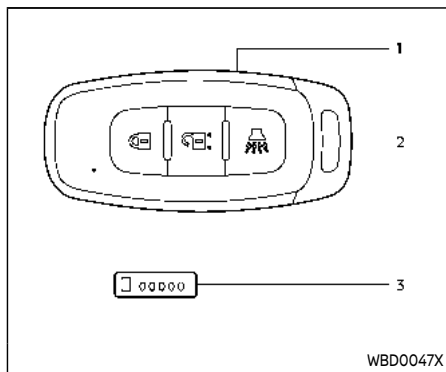

Type A (if so equipped)

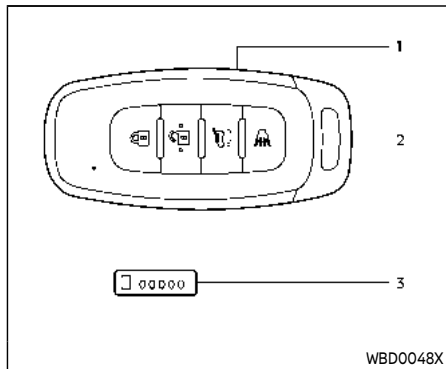

Type B (if so equipped)

1. Intelligent Key (2)
2. Mechanical key (inside Intelligent Key) (2)
3. Key number plate

INTELLIGENT KEY

Your vehicle can only be driven with the Intelligent Keys which are registered to your vehicle's Intelligent Key system components and NISSAN Anti-Theft System (NATS) components. As many as 4 Intelligent Keys can be registered and used with one vehicle. The new keys must be registered by a NISSAN certified ARIYA dealer prior to use with the Intelligent Key system and NISSAN Anti-Theft System (NATS) of your vehicle. Since the registration process requires erasing all memory in the Intelligent Key components when registering new keys, be sure to take all Intelligent Keys that you have to the NISSAN certified ARIYA dealer.

A key number plate is supplied with your keys. Record the key number and keep it in a safe place (such as your wallet), not in the vehicle. If you lose your keys, it is recommended you visit a NISSAN certified ARIYA dealer for duplicates by using the key number. NISSAN does not record any key numbers so it is very important to keep track of your key number plate.

A key number is only necessary when you have lost all keys and do not have one to duplicate from. If you still have a key, it

can be duplicated without knowing the key number.



CAUTION

- **Be sure to carry the Intelligent Key with you when driving. The Intelligent Key is a precision device with a built-in transmitter. To avoid damaging it, please note the following.**
 - The Intelligent Key is water resistant; however, wetting may damage the Intelligent Key. If the Intelligent Key gets wet, immediately wipe until it is completely dry.
 - Do not bend, drop or strike it against another object.
 - If the outside temperature is below 14°F (-10°C) degrees, the battery of the Intelligent Key may not function properly.
 - Do not place the Intelligent Key for an extended period in a place where temperatures exceed 140°F (60°C).
 - Do not change or modify the Intelligent Key.

- Do not use a magnet key holder.
- Do not place the Intelligent Key near an electric appliance such as a television set, personal computer or cellular phone.
- Do not allow the Intelligent Key to come into contact with water or salt water, and do not wash it in a washing machine. This could affect the system function.

If an Intelligent Key is lost or stolen, NISSAN recommends erasing the ID code of that Intelligent Key. This will prevent the Intelligent Key from unauthorized use to unlock the vehicle. For information regarding the erasing procedure, it is recommended you visit a NISSAN certified ARIYA dealer.

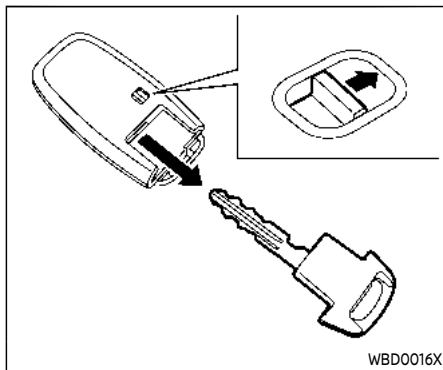

Mechanical key

To remove the mechanical key, release the lock knob at the back of the Intelligent Key.

To install the mechanical key, firmly insert it into the Intelligent Key until the lock knob returns to the lock position.

Use the mechanical key to lock or unlock the driver's door. (See "Doors" (P.3-4).)



CAUTION

Always carry the mechanical key installed in the Intelligent Key.

DOORS

WARNING

- Always have the doors locked while driving. Along with the use of seat belts, this provides greater safety in the event of an accident by helping to prevent persons from being thrown from the vehicle. This also helps keep children and others from unintentionally opening the doors, and will help keep out intruders.
- Before opening any door, always look for and avoid oncoming traffic.
- To help avoid risk of injury or death through unintended operation of the vehicle and/or its systems, including entrapment in windows or inadvertent door lock activation, do not leave children, people who require the assistance of others or pets unattended in your vehicle. Additionally, the temperature inside a closed vehicle on a warm day can quickly become high enough to cause a significant risk of injury or death to people and pets.

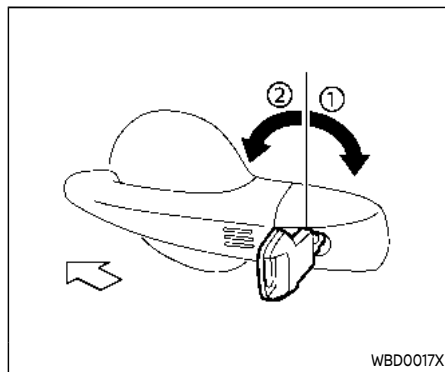

LOCKING WITH KEY

To lock the driver's door, turn the driver's door key cylinder to the rear of the vehicle ①.

To unlock the driver's door, turn the driver's door key cylinder to the front of the vehicle ②.

To lock or unlock the other doors and the liftgate, use the Intelligent Key function. (See "Intelligent Key system" (P.3-6).)

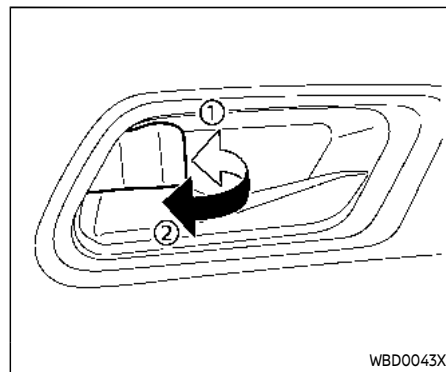

LOCKING WITH INSIDE LOCK KNOB

To lock the door without the key, move the inside lock knob to the lock position ① then close the door.

To unlock, move the inside lock knob to the unlock position ②.

To unlock and open the front door without using the lock knob, pull once on the door handle to unlock it, and again to open it.

When locking the door without a key, be sure not to leave the key inside the vehicle.

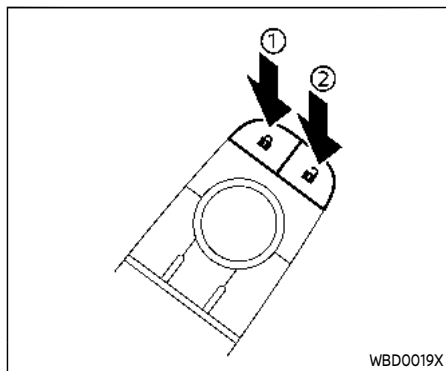

Driver's armrest

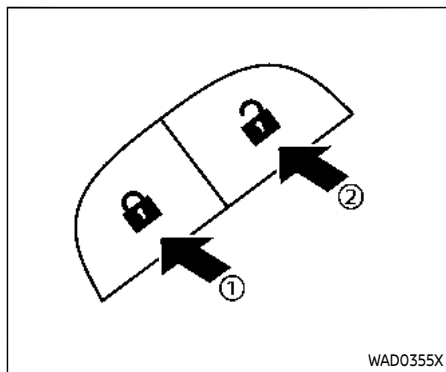

Front passenger's armrest

LOCKING WITH POWER DOOR LOCK SWITCH

Operating the power door lock switch (located on the driver's and front passenger's doors) will lock or unlock all the doors.

To lock the doors, push the power door lock switch to the lock position ① with the driver's door open, then close the door.

When locking the door this way, be sure not to leave the key inside the vehicle.

To unlock the doors, push the power door lock switch to the unlock position ②.

Lockout protection

Lockout protection function helps to prevent the keys from being accidentally locked inside the vehicle.

When the power door lock switch is moved to the lock position with any door open, all doors will unlock automatically and a chime will sound after the door is closed.

AUTOMATIC DOOR LOCKS

- All doors lock automatically when the vehicle speed reaches 15 MPH (24 km/h).
- All doors unlock automatically when the power switch is placed in the OFF position or when the shift position is

placed in the P (Park) position, if selected.

NOTE:

The Automatic door unlock feature can be changed using the "Vehicle Settings" menu on the vehicle information display. (See "Vehicle Settings" (P.2-28).)

INTELLIGENT KEY SYSTEM

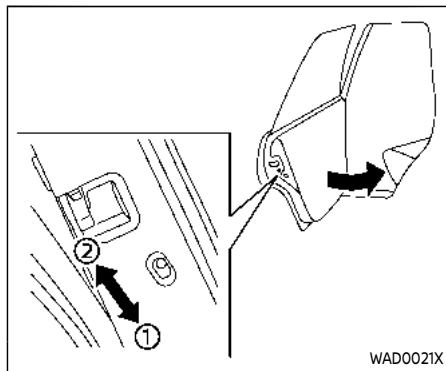

CHILD SAFETY REAR DOOR LOCK

Child safety rear door locks help prevent the rear doors from being opened accidentally, especially when small children are in the vehicle.

When the levers are in the lock position ①, the rear doors can be opened only from the outside.

To disengage, move the levers to the unlock position ②.



WARNING

- Radio waves could adversely affect electric medical equipment. Those who use a pacemaker should contact the electric medical equipment manufacturer for the possible influences before use.
- The Intelligent Key transmits radio waves when the buttons are pushed. The radio waves may affect aircraft navigation and communication systems. Do not operate the Intelligent Key while on an airplane. Make sure the buttons are not operated unintentionally when the unit is stored during a flight.

The Intelligent Key system can operate all the door locks using the remote controller function, touching lock or capacitive unlock sensor or pushing the request switch on the vehicle without taking the key out from a pocket or purse. The operating environment and/or conditions may affect the Intelligent Key system operation.

Be sure to read the following before using the Intelligent Key system.



CAUTION

- Be sure to carry the Intelligent Key with you when operating the vehicle.
- Never leave the Intelligent Key in the vehicle when you leave the vehicle.

The Intelligent Key is always communicating with the vehicle as it receives radio waves. The Intelligent Key system transmits weak radio waves. Environmental conditions may interfere with the operation of the Intelligent Key system under the following operating conditions.

- When operating near a location where strong radio waves are transmitted, such as a TV tower, power station and broadcasting station.
- When in possession of wireless equipment, such as a cellular phone, transceiver, and CB radio.
- When the Intelligent Key is in contact with or covered by metallic materials.
- When any type of radio wave remote control is used nearby.
- When the Intelligent Key is placed near an electric appliance such as a personal computer.

- When the vehicle is parked near a parking meter.

In such cases, correct the operating conditions before using the Intelligent Key function or use the mechanical key.

Although the life of the battery varies depending on the operating conditions, the battery's life is approximately 2 years. If the battery is discharged, replace it with a new one.

When the Intelligent Key battery is low, an indicator illuminates in the vehicle information display. (See "4. Key Battery Low warning" (P.2-34).)

Since the Intelligent Key is continuously receiving radio waves, if the key is left near equipment which transmits strong radio waves, such as signals from a TV and personal computer, the battery life may become shorter.

For information regarding replacement of a battery, see "Intelligent Key battery replacement" (P.8-13).

As many as 4 Intelligent Keys can be registered and used with one vehicle. For information about the purchase and use of additional Intelligent Keys, it is recommended that you contact a NISSAN certified ARIYA dealer.



CAUTION

- **Do not allow the Intelligent Key, which contains electrical components, to come into contact with water or salt water. This could affect the system function.**
- **Do not drop the Intelligent Key.**
- **Do not strike the Intelligent Key sharply against another object.**
- **Do not change or modify the Intelligent Key.**
- **Wetting may damage the Intelligent Key. If the Intelligent Key gets wet, immediately wipe until it is completely dry.**
- **If the outside temperature is below 14°F (-10°C) degrees, the battery of the Intelligent Key may not function properly.**
- **Do not place the Intelligent Key for an extended period in an area where temperatures exceed 140°F (60°C).**
- **Do not attach the Intelligent Key with a key holder that contains a magnet.**
- **Do not place the Intelligent Key near equipment that produces a**

magnetic field, such as a TV, audio equipment, personal computers, cellular phone or wireless charger.

If an Intelligent Key is lost or stolen, NISSAN recommends erasing the ID code of that Intelligent Key from the vehicle. This may prevent the unauthorized use of the Intelligent Key to operate the vehicle. For information regarding the erasing procedure, it is recommended that you contact a NISSAN certified ARIYA dealer.

The Intelligent Key function can be disabled. For information about disabling the Intelligent Key function, it is recommended that you contact a NISSAN certified ARIYA dealer.

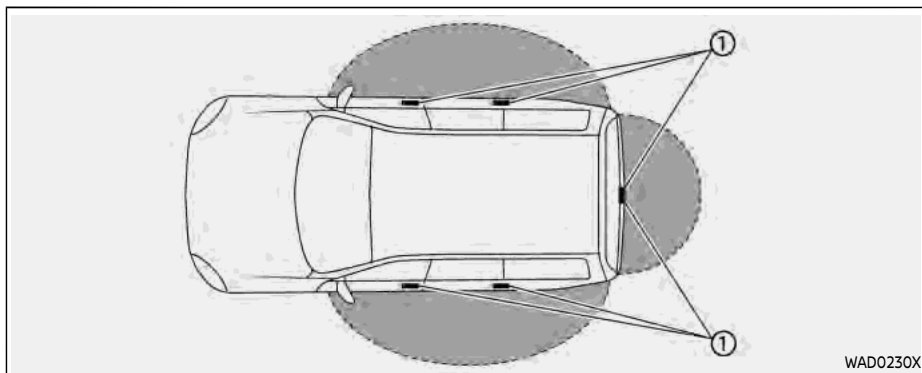

INTELLIGENT KEY OPERATING RANGE

The Intelligent Key functions can only be used when the Intelligent Key is within the specified operating range from the lock or capacitive unlock sensors or the liftgate request switch ①.

When the Intelligent Key battery is discharged or strong radio waves are present near the operating location, the Intelligent Key system's operating range becomes narrower, and the Intelligent Key may not function properly.

The operating range is within 31.50 in (80 cm) from each sensor or request switch ①.

3-8 Pre-driving checks and adjustments

If the Intelligent Key is too close to the door glass, handle or rear bumper, the sensors or the request switch may not function.

When the Intelligent Key is within the operating range, it is possible for anyone who does not carry the Intelligent Key to use the lock or capacitive unlock sensors or request switch to lock or unlock the doors including the liftgate.

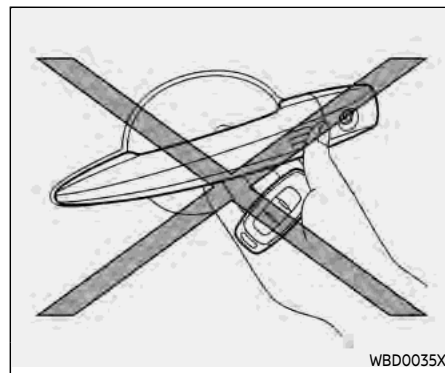

DOOR LOCKS/UNLOCKS PRECAUTION

- Do not use the lock or capacitive unlock sensors or the liftgate request switch with the Intelligent Key held in your hand as illustrated. The close distance to the door handle will cause the Intelligent Key system to have difficulty recognizing that the Intelligent Key is outside the vehicle.
- After locking with the lock sensors or the request switch, verify the doors are securely locked by testing them.
- To prevent the Intelligent Key from being left inside the vehicle, make sure you carry the key with you and then

lock the doors.

- Do not pull the door handle before unlocking it by the capacitive unlock sensor or the request switch.

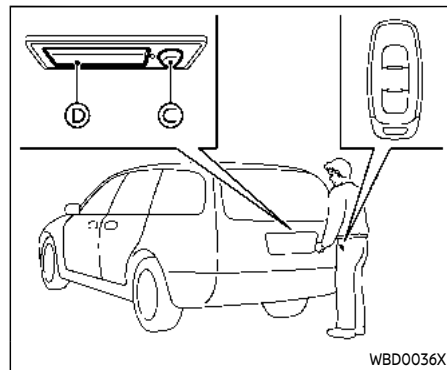
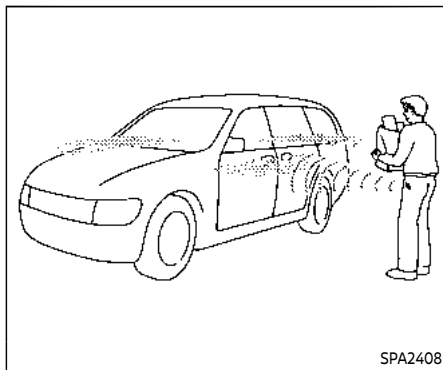

Example

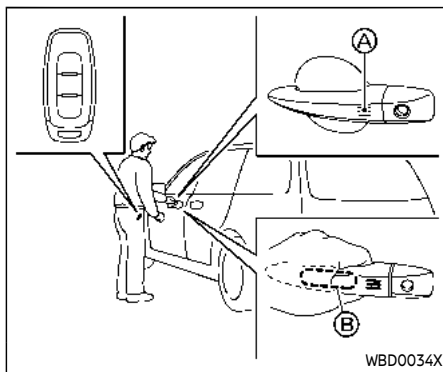

Example

INTELLIGENT KEY OPERATION

You can lock or unlock the doors without taking the key out from your pocket or bag.

When you carry the Intelligent Key with you, you can lock all doors by using the lock sensor **A** (located on the door handles) or liftgate request switch **C** within the range of operation.

You can unlock all the door and liftgate by touching the capacitive unlock sensor **B** (located inside of the door handles) within the range of operation.

When you lock or unlock the doors, the hazard indicator will flash and the outside

chime will sound as a confirmation. For details, see "Setting hazard indicator and horn mode" (P.3-18).

NOTE:



- **The lock or capacitive unlock sensors and the liftgate request switch can be deactivated in the Vehicle Settings of the vehicle information display. (See "Vehicle Settings" (P.2-28).)**
- **The lock or capacitive unlock sensors are operational only when the Intelligent Key has been detected by the Intelligent Key system.**

Welcome light function

When you unlock the doors or the liftgate, the emblem light, parking lights and the tail lights will illuminate for a period of time. The welcome light function can be disabled. For information about disabling the welcome light function, see "Vehicle Settings" (P.2-28).

Locking doors

1. Push the park button to engage the P (Park) position. Place the power switch in the OFF position and make sure you carry the Intelligent Key with you.
2. Close all doors.

3. Touch the lock sensor  or push the liftgate request switch  while carrying the Intelligent Key with you.
4. All doors and the liftgate will lock.
5. The hazard indicator lights flash twice and the outside buzzer sounds twice.

NOTE:

- **Doors lock with the lock sensor or liftgate request switch while the power switch is in the ON position. The EV system will stop automatically.**
- **Doors do not lock by driver's door lock sensor while the driver's door is open. However, doors lock with the mechanical key even if any door is open.**
- **Doors do not lock with the lock sensor or the liftgate request switch with the Intelligent Key inside the vehicle and a beep sounds to warn you. However, when an Intelligent Key is inside the vehicle, doors can be locked with another Intelligent Key.**





CAUTION

- **After locking the doors using the lock sensor or the liftgate request switch, make sure that the doors**

have been securely locked by operating the door handles or the liftgate opener switch.

- **When locking the doors using the lock sensor or the liftgate request switch, make sure to have the Intelligent Key in your possession before operating the lock sensor or the liftgate request switch to prevent the Intelligent Key from being left in the vehicle.**

Unlocking doors

1. Carry the Intelligent Key with you.
2. Wrap the door handle (capacitive unlock sensor)  or push the liftgate request switch .
3. The hazard indicator flashes once and outside chime sounds once.
 - When the driver's door handle capacitive unlock sensor or the liftgate request switch is used:
The corresponding door or the liftgate will unlock.
 - When the other door handle capacitive unlock sensor is used:
All doors and the liftgate will unlock.
4. Wrap the door handle (capacitive unlock sensor) or push the liftgate request switch again within 1 minute.

- The hazard indicator flashes once and outside chime sounds once again. All the doors and the liftgate will unlock.



CAUTION

If a door handle is pulled while unlocking the doors, that door may not be unlocked. Returning the door handle to its original position will unlock the door. If the door does not unlock, after returning the door handle, touch the capacitive unlock sensor or push the request switch to unlock the door.

All doors will be locked automatically unless one of the following operations is performed within 1 minute after touching the capacitive unlock sensor or pushing the request switch while the doors are locked.

- Opening any doors.
- Pushing the power switch.

If during the preset time period, the "UNLOCK"  button on the Intelligent Key is pushed, all doors will be locked automatically after another 1 minute.

NOTE:

The unlocking operation can be changed in "Selective Unlock" under the Vehicle Settings of the vehicle information display. For additional information, see "Vehicle Settings" (P.2-28).

Opening liftgate

- Carry the Intelligent Key.
- Push the liftgate opener switch .
- The liftgate will unlock and then open.

APPROACH UNLOCK FUNCTION

When you approach the vehicle with the Intelligent Key, the vehicle will be unlocked automatically by the approach unlock function. This function is disabled by the default setting. You can enable this function by the vehicle information display. For additional information, see "Vehicle Settings" (P.2-28).

WALK AWAY LOCK FUNCTION

When you walk away from the vehicle with the Intelligent Key, the vehicle will be locked automatically by the walk-away lock function. This function is disabled by the default setting. You can enable this function by the vehicle information display. For additional information, see "Vehicle Settings" (P.2-28).

NOTE:

- When the doors are locked by the walk-away lock function, the hazard indicator lights flash twice. Be sure to confirm the door locks before you leave the vehicle.**
- The walk-away lock function may not operate under the following conditions:**
 - When the door(s) and/or the liftgate are not closed securely.**
 - When the EV system is running.**
 - When the Intelligent Key is placed inside of the vehicle.**
 - When you place the Intelligent Key outside of the vehicle for a period of time. (When a door is opened and closed, the walk-away lock function will be activated.)**

12-VOLT BATTERY SAVER SYSTEM

When the following is met for a period of time, the battery saver system will cut off the power supply to prevent 12-volt battery discharge.

- The power switch is in the ON position. (See "Power switch positions" (P.5-15).)

WARNING LIGHTS AND AUDIBLE REMINDERS

To help prevent the vehicle from moving unexpectedly by erroneous operation of the Intelligent Key listed on the following chart or to help prevent the vehicle from being stolen, chime or beep sounds inside and outside the vehicle and the warning display appears on the vehicle information display.

When a chime or beep sounds or the warning display appears, be sure to check the vehicle and Intelligent Key.

See "Troubleshooting guide" (P.3-13) and "Vehicle information display" (P.2-22).

TROUBLESHOOTING GUIDE

Verify the location of all Intelligent Keys that are programmed for the vehicle. If another Intelligent Key is in range or inside the vehicle, the vehicle system may respond differently than expected.

	Symptom	Possible cause	Action to take
When closing the door after getting out of the vehicle	The No Key Detected warning appears on the display, the outside chime sounds 3 times and the inside warning chime sounds for a few seconds.	The power switch is in the READY to drive position.	Push and hold the power switch three times to the OFF position.
	The outside chime sounds continuously.	The power switch is in the OFF position, the electric shift control system has malfunctioned and the vehicle cannot be placed in the P (Park) position when the parking brake is not applied.	Make sure the parking brake is applied.
	The Rear Door Alert warning message appears on the display, the horn sounds three times, pauses, and sounds three more times, or a Check Rear Seat for All Articles warning appears on the display.	The Rear Door Alert is activated.	Check the rear seat for all articles, clear the Rear Door Alert warning message by using the steering switches.
When closing the door with the inside lock knob turned to LOCK	The outside chime sounds for a few seconds and all the doors UNLOCK.	The Intelligent Key is inside the vehicle or cargo area.	Carry the Intelligent Key with you.
When touching the lock sensor or pushing the liftgate request switch to lock doors	The outside chime sounds for a few seconds.	The Intelligent Key is inside the vehicle or a cargo area.	Carry the Intelligent Key with you.
When pushing the power switch in the READY to drive position	The Key Battery Low warning appears on the display.	The Intelligent Key battery charge is low.	Replace the battery with a new one. (See "Intelligent Key battery replacement" (P.8-13).)
	The No Key Detected warning appears on the display and the inside warning chime sounds for a few seconds.	The Intelligent Key is not in the vehicle.	Carry the Intelligent Key with you.

	Symptom	Possible cause	Action to take
When pushing the power switch	The Key System Error warning indicator appears on the display.	It warns of a malfunction with the Intelligent Key system.	It is recommended that you contact a NISSAN certified ARIYA dealer.

HOW TO USE REMOTE KEYLESS ENTRY FUNCTION



WARNING

- Radio waves could adversely affect electric medical equipment. Those who use a pacemaker should contact the electric medical equipment manufacturer for the possible influences before use.
- The Intelligent Key transmits radio waves when the buttons are pushed. The radio waves may affect aircraft navigation and communication systems. Do not operate the Intelligent Key while on an airplane. Make sure the buttons are not operated unintentionally when the unit is stored during a flight.



CAUTION

- Do not allow the Intelligent Key, which contains electrical components, to come into contact with water or salt water. This could affect the system function.

- Do not drop the Intelligent Key.
- Do not strike the Intelligent Key sharply against another object.
- Do not change or modify the Intelligent Key.
- Wetting may damage the Intelligent Key. If the Intelligent Key gets wet, immediately wipe until it is completely dry.
- If the outside temperature is below 14°F (-10°C) degrees, the battery of the Intelligent Key may not function properly.
- Do not place the Intelligent Key for an extended period in an area where temperatures exceed 140°F (60°C).
- Do not attach the Intelligent Key with a key holder that contains a magnet.
- Do not place the Intelligent Key near equipment that produces a magnetic field, such as a TV, audio equipment, personal computers, cellular phone or wireless charger.

The remote keyless entry function can operate all door locks using the remote keyless entry function of the Intelligent

Key. The remote keyless entry function can operate at a distance of approximately 33 ft (10 m) from the vehicle. (The operating distance depends upon the conditions around the vehicle.)

The remote keyless entry function will not operate:

- When the Intelligent Key is not within the operational range.
- When the Intelligent Key battery is discharged.



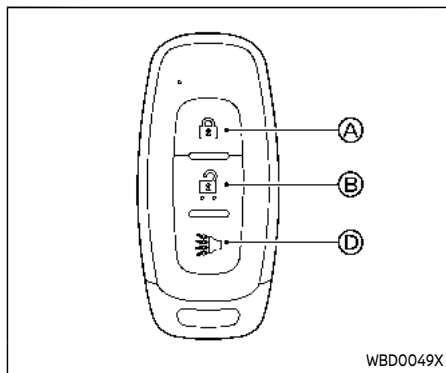

The remote keyless entry function can also operate the vehicle alarm.

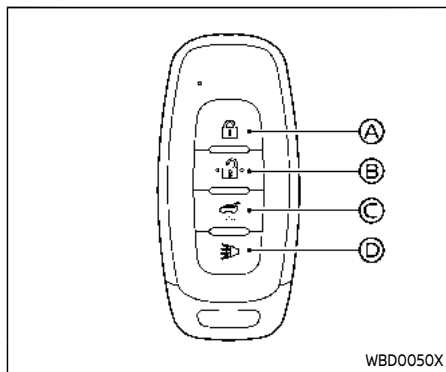

Type A (if so equipped)



Type B (if so equipped)

- (A) LOCK button 
- (B) UNLOCK button 
- (C) Power liftgate button 
- (D) PANIC button 

When you lock or unlock the doors or the liftgate, the hazard indicator will flash and the horn will sound as a confirmation. For details, see "Setting hazard indicator and horn mode" (P.3-18).



Locking doors

1. Place the power switch in the OFF position.
2. Carry the Intelligent Key with you.*
3. Close all the doors.
4. Push the LOCK  button (A) on the Intelligent Key.
5. All the doors and the liftgate will lock.
6. The hazard indicator flashes twice and the horn chirps once.

*: Doors will lock with the Intelligent Key while the power switch is in the ON position. The EV system will stop automatically.

Operate the door handles to confirm that the doors have been securely locked.

Unlocking doors

1. Push the UNLOCK  button (B) on the Intelligent Key once.
2. The hazard indicator flashes once. The driver's door will unlock.
3. Push the UNLOCK  button (B) again within 1 minute.
4. The hazard indicator flashes once. All the doors and the liftgate will unlock.

All doors will be locked automatically unless one of the following operations is performed within 1 minute after pushing the UNLOCK  button (B) while the doors are locked.

- Opening any door (including the liftgate).
- Pushing the power switch.

During this 1-minute time period, if the UNLOCK  button (B) is pushed, all doors will be locked automatically after another 1 minute.



NOTE:



The unlocking operation can be changed in "Selective Unlock" under the Vehicle Settings of the vehicle information display. For additional information, see "Vehicle Settings" (P.2-28).



Opening windows

The windows can be opened with the Intelligent Key. This function will not operate while the window timer is activated or the windows need to be initialized.

See "Power windows" (P.2-91).







To open the windows, push and hold the UNLOCK  button  on the Intelligent Key after the door is unlocked.

To stop opening, release the UNLOCK  button .



If the window open operation is stopped on the way while pushing the UNLOCK  button , release and push the button again until the window opens completely.

Opening moonroof (if so equipped)

The moonroof can be opened with the Intelligent Key. This function will not operate while the moonroof timer is activated or when the moonroof needs to be initialized.

To open the moonroof, push and hold the UNLOCK  button  on the Intelligent Key. The operation will stop after about 7 seconds. You can continue the operation by pushing and holding the UNLOCK  button  again. To stop opening, release the UNLOCK  button .





Opening/closing liftgate (if so equipped)

1. Push the power liftgate  button  for more than 1 second.
2. The liftgate will automatically open.

The outside chime sounds 3 times.



To close the liftgate, push the power liftgate  button  for more than 1 second.

The liftgate will automatically close.

If the  button  is pushed while the liftgate is being opened or closed, the liftgate will immediately stop. Pushing the  button  again will reverse the direction of the liftgate. However, when the liftgate is near the fully open position, it moves in the closing direction and when the liftgate is near the fully close position, it moves in the opening direction.

Using panic alarm

If you are near your vehicle and feel threatened, you may activate the alarm to call attention as follows:

1. Push the PANIC  button  on the Intelligent Key for **more than 0.5 seconds**.
2. The theft warning alarm and headlights will stay on for 25 seconds.

3. The panic alarm stops when:
 - It has run for 25 seconds, or
 - Any of the buttons on the Intelligent Key is pushed.

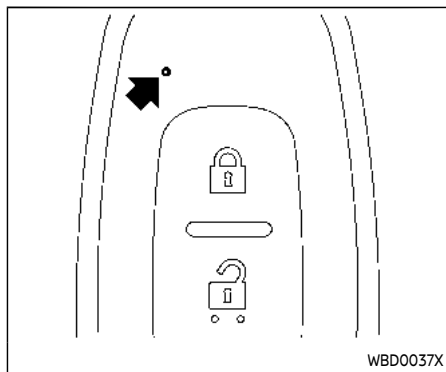





Intelligent Key button operation light

The light blinks only when you push any button on the Intelligent Key. The light illumination only signifies that the Intelligent Key has transmitted a signal. You may look and/or listen to verify that the vehicle has performed the intended operation. If the light does not blink, your battery may be too weak to communicate to the vehicle. If this occurs, the battery may need to be replaced.





For additional information regarding the replacement of a battery, see "Intelligent Key battery replacement" (P.8-13).

Setting hazard indicator and horn mode



This vehicle is set in hazard indicator and horn mode when you first receive the vehicle.

In hazard indicator and horn mode, when the LOCK  button  is pushed, the hazard indicator flashes twice and the horn chirps once. When the UNLOCK  button  is pushed, the hazard indicator flashes once.



If horns are not necessary, the system can be switched to the hazard indicator mode.

In hazard indicator mode, when the LOCK  button  is pushed, the hazard indicator flashes twice. When the UNLOCK  button  is pushed, neither the hazard indicator nor the horn operates.



Hazard indicator and horn mode:

Operation	DOOR LOCK	DOOR UNLOCK
Touching the lock or capacitive unlock sensor or liftgate request switch	HAZARD - twice OUTSIDE CHIME - twice	HAZARD - once OUTSIDE CHIME - once
Walk away lock or approach unlock	HAZARD - twice OUTSIDE CHIME - twice	HAZARD - once OUTSIDE CHIME - once
Pushing  or  button	HAZARD - twice HORN - once	HAZARD - once HORN - none

Hazard indicator mode:

Operation	DOOR LOCK	DOOR UNLOCK
Touching the lock or capacitive unlock sensor or liftgate request switch	HAZARD - twice OUTSIDE CHIME - none	HAZARD - none OUTSIDE CHIME - none
Walk away lock or approach unlock	HAZARD - twice OUTSIDE CHIME - none	HAZARD - once OUTSIDE CHIME - none
Pushing  or  button	HAZARD - twice HORN - none	HAZARD - none HORN - none

Switching procedure:

To switch the hazard indicator and horn (chime) operation, push the LOCK  and UNLOCK  buttons on the Intelligent Key simultaneously for more than 4 seconds.

- When the hazard indicator mode is set, the hazard indicator flashes 3 times.
- When the hazard indicator and horn mode is set, the hazard indicator flashes once and the horn chirps once.

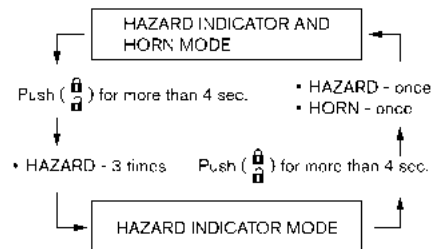

The horn operation can also be turned on or off in the vehicle information display. See "Vehicle Settings" (P.2-28).

HOOD

WARNING

- Make sure the hood is completely closed and latched before driving. Failure to do so could cause the hood to fly open and result in an accident.
- Never open the hood if steam or smoke is coming from the EV system compartment to avoid injury.

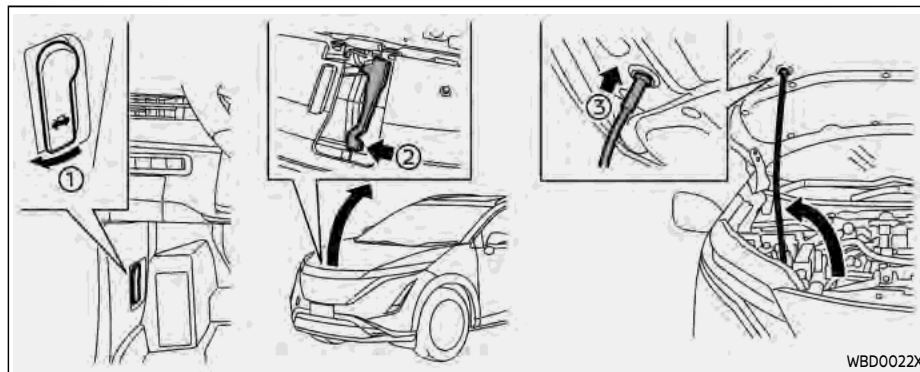

WBD0022X

1. Pull the hood lock release handle ① located below the driver's side instrument panel; the hood springs up slightly.
 2. Push the lever ② underneath the front of the hood sideways as illustrated with your fingertips.
 3. Raise the hood.
 4. Remove the support rod and insert it into the slot ③.
- then let it drop.
3. Make sure it is securely latched.

When closing the hood:

1. While supporting the hood, return the support rod to its original position.
2. Slowly lower the hood to about 8 to 12 in (20 to 30 cm) above the hood lock,

LIFTGATE

WARNING

- Always be sure the liftgate has been closed securely to prevent it from opening while driving.
- Do not drive with the liftgate open.
- To help avoid risk of injury or death through unintended operation of the vehicle and or its systems, including entrapment in windows or inadvertent door lock activation, do not leave children, people who require the assistance of others or pets unattended in your vehicle. Additionally, the temperature inside a closed vehicle on a warm day can quickly become high enough to cause a significant risk of injury or death to people and pets.
- Always be sure that hands and feet are clear of the door frame to avoid injury while closing the liftgate.

CAUTION

Do not use accessory carriers that attach to the liftgate. Doing so will cause damage to the vehicle.

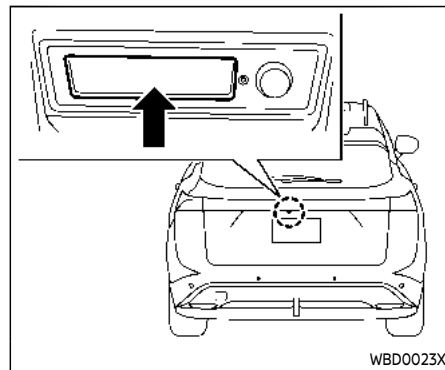

OPERATING MANUAL LIFTGATE (if so equipped)

To open the liftgate, unlock it. Pull up the liftgate to open.

The liftgate can be unlocked by:

- pushing the UNLOCK  button on the Intelligent Key once (all door unlock mode) or twice (selective door unlock mode).
- pushing the liftgate request switch.
- touching the capacitive unlock sensor (all door unlock mode).

To close the liftgate, pull down until it securely locks.

OPERATING POWER LIFTGATE (if so equipped)

To operate the power liftgate, the vehicle must be in the P (Park) position.

The power liftgate will not operate if the battery voltage is low.

If the liftgate is open approximately 5.9 in (150 mm) or less from the fully closed position, power liftgate cannot be performed by any switch operations. To operate the power liftgate, manually close the liftgate.

The power liftgate operation can be activated or deactivated in the vehicle information display. (See "Vehicle Settings" (P.2-28).)

NOTE:

- For models with motion-activated liftgate: When washing, waxing or maintaining your vehicle, placing or replacing the body cover, or splashing water to the area around the kick motion sensor, turn off the power liftgate.
- If the power open or close operation is performed consecutively, the safety mode activates and the operation cannot be performed for a certain period of time. In this case, wait for a while and then perform the operation.

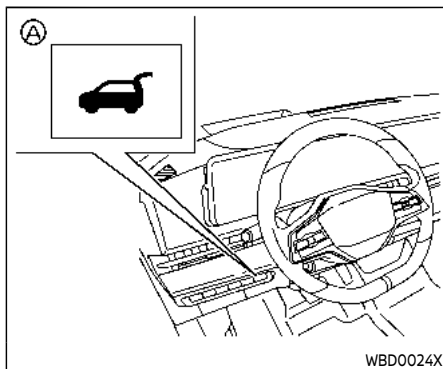

Power liftgate switch – Instrument panel

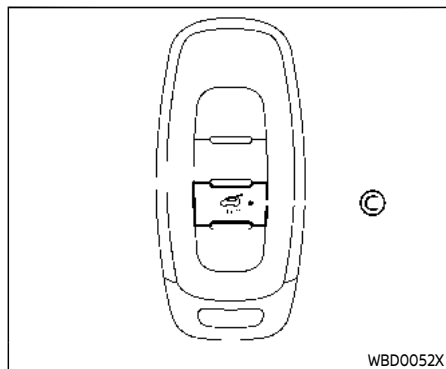

Power liftgate button - Key (example)

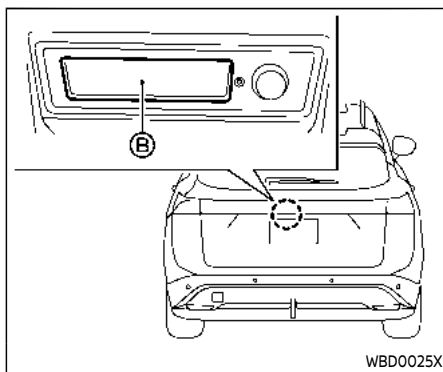

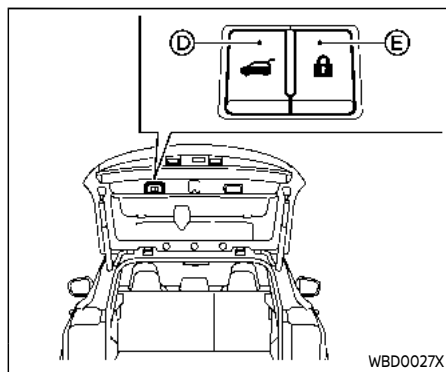

Liftgate opener switch



Power liftgate close and lock switches – Liftgate



Power open (using switches)

When the liftgate is fully closed, the liftgate will fully open automatically by:

- pushing the power liftgate switch  on the instrument panel for more than 1 second
- pushing the liftgate opener switch 
- pushing the power liftgate button  on the key for more than 1 second

The outside chime sounds when the liftgate starts opening.



NOTE:

The liftgate can be opened by the power liftgate switch  or the power liftgate button  even if the liftgate is locked. The liftgate can be unlocked and opened independently of the other doors, even when they are locked. The liftgate must be unlocked (or the Intelligent Key must be within range) to open with the liftgate opener switch .

Power close (using switches)

When the liftgate is fully opened, the liftgate will fully close automatically by:

- pushing the power liftgate switch  on the instrument panel for more than 1 second

- pushing the power liftgate button  on the key for more than 1 second
- pushing the power liftgate close switch  on the lower part of the liftgate

The outside chime sounds when the liftgate starts closing.





Power close and lock

When the liftgate is fully opened and the Intelligent Key is carried with you near the liftgate, all the doors and the liftgate will lock and the liftgate will fully close automatically by pushing the power liftgate lock switch  on the lower part of the liftgate.

The outside chime sounds when the liftgate starts closing.

Stop and reverse function (if so equipped)

The power liftgate will stop immediately if one of the following actions is performed during power open or close.

- pushing the power liftgate switch 
- pushing the liftgate opener switch 
- pushing the power liftgate close switch  on the lower part of the liftgate
- pushing the power liftgate button  on the key

And then the power liftgate will move in the reverse direction if one of the above actions is performed again.

The outside chime sounds when the liftgate starts to reverse.

Auto reverse function

The auto-reverse function enables the liftgate to automatically reverse when something is caught in the liftgate as it is opening or closing. When the control unit detects an obstacle, the liftgate will reverse and stop.

If a second obstacle is detected, the liftgate motion will stop.

A pinch sensor is mounted on each side of the liftgate. If an obstacle is detected by the pinch sensor during power close, the liftgate will reverse and stop.

NOTE:

If the pinch sensor is damaged or removed, the power close function will not operate.



WARNING

There is a small distance immediately before the closed position that cannot be detected. Make sure that all passengers keep their hands, etc., clear from the liftgate opening be-

fore closing the liftgate.

Manual mode

If power operation is not available, the liftgate can be operated manually. Power operation may not be available if the battery voltage is low or if the liftgate is open approximately 5.9 in (150 mm) or less from the fully closed position. When the power liftgate is turned off, the liftgate can be opened manually by pushing the liftgate opener switch. If the power liftgate opener switch is pushed during power open or close, the power operation will be canceled and the liftgate can be operated manually. This will allow normal power operation functions to resume.

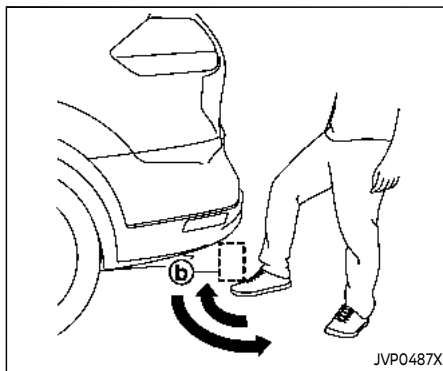
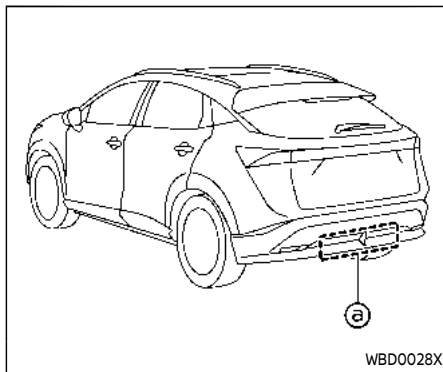

MOTION-ACTIVATED LIFTGATE (if so equipped)

The liftgate can be operated using a quick kicking motion under the center of the rear bumper.

The kick motion sensor (a) is located on the back of the rear bumper. when you move your foot under and then away from the operating range (b) similar to a kicking motion, while carrying the Intelligent Key with you, the liftgate will open or close automatically.

Proper operation technique

- While at the rear of the vehicle, begin making a quick forward kicking motion.
- Raise your foot straight under the center of the rear bumper then immediately return your foot to the ground in a continuous motion.
- You do not need to hold your foot under the bumper or move it side to side. Immediately return your foot to the ground.
- The kicking motion should be straight, smooth and consistent.
- After your kick motion is complete, step back and allow the liftgate to open/close.

- Three beeps will sound and the liftgate will begin moving within 2 seconds after the kick.



WARNING

Prevent unintentional liftgate opening/closing. There may be conditions when opening/closing the liftgate is not desired. Keep the Intelligent Key out of range of the liftgate, 7 ft (2 m) or more or inside the vehicle, when washing or working around the back of the vehicle.

NOTE:

- **The kick motion sensor may not function under the following conditions:**
 - **When operating near a location where strong radio waves are transmitted, such as a TV tower, power station or broadcasting station.**
 - **When the vehicle is parked near a parking meter.**
- **The power liftgate may not operate when your foot remains in the operating range .**



CAUTION

- **When the Intelligent Key is carried with you near the liftgate, even someone, who does not carry the Intelligent Key, may be able to open or close the liftgate with a kick motion.**
- **Do not perform a kick motion on an unstable place (for example, on a slope or a muddy ground, etc.).**

Power open or close function

The liftgate will fully open automatically using the kick motion sensor.

1. Carry the Intelligent Key.
2. Move your foot under and away from the rear bumper similarly to a kicking motion within the operation range of the kick motion sensor.
3. The liftgate will automatically open or close.

Stop and reverse function

The power liftgate will stop immediately if a kick motion is performed during power open or close. The liftgate can be stopped even if you do not carry the Intelligent Key.

And then the power liftgate will move in the reverse direction if a kick motion is performed again. The power liftgate can be reversed when you carry the Intelligent Key.

GARAGE MODE SYSTEM (if so equipped)

The liftgate can be set to open to a specific height by performing the following:

1. Open the liftgate.
2. Pull the liftgate down to the desired position and hold the liftgate (the liftgate will have some resistance when being manually adjusted).
3. While holding the liftgate in position, press and hold the power liftgate close and lock switch  located on the liftgate for approximately 3 seconds or until 2 beeps are heard.

The liftgate will open to the selected position setting. To change the position of the liftgate, repeat steps 1-3 for setting the position of the liftgate.

CAUTION

Do not set the height of the liftgate below approximately 1/3 of the way to the floor using garage mode. Even if you set the height below approximately 1/3 of the way to the floor, the height will automatically be set to approximately 1/3 of the way to the floor.

- Do not let children operate the liftgate.

AUTO CLOSURE (if so equipped)

When the liftgate reaches the secondary position, the closure motor engages and pulls the liftgate to its primary latch position.

Do not apply excessive force when the auto closure is operating. Excessive force applied may cause the mechanism to malfunction.

CAUTION

- The liftgate will automatically close from the secondary position. To avoid pinching, keep hands and fingers away from liftgate opening.

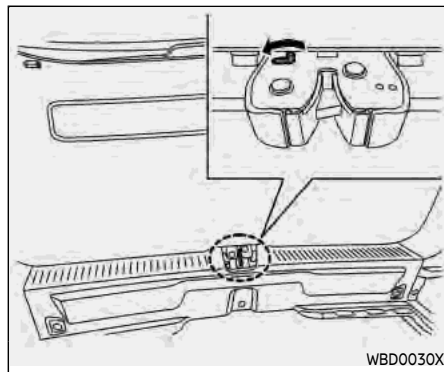

LIFTGATE RELEASE LEVER

If the liftgate cannot be opened with the power door lock switch due to a discharged 12-volt battery, follow these steps.

1. Fold the rear seats down. (See "Rear seats" (P.1-7).)
2. Insert a suitable tool in the access opening. Move the release lever to the left. The liftgate will be unlatched.
3. Push the liftgate up to open.

It is recommended that you contact a NISSAN certified ARIYA dealer as soon as possible for repair.

CHARGE PORT LID

OPENING CHARGE PORT LID

CAUTION

Make sure that the charge port lid is completely closed and latched before driving. Failure to do so could cause the lid to open suddenly during driving.

The charge port lid is linked to the door locking mechanism of the vehicle.

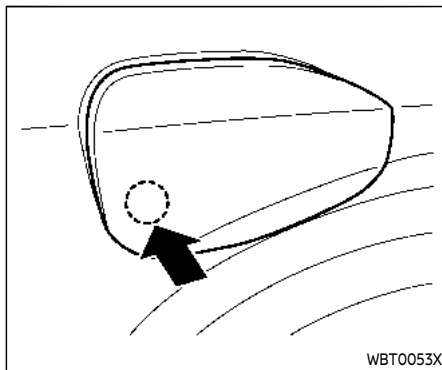

To open the charge port lid, unlock the doors and push the rear part of the lid as illustrated.

When closing the charge port lid, push the lid to latch it.

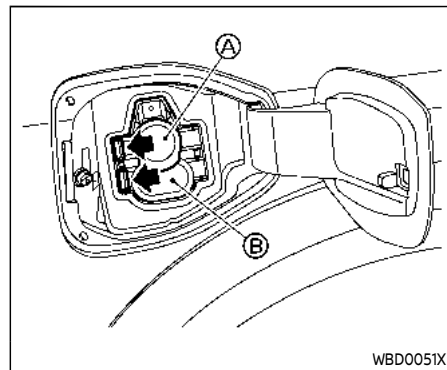

Ⓐ: Normal charge

Ⓑ: Quick charge

CHARGE PORT CAP

When opening the charge port cap, push the tab and open the cap.

When the charge port cap is closed to its previous position, it will lock automatically.

CAUTION

- When charging is finished, be sure to close the charge port cap. If water or dust gets inside the charge port, this may cause a

malfunction.

- Pay particular attention when using the normal charge port as the charge port lid can be closed even when the normal charge port cap is open.
- Close the quick charge port cap before closing the charge port lid. The quick charge port cap can be damaged if it is open when closing the charge port lid.
- If the charge port lid is closed after vehicle's door has been locked, the charge port lid is not locked. Be sure that firstly close the lid and then lock the vehicle.

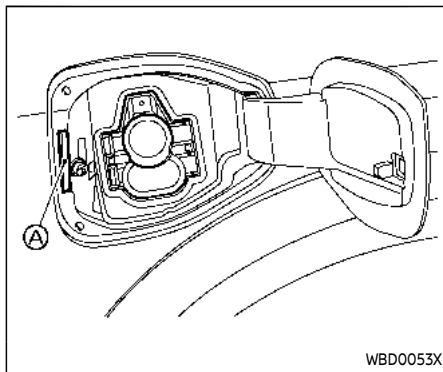

Ⓐ Charge port light

CHARGE PORT LIGHT

The charge port has a light. The charge port light illuminates as follows.

When the normal or trickle charging starts

- When you approach the vehicle while the vehicle doors are locked with the Intelligent Key with you or unlock the vehicle, the light illuminates for about 3 minutes.
- When the charge connector is connected, the light turns off.

When the charge connector lock mode has been changed to LOCK or AUTO, the

light will turn off after connecting the charge cable and the charge connector is locked.

When the normal or trickle charging finished

- When you approach the vehicle while the vehicle doors are locked with the Intelligent Key with you or unlock the vehicle, the light illuminates for about 30 seconds.
 - If the charge connector is not disconnected, the connector will be locked again after about 30 seconds.When the charge connector lock mode has been changed to LOCK or AUTO;
 - The light will turn on after the charge connector lock is unlocked.
 - The light will turn off after the charge connector lock is locked.
- When the charge connector is disconnected, the light illuminates for about 30 seconds.

NOTE:

If you walk away from the vehicle with the Intelligent Key with you, the light illuminates for about 30 seconds. If the light has already been illuminated, the light turns off after about 30 seconds.

TILT/TELESCOPIC STEERING

WARNING

- Do not adjust the steering wheel while driving. You could lose control of your vehicle and cause an accident.
- Do not adjust the steering wheel any closer to you than is necessary for proper steering operation and comfort. The driver's air bag inflates with great force. If you are unrestrained, leaning forward, sitting sideways or out of position in any way, you are at greater risk of injury or death in a crash. You may also receive serious or fatal injuries from the air bag if you are up against it when it inflates. Always sit back against the seatback and as far away as practical from the steering wheel. Always use the seat belts.

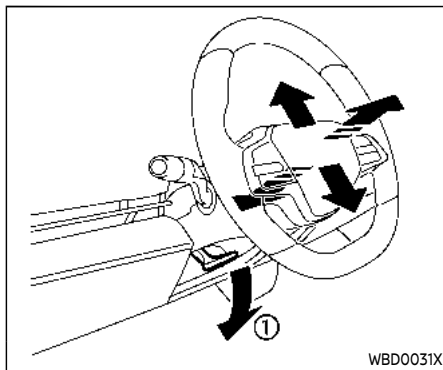

MANUAL STEERING WHEEL ADJUSTMENT

Tilt and telescopic operation

Pull the lock lever ① down and adjust the steering wheel up, down, forward or rearward to the desired position. Push the lock lever up securely to lock the steering wheel in place.

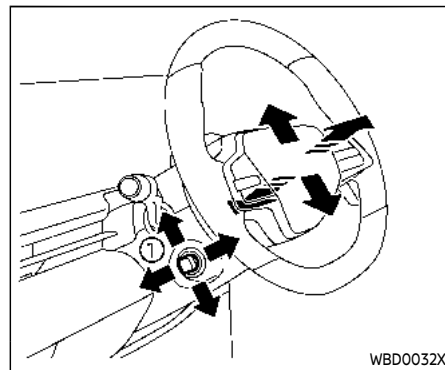

ELECTRIC STEERING WHEEL ADJUSTMENT

Tilt and telescopic operation

Move the lever ① to adjust the steering wheel up or down, forward or rearward until the desired position is achieved.

Entry/Exit function

The memory seat system will make the steering wheel move up automatically when the driver's door is opened with the power switch in the "OFF" position. This function allows the driver get into and out of the seat more easily.

SUN VISORS

For more information, see "Memory seat" (P.3-41).

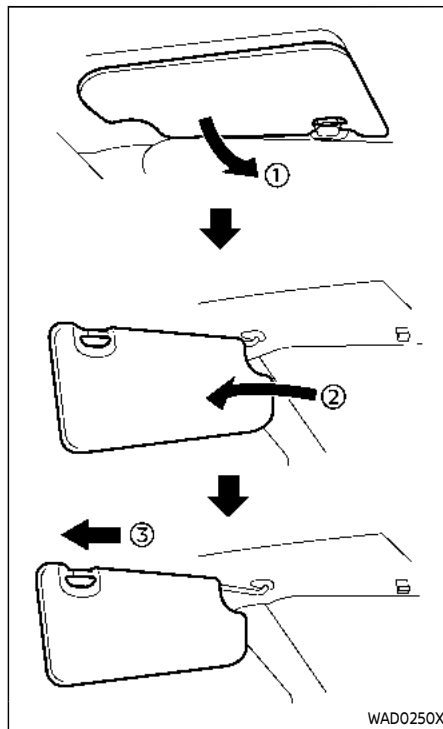

1. To block glare from the front, swing down the main sun visor ①.

2. To block glare from the side, remove the main sun visor from the center mount and swing it to the side ②.
3. Slide the sun visor ③ in or out as needed.

CAUTION

- Do not store the sun visor before returning the extension to its original position.
- Do not pull the extension sun visor forcibly downward.

MIRRORS

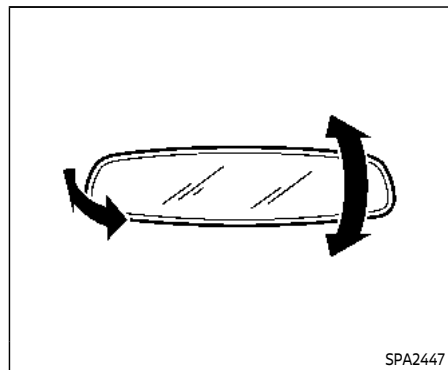

INSIDE MIRROR

Adjust the angle of the inside mirror to the desired position.

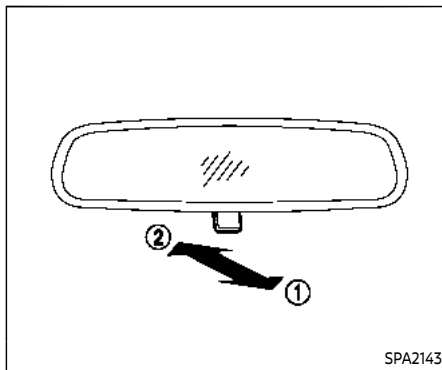

Manual anti-glare type (if so equipped)

The night position ① will reduce glare from the headlights of vehicles behind you at night.

Use the day position ② when driving in daylight hours.



WARNING

Use the night position only when necessary, because it reduces rear view clarity.

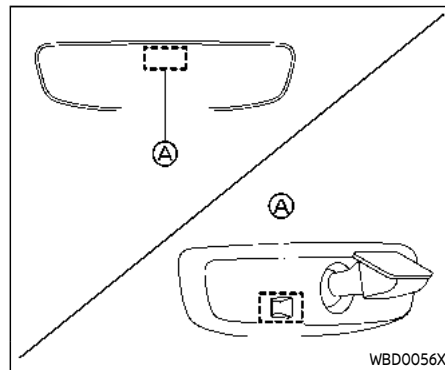

Automatic anti-glare type (if so equipped)

The inside mirror is designed so that it automatically changes reflection according to the intensity of the headlights of the following vehicle.

The anti-glare system will be automatically turned on when the power switch is placed in the ON position.

Do not hang any objects on the mirror or apply glass cleaner. Doing so will reduce the sensitivity of the sensor (A), resulting in improper operation.

Intelligent Rear View Mirror (if so equipped)



WARNING

Failure to follow the warnings and instructions for proper use of the Intelligent Rear View Mirror could result in serious injury or death.

- The Intelligent Rear View Mirror is a convenience feature but it is not a substitute for proper vehicle operation. The system has areas where objects cannot be viewed. Check the blind spot of the Intelligent Rear View Mirror before vehicle operation. The driver is always responsible for safe driving.
- Do not disassemble or modify the Intelligent Rear View Mirror, the camera unit or wirings. If you do, it may result in accidents or fire. In case you notice smoke or smell coming from the Intelligent Rear View Mirror, stop using the system immediately. It is recommended that you visit a NISSAN certified ARIYA dealer for servicing.

- Do not operate the Intelligent Rear View Mirror while driving. Doing so can be a distraction and it could lose control of your vehicle and cause an accident or serious injury.
- Do not gaze into the Intelligent Rear View Mirror display during driving. It may cause a distraction and it could lose control of your vehicle and cause an accident or serious injury. Gazing into the display screen during driving also can be a cause of carsick for passengers.
- Do not put a cigarette or flames to the Intelligent Rear View Mirror, the camera unit or wirings. It may cause a fire.
- Be sure to adjust the Intelligent Rear View Mirror before driving. Switch the system to the conventional rearview mirror mode and be properly seated on the driver's seat. Then adjust the rearview mirror so as to see the rear window properly. Driving without adjusting the rearview mirror may cause difficulty in watching the display at Intelligent Rear View Mirror mode (camera view mode) due to the reflection from

the surface of the mirror.

- If the indicator light of the mirror turns off at the Intelligent Rear View Mirror mode (camera view mode), immediately switch the system to the conventional rearview mirror mode. If the indicator light does not illuminate after switching to the Intelligent Rear View Mirror mode again, the system may malfunction. Have the system checked. It is recommended that you visit a NISSAN certified ARIYA dealer.
- If the Intelligent Rear View Mirror malfunctions, immediately switch the system to the conventional rearview mirror mode. Have the system checked. It is recommended that you visit a NISSAN certified ARIYA dealer.
- When strong light (for example, sunlight or high beams from following vehicles) enters the camera, a light beam or a glaring light may appear on the display screen of the Intelligent Rear View Mirror. In that case, switch the system to the conventional rearview mirror mode appropriately.

- If dirt, rain or snow accumulates on the exterior glass surface covering the camera, the Intelligent Rear View Mirror may not display objects clearly. Use of the rear window wiper/washer may improve visibility, but if not, switch the Intelligent Rear View Mirror to the conventional rearview mirror mode until a time the glass covering the camera can be cleaned.

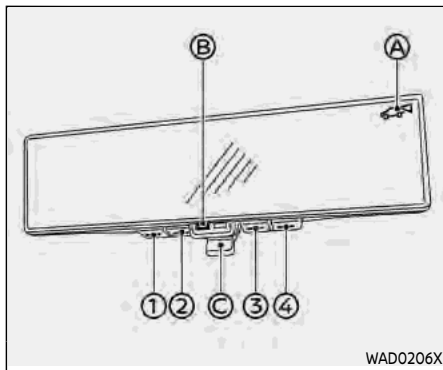

- ① MENU button
- ② Second button
- ③ Third button
- ④ Fourth button
- Ⓐ Indicator
- Ⓑ Indicator light
- Ⓒ Mode select lever

Components:

Intelligent Rear View Mirror provides a clear rearview from a camera located on the rear of the vehicle. Intelligent Rear View Mirror has two modes: conventional rearview mirror mode and Intelligent Rear View Mirror mode (camera view mode). You can switch these two modes by the mode select lever Ⓒ.

When the Intelligent Rear View Mirror mode is selected, the indicator Ⓐ is displayed, and the indicator light Ⓑ illuminates. (If a malfunction occurs in the Intelligent Rear View Mirror, the indicator Ⓐ will turn off or not appear when the Intelligent Rear View Mirror mode is selected.)

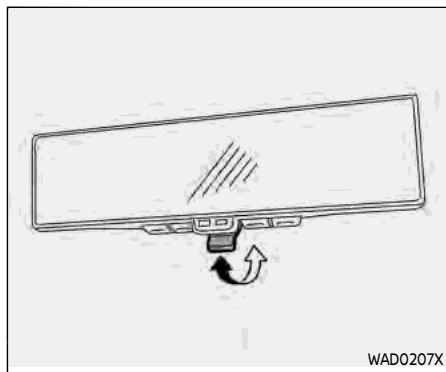

How to change the mode:

The mode can be switched when the power switch is in the "ON" position.

- Pull the mode select lever to switch to the Intelligent Rear View Mirror mode (camera view mode).
- Push the mode select lever to switch to the conventional rearview mirror mode.

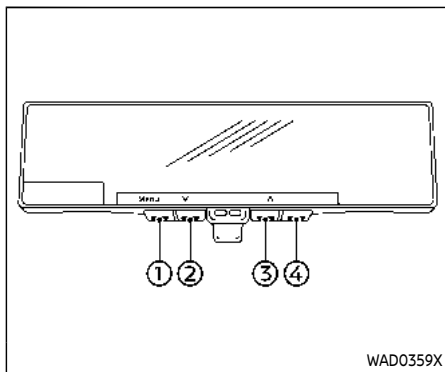

How to make settings of Intelligent Rear View Mirror (MENU button operation):

You can choose display settings of the Intelligent Rear View Mirror such as brightness, camera angle and textual indication ON or OFF.

When the Intelligent Rear View Mirror mode (camera view mode) is on, push the MENU button ① to display the setting menu. The following items can be adjusted:

- Brightness
- Down/Up
- Left/Right

- Rotation
- Indication
- Language
- Switch Backlight
- License

Push ② or ③ button to select an item and then push the ④ button.

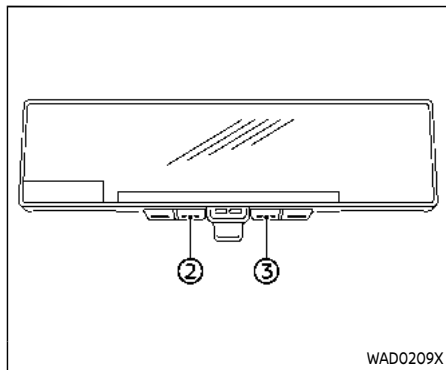

Brightness

The brightness of the display screen can be adjusted.

- Push the button ② to dim the screen.
- Push the button ③ to brighten the screen.

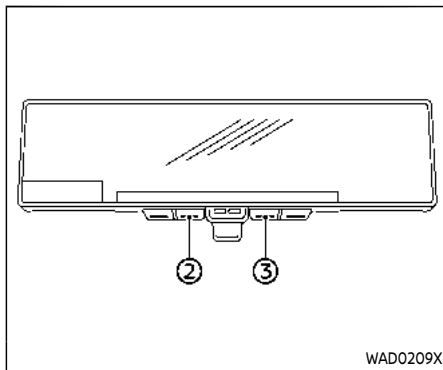

Down/Up

The vertical camera angle of the display screen can be adjusted.

- Push the button ② to down the camera angle.
- Push the button ③ to up the camera angle.

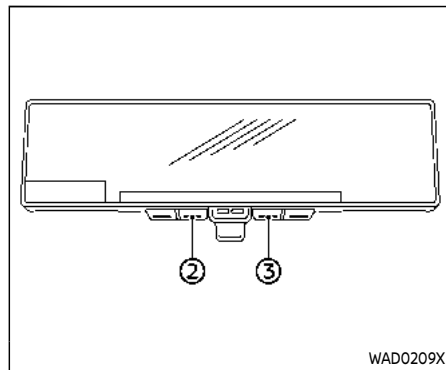

Left/Right

The horizontal camera angle of the display screen can be adjusted.

- Push the button ② to move the camera angle to the left.
- Push the button ③ to move the camera angle to the right.

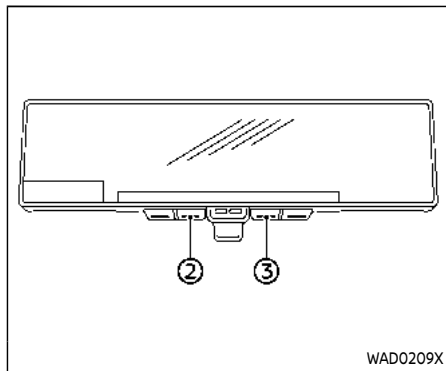

Rotation

The camera angle of the display screen can be rotated.

- Push the button ② to rotate the camera angle to the left.
- Push the button ③ to rotate the camera angle to the right.

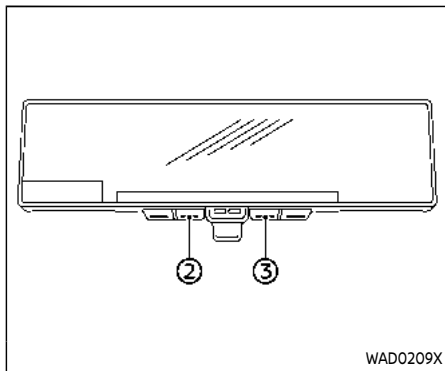

Indication

The textual indication can be turned on or off on the Intelligent Rear View Mirror display screen.

- Push the button ② to disable the textual indication on the display screen.
- Push the button ③ to enable the textual indication on the display screen.

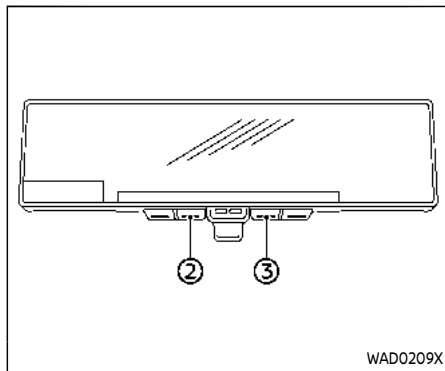

Language

You can select the language of the textual indication on the Intelligent Rear View Mirror display screen.

Select the language by using the ② or ③ button. The language setting will be retained even if the EV system is restarted.

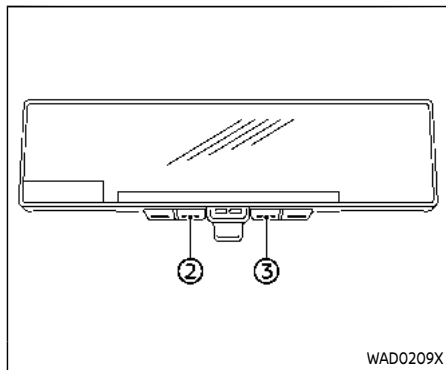

Switch Backlight

The illumination of the buttons can be turned on or off.

- Push the button ② to turn off the illumination.
- Push the button ③ to turn on the illumination.

License

The license information is displayed.

Intelligent Rear View Mirror system precautions:

NOTE:

- Long-term use of this system in stopping EV system may cause battery to be discharged.
- Do not attach an antenna of wireless device near the Intelligent Rear View Mirror. Electric wave from wireless device may cause disturbed image in the Intelligent Rear View Mirror.
- Do not push the buttons excessively or operating the lever roughly may cause a system failure or the Intelligent Rear View Mirror itself to drop.
- Never turn the body of Intelligent Rear View Mirror horizontally by 20° or more, or vertically by 30° or more. It may damage the Intelligent Rear View Mirror.
- Do not apply strong shocks to the body of Intelligent Rear View Mirror. It may cause a system failure.
- Do not apply heavy load to the camera and camera-cover on the rear of the vehicle. It may cause the camera to be removed or may cause a system failure.
- If it is difficult to see the Intelligent Rear View Mirror display screen because of a strong external light, switch the mode to the conventional

rearview mirror mode for better use.

- When LED headlights are viewed on the Intelligent Rear View Mirror display, the images may flicker. This is normal.
- Due to diffused reflection from external environment, images on the screen may flicker. This is not a malfunction.
- A quick movement of a thing may not be able to display on the camera view screen. This is not a malfunction.
- Turn on the headlights at twilight or in a tunnel, etc. When headlights are turned on, the display and the camera systems automatically switched to the night mode, which can prevent dazzling.
- The Intelligent Rear View Mirror mode (camera view mode) display is different from the conventional rearview mirror. Objects in the display may differ from actual distance. Do not solely rely on the Intelligent Rear View Mirror. Always rely on your own operation to avoid accidents.
- Immediately after the Intelligent Rear View Mirror is switched from one mode to another, you may have difficulty in focusing on the image in

the mirror/display screen with your eyes. Be cautious using the Intelligent Rear View Mirror until your eyes get accustomed to the selected mode. If it is necessary to correct eye focusing, the use of multifocal glasses, etc. is recommended.

- It may take time for you to focus on the camera view display depending on your condition.
- If the brightness of the camera view display is adjusted to excessive bright level, it may cause an eye-strain in the driving. Adjust the brightness properly.
- Use the rear window wiper when it rains. If the camera view image is still unclear when the rear window wiper is in operation, check the deterioration of the rear window wiper blade.
- When using the rear window wiper, images on the screen may flicker. This is not a malfunction.
- Defog the rear window with defroster when rear window is fogged. Use the conventional rearview mirror mode until the rear window is fully defogged.
- The display of the Intelligent Rear View Mirror may become hot. This is not a malfunction.

- **The color of an object in the distance or in the dark may be difficult to be recognized. This is not a malfunction.**
- **When the temperature is high, the brightness may be decreased or image may not be displayed on the camera view display. This is not a malfunction.**
- **When the temperature is low, the image may be distorted on the camera view display. This is not a malfunction.**

System maintenance (Intelligent Rear View Mirror):

- Always keep the mirror and camera area of the rear window clean.
- Clean the mirror and the camera lens with a dry soft cloth.
- When cleaning the camera area of the rear window, use a soft cloth dampened with water and a few neutral detergent. And after that, dry it up with dry soft cloth.
- If the image on the Intelligent Rear View Mirror display screen is still unclear even after cleaning the camera area of the rear window, an oil film may be adhering to the rear window glass. Clean the rear window glass with an oil film remover.

- Never use alcohol, benzine, thinner, or any similar material to clean the mirror or camera lens. It will cause a discoloration, deterioration or a system malfunction.
- Do not cover the front of the mirror. It may interfere with brightness adjustment or switching images on the camera view display.
- Do not attach a sticker (including transparent material) on the camera area of the rear window.

OUTSIDE MIRRORS



WARNING

Objects viewed in the outside mirror on the passenger side are closer than they appear. Be careful when moving to the right. Using only this mirror could cause an accident. Use the inside mirror or glance over your shoulder to properly judge distances to other objects.

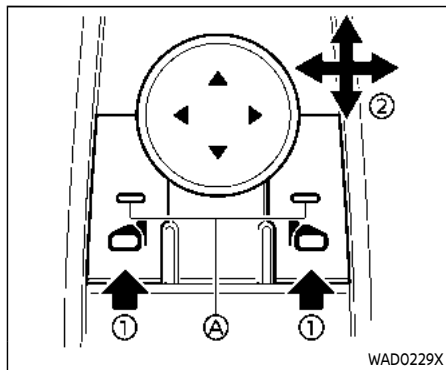

Adjusting outside mirrors

The outside mirror control switch is located on the driver's armrest.

The outside mirror will operate only when the power switch is in the ON position.

Push either the right or left switch to select the right or left side mirror ① (the indicator light ② on the selected mirror switch illuminates), then adjust ③ using the control switch.

Defrosting outside mirrors

The outside mirrors will be heated when the rear window defroster switch is operated. (See "Rear window and outside mirror defroster switch" (P.2-60).)

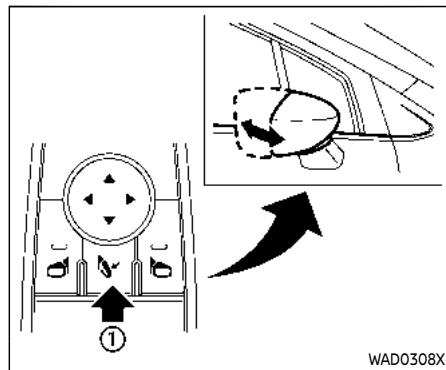

Example

Foldable outside mirrors

The outside rearview mirror remote control operates when the power switch is in the ON position.

The outside rearview mirrors automatically fold when the outside rearview mirror folding switch ① is pushed in. To unfold, push the switch again.



CAUTION

- Continuously performing the fold/unfold operation of the outside rearview mirror may cause the switch to stop the operation.

- **Do not touch the mirrors while they are moving. Your hand may be pinched, and the mirror may malfunction.**
- **Do not drive with the mirrors stored. You will be unable to see behind the vehicle.**
- **If the mirrors were folded or unfolded by hand, there is a chance that the mirror will move forward or backward during driving. If the mirrors were folded or unfolded by hand, be sure to adjust them again electrically before driving.**

Automatic fold:

The outside rearview mirrors automatically fold when the doors are locked with the Intelligent Key, the lock sensors or the request switch. The mirrors unfold when the doors are unlocked with the Intelligent Key, the capacitive unlock sensors or the request switch, or when the power switch is placed in the ON position. For information about disabling the automatic fold function, see "Vehicle Settings" (P.2-28).

Reverse tilt-down feature (if so equipped)

When backing up the vehicle, the right or left outside mirror will turn downward automatically to provide better rear visibility.

1. Place the power switch in the ON position.
2. Move the shift lever to the R (Reverse) position.
3. Choose the right or left outside mirror by operating the outside mirror control switch.
4. The selected outside mirror surface moves downward.

For setting the position of the outside mirror surface, perform the following steps.

1. Choose the right or left outside mirror by operating the outside mirror control switch.
2. Move the shift lever to the R (Reverse) position.
3. Adjust the outside mirror surface to the desired position. (See "Adjusting outside mirrors" (P.3-39).)
4. Move the shift lever to the P (Park) or D (Drive) position.

5. The adjusted mirror position will be set.

When one of the following conditions has occurred, the outside mirror surface will return to its original position.

- The shift lever is moved out of the R (Reverse) position for a short period of time when the vehicle speed is lower than 5 MPH (8 km/h).
- The vehicle speed exceeds 5 MPH (8 km/h).
- The selected outside mirror is deselected using the outside mirror control switch.
- The power switch is placed in the OFF position.
- The EV system is stopped.

MEMORY SEAT (if so equipped)

The memory seat system has the following features:

- Memory storage function
- Entry/exit function

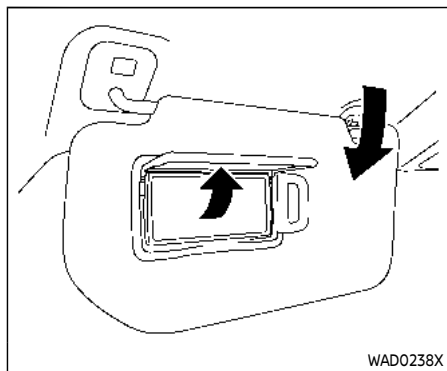

VANITY MIRROR

To use the vanity mirror, pull down the sun visor and pull up the cover.

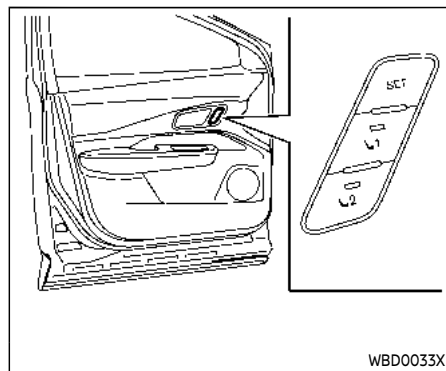

Memory seat switch (driver's side shown; passenger side similar)

MEMORY STORAGE FUNCTION

Two positions for the driver's seat, front passenger's seat (if so equipped), steering wheel and outside mirrors can be stored in the memory switch. Follow these procedures to use the memory system.

1. Adjust the driver's seat, front passenger's seat (if so equipped), steering wheel and outside mirrors to the desired positions by manually operating each adjusting switch. For additional information, refer to "Seats" (P.1-3), "Tilt/telescopic steering" (P.3-29) and "Outside mirrors" (P.3-38).

2. Push the SET switch and, within 5 seconds, push the memory switch (1 or 2).
3. The indicator light for the pushed memory switch will come on and stay on for approximately 5 seconds.
4. The chime will sound if the memory has been stored.

NOTE:

If a new memory position is stored in the same memory switch, the previous memory position will be overwritten by the new stored position.

Confirming memory storage

Push the SET switch. If a memory position has been stored in the switch (1 or 2) then the indicator light for the respective switch will stay ON for approximately 5 seconds.

Recalling switch memory positions

To recall the manually stored positions, push the memory switch (1 or 2). The driver's seat, front passenger's seat (if so equipped), steering wheel and the outside mirrors will move to the positions stored in the memory switch.

The lumbar support (4 way type - if so equipped) may not move to the stored position depending on the conditions.

Linking log-in function to a stored memory position

The log-in function can be linked to a stored memory position with the following procedure.

1. Place the power switch in the ON position while carrying the Intelligent Key that was registered to the vehicle with a log-in function.

NOTE:

Make sure the single Intelligent Key is inside the vehicle. If multiple keys are inside the vehicle, the vehicle may detect a wrong Intelligent Key.

2. Adjust the position of the driver's seat, steering wheel and outside mirrors. (See "Seats" (P.1-3), "Tilt/telescopic steering" (P.3-29) and "Outside mirrors" (P.3-38).)
3. Place the power switch in the OFF position.

The next time you log in (selecting the user on the display) after placing the power switch in the ON position while carrying the Intelligent Key, the system will automatically adjust to the memorized driving position. (See the separate NissanConnect® Owner's Manual.)

ENTRY/EXIT FUNCTION

This system is designed so that the driver's seat and steering wheel will automatically move when the shift position is in the P (Park) position. This allows the driver to get into and out of the driver's seat more easily.

The driver's seat will slide backward and the steering wheel will move up:

- When the driver's door is opened with the power switch placed in the OFF position.
- When the power switch is changed from ON to OFF with the driver's door open.

The driver's seat and steering wheel will return to the previous position:

- When the power switch is placed in the ON position while the shift position is in the P (Park) position.

The entry/exit function can be canceled through "Vehicle Settings" in the vehicle information display by performing the following:

- Switch the "Exit Seat Slide" or "Exit Steering Up" from ON to OFF. For additional information, refer to "Vehicle Settings" (P.2-28).

SYSTEM OPERATION

The memory seat system will not work or will stop operating under the following conditions:

- When the vehicle speed is 4 MPH (7 km/h).
- When any of the memory switches are pushed while the memory seat system is operating.
- When the switch for the driver's seat, front passenger's seat (if so equipped) steering wheel or power sliding function of the console box is pushed while the memory seat system is operating.
- When the seat, steering wheel and outside mirrors have already been moved to the memorized position.
- When no seat position is stored in the memory switch.
- When the shift lever is moved from P (Park) to any other position.

MEMO

4 Monitor, heater, air conditioner, audio and phone systems

NissanConnect® Owner's Manual	4-2	Intelligent Around View® Monitor	
Safety precautions	4-2	system limitations	4-20
RearView Monitor (if so equipped)	4-3	System maintenance	4-22
RearView Monitor system operation	4-4	Moving Object Detection (MOD) (if	
How to read the displayed lines	4-5	so equipped)	4-23
Difference between predictive and		MOD system operation	4-24
actual distances	4-5	Turning MOD on and off	4-25
How to park with predictive course lines	4-7	MOD system limitations	4-25
Adjusting the screen	4-8	System maintenance	4-26
How to turn on and off predictive		Ventilators	4-27
course lines	4-9	Center ventilators	4-27
RearView Monitor system limitations	4-9	Side ventilators	4-27
System maintenance	4-10	Rear ventilators	4-28
Intelligent Around View® Monitor (if		Heater and air conditioner	4-28
so equipped)	4-11	Automatic air conditioner	4-29
Intelligent Around View® Monitor		Air conditioner settings	4-33
system operation	4-12	Adjusting button sensitivity	4-34
Difference between predictive and		Operating tips	4-34
actual distances	4-16	Climate Ctrl. Timer	4-35
How to park with predictive course lines	4-17	Servicing air conditioner	4-37
How to switch the display	4-19	Radio antenna	4-38
Adjusting the screen	4-19	GNSS antenna (for ProPILOT Assist 2.0) (if	
		so equipped)	4-38

NISSANCONNECT® OWNER'S MANUAL



For models with NissanConnect® System, refer to the digital NissanConnect® Owner's Manual using the QR code on this page (US only), or your printed NissanConnect® Owner's Manual (if so equipped). This manual includes the following information.

Available functions may vary depending on the models and specifications.

- Audio
- Hands-Free Phone
- Apple CarPlay®
- Android Auto™
- NissanConnect® Services powered by SiriusXM®

- Navigation system
- Voice Recognition System
- Amazon Alexa

4-2 Monitor, heater, air conditioner, audio and phone systems

SAFETY PRECAUTIONS



WARNING

- Do not adjust the display controls, heater and air conditioner controls or audio controls while driving so that full attention may be given to vehicle operation.
- If you noticed any foreign objects entering the system hardware, spilled liquid on the system, or noticed smoke or fumes coming out from the system, or any other unusual operation is observed, stop using the system immediately and contact the nearest knowledgeable repairer such as a NISSAN certified ARIYA dealer. Ignoring such conditions may lead to an accident, fire or electric shock.
- Do not disassemble or modify this system. If you do, it may lead to an accident, fire, or electric shock.

REARVIEW MONITOR (if so equipped)



CAUTION

Do not use the system when the electric vehicle system is not engaged for extended periods of time to prevent battery discharge.

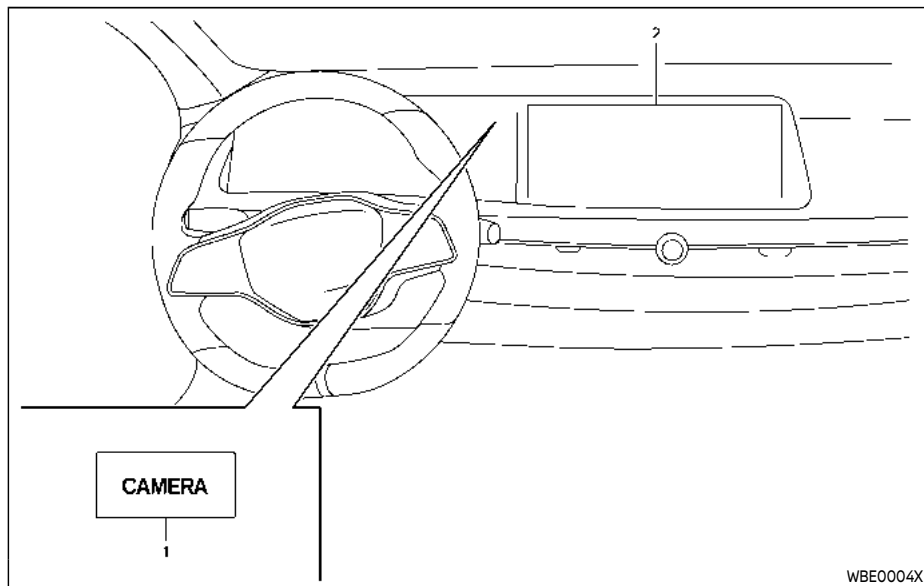

1. CAMERA button
2. Touch screen display



WARNING

- Failure to follow the warnings and instructions for proper use of the RearView Monitor could result in serious injury or death.

- **RearView Monitor is a convenience feature and is not a substitute for proper backing. Always turn and look out the windows, and check mirrors to be sure that it is safe to move before operating the vehicle. Always back up slowly.**
- **The system is designed as an aid to the driver in showing large stationary objects directly behind the vehicle, to help avoid damaging the vehicle.**
- **The distance guide line and the vehicle width line should be used as a reference only when the vehicle is on a level paved surface. The distance viewed on the monitor is for reference only and may be different than the actual distance between the vehicle and displayed objects.**



CAUTION

Do not scratch the camera lens when cleaning dirt or snow from the front of the camera.

cally shows a rear view of the vehicle when the shift lever is placed in the R (Reverse) position.

The radio can still be heard while the RearView Monitor is active.

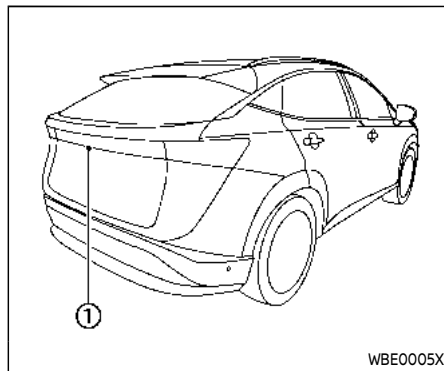

To display the rear view, the RearView Monitor system uses a camera ① located just above the vehicle's license plate.

REARVIEW MONITOR SYSTEM OPERATION

When the power switch is placed in the ON position, move the shift lever to the R (Reverse) position to operate the RearView Monitor.

The RearView Monitor system automati-

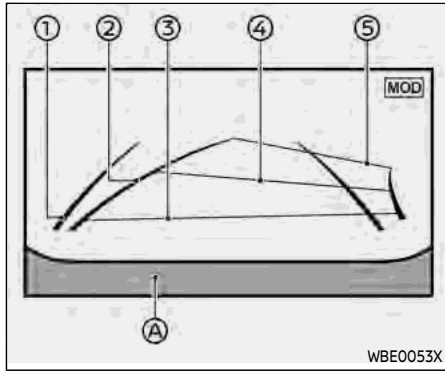

HOW TO READ THE DISPLAYED LINES

Guiding lines which indicate the vehicle width and distances to objects with reference to the bumper line **A** are displayed on the monitor.

Vehicle width guide lines **1**:

Indicate the vehicle width when backing up.

Predictive course lines **2**:

Indicate the predictive course when backing up. The predictive course lines will be displayed on the monitor when the shift lever is in the R (Reverse) position and if the steering wheel is turned.

The vehicle width guide lines and the width of the predictive course lines are wider than the actual width and course.

Distance guide lines:

Indicate distances from the vehicle body.

- Red line **3**: approximately 1.5 ft (0.5 m)
- Blue line **4**: approximately 3 ft (1 m)
- Blue line **5**: approximately 7 ft (2 m)

DIFFERENCE BETWEEN PREDICTIVE AND ACTUAL DISTANCES

The displayed guide lines and their locations on the ground are for approximate reference only. Objects on uphill or downhill surfaces or projecting objects will be actually located at distances different from those displayed in the monitor relative to the guide lines (refer to illustrations). When in doubt, turn around and view the objects as you are backing up, or park and exit the vehicle to view the positioning of objects behind the vehicle.

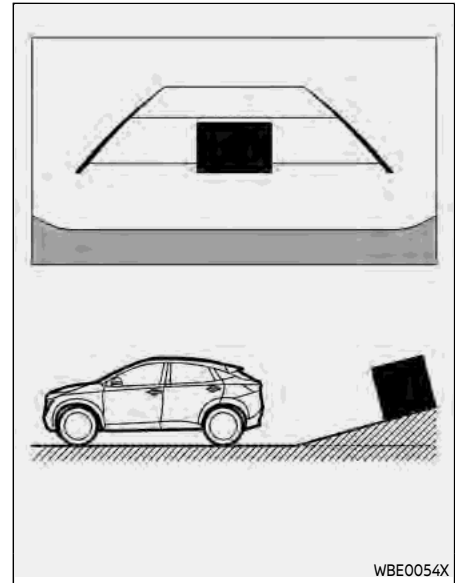

Backing up on a steep uphill

When backing up the vehicle up a hill, the distance guide lines and the vehicle width guide lines are shown closer than the actual distance. Note that any object on the hill is farther than it appears on the monitor.

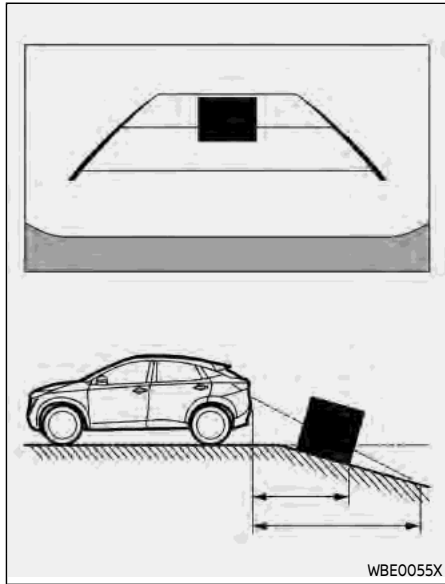

Backing up on a steep downhill

When backing up the vehicle down a hill, the distance guide lines and the vehicle width guide lines are shown farther than the actual distance. Note that any object on the hill is closer than it appears on the monitor.

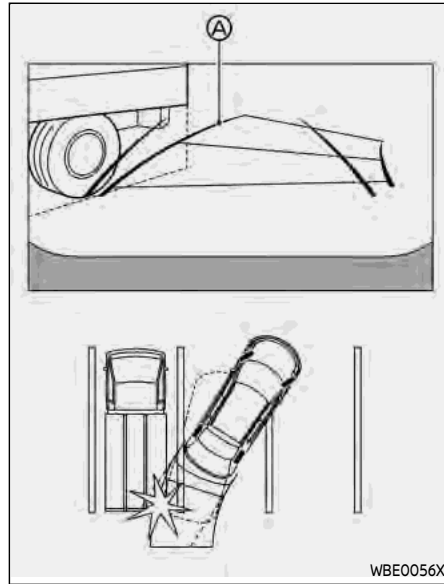

Backing up near a projecting object

The predictive course lines **A** do not touch the object in the display. However, the vehicle may hit the object if it projects over the actual backing up course.

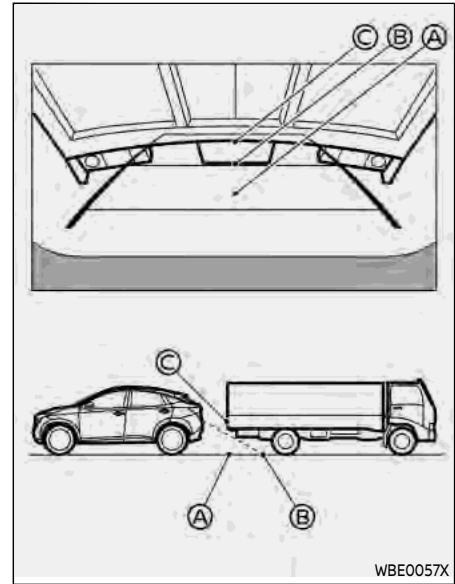

Backing up behind a projecting object

The position **C** is shown farther than the position **B** in the display. However, the position **C** is actually at the same distance as the position **A**. The vehicle may hit the object when backing up to the

position ④ if the object projects over the actual backing up course.

HOW TO PARK WITH PREDICTIVE COURSE LINES



WARNING

- If the tires are replaced with different sized tires, the predictive course lines may be displayed incorrectly.
- On a snow-covered or slippery road, there may be a difference between the predictive course line and the actual course line.
- If the 12-volt battery is disconnected or becomes discharged, the predictive course lines may be displayed incorrectly. If this occurs, please perform the following procedures:
 - Turn the steering wheel from lock to lock while the READY to drive indicator light is ON.
 - Drive the vehicle on a straight road for more than 5 minutes.
- When the steering wheel is turned with the power switch in the ON position, the predictive course lines may be displayed

incorrectly.

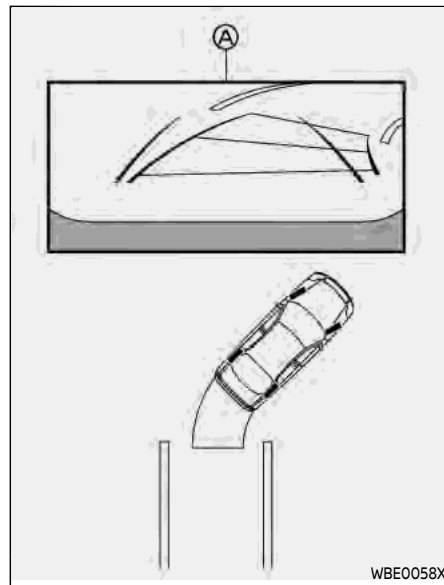

1. Visually check that the parking space is safe before parking your vehicle.
2. The rear view of the vehicle is displayed on the screen ④ when the shift lever is moved to the R (Reverse) position.

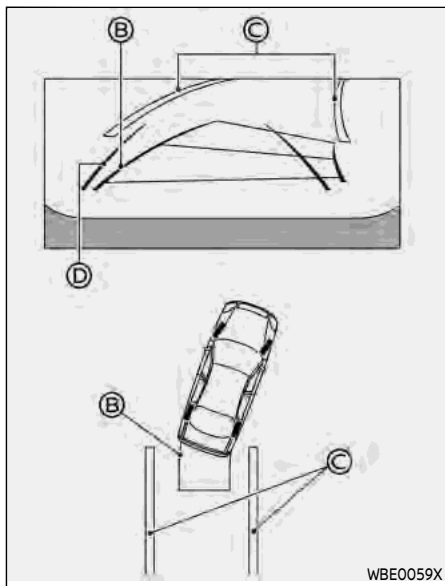

- When the vehicle is parked in the space completely, place the shift position to the P (Park) position and apply the parking brake.

- Slowly back up the vehicle adjusting the steering wheel so that the predictive course lines (B) enter the parking space (C).
- Maneuver the steering wheel to make the vehicle width guide lines (D) parallel to the parking space (C) while referring to the predictive course lines.

4-8 Monitor, heater, air conditioner, audio and phone systems

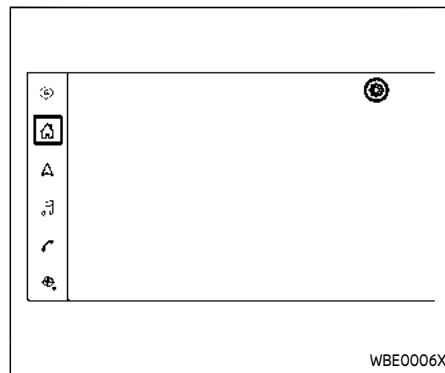

ADJUSTING THE SCREEN

- Touch "Home" key on the touch screen display.
- Touch "Settings" key.
- Touch the "Camera" key.
- Touch the "Display Settings" key.
- Touch the "+" or "-" key of the desired item on the touch screen display. You can change the brightness, contrast, tint, color, and black level.

NOTE:

Do not adjust any of the display settings of the RearView Monitor while the vehicle is moving. Make sure the parking brake is firmly applied.

HOW TO TURN ON AND OFF PREDICTIVE COURSE LINES

Pushing the CAMERA button while the shift lever is in the R (Reverse) position can turn on and off the predictive course lines.

REARVIEW MONITOR SYSTEM LIMITATIONS



WARNING

Listed below are the system limitations for RearView Monitor. Failure to operate the vehicle in accordance with these system limitations could result in serious injury or death.

- The system cannot completely eliminate blind spots and may not show every object.
- Underneath the bumper and the corner areas of the bumper cannot be viewed on the RearView Monitor because of its monitoring range limitation. The system will not show small objects below the bumper, and may not show objects close to the bumper or on the ground.

- **Objects viewed in the RearView Monitor differ from actual distance because a wide-angle lens is used.**
- **Objects in the RearView Monitor will appear visually opposite compared to when viewed in the rearview and outside mirrors.**
- **Use the displayed lines as a reference. The lines are highly affected by the number of occupants, energy level, vehicle position, road conditions and road grade.**
- **Make sure that the liftgate is securely closed when backing up.**
- **Do not put anything on the rear view camera. The rear view camera is installed above the license plate.**
- **When washing the vehicle with high-pressure water, be sure not to spray it around the camera. Otherwise, water may enter the camera unit causing water condensation on the lens, a malfunction, fire or an electric shock.**
- **Do not strike the camera. It is a precision instrument. Otherwise, it may malfunction or cause damage resulting in a fire or an**

electric shock.

The following are operating limitations and do not represent a system malfunction:

- When the temperature is extremely high or low, the screen may not clearly display objects.
- When strong light directly shines on the camera, objects may not be displayed clearly.
- Vertical lines may be seen in objects on the screen. This is due to strong reflected light from the bumper.
- The screen may flicker under fluorescent light.
- The colors of objects on the RearView Monitor may differ somewhat from the actual color of objects.
- Objects on the monitor may not be clear in a dark environment.
- There may be a delay when switching between views.
- If dirt, rain or snow accumulates on the camera, the RearView Monitor may not display objects clearly. Clean the camera.
- Do not use wax on the camera lens. Wipe off any wax with a clean cloth dampened with a diluted mild cleaning agent, then wipe with a dry cloth.

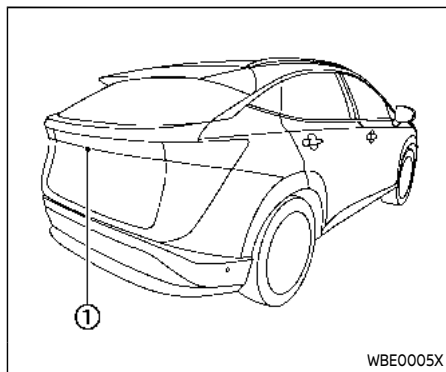

WBE0005X

diluted mild cleaning agent and then wiping it with a dry cloth.

SYSTEM MAINTENANCE



CAUTION

- Do not use alcohol, benzine or thinner to clean the camera. This will cause discoloration.
- Do not damage the camera as the monitor screen may be adversely affected.

If dirt, rain or snow accumulates on the camera ①, RearView Monitor may not display objects clearly. Clean the camera by wiping it with a cloth dampened with a

INTELLIGENT AROUND VIEW® MONITOR (if so equipped)

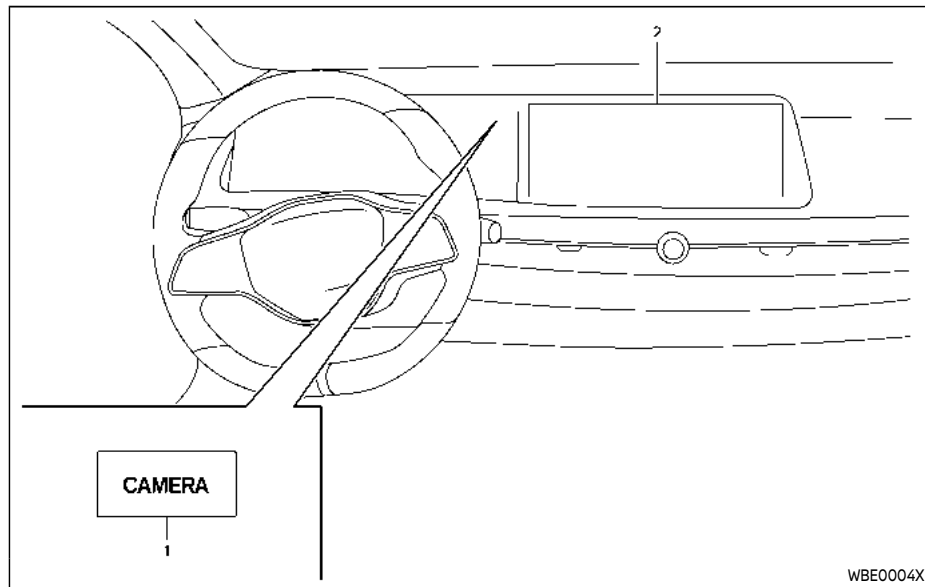

1. CAMERA button
2. Touch screen display

WARNING

- Failure to follow the warnings and instructions for the proper use of the Intelligent Around View® Monitor system could re-

sult in serious injury or death.

- The Intelligent Around View® Monitor is a convenience feature and is not a substitute for proper vehicle operation because it has areas where objects cannot be viewed. The four corners of the vehicle in particular, are areas where objects do not always appear in the bird's-eye, front, or rear views. Always check your surroundings to be sure that it is safe to move before operating the vehicle. Always operate the vehicle slowly.
- The driver is always responsible for safety during parking and other maneuvers.



CAUTION

Do not scratch the lens when cleaning dirt or snow from the front of the camera.

The Intelligent Around View® Monitor system is designed as an aid to the driver in situations such as slot parking or parallel parking.

The monitor displays various views of the

position of the vehicle in a split screen format. Not all views are available at all times.

Available views:

- Front view
A view of the front of the vehicle
- Rear view
A view of the rear of the vehicle
- Bird's-eye view
The surrounding view of the vehicle from above
- Front-side view
The view around and ahead of the front passenger's side wheel
- Front-wide view
A wider area view of the front view
- Rear-wide view
A wider area view of the rear view

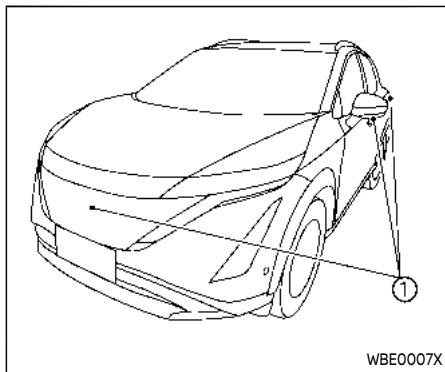

To display the multiple views, the Intelligent Around View® Monitor system uses cameras ① located on the front grille, on the vehicle's outside mirrors and one just above the vehicle's rear license plate.

**INTELLIGENT AROUND VIEW®
MONITOR SYSTEM OPERATION**

When the power switch is placed in the ON position, push the CAMERA button on the instrument panel or move the shift lever to the R (Reverse) position to operate the Intelligent Around View® Monitor.

The screen displayed on the Intelligent Around View® Monitor will automatically return to the previous screen 3 minutes

after the CAMERA button has been pushed with the shift lever in a position other than the R (Reverse) position.

Available views

⚠ WARNING

- The distance guide lines and the vehicle width guide lines should be used as a reference only when the vehicle is on a paved, level surface. The apparent distance viewed on the monitor may be different than the actual distance between the vehicle and displayed objects.
- Use the displayed lines and the bird's-eye view as a reference. The lines and the bird's-eye view are greatly affected by the number of occupants, vehicle position, road condition and road grade.
- If the tires are replaced with different sized tires, the predictive course lines and the bird's-eye view may be displayed incorrectly.
- When driving the vehicle up a hill, objects viewed in the monitor are farther than they appear. When

driving the vehicle down a hill, objects viewed in the monitor are closer than they appear.

- Objects in the rear view will appear visually opposite compared to when viewed in the rearview and outside mirrors.
- Use the mirrors or actually look to properly judge distances to other objects.
- The distance between objects viewed in the rear view differs from actual distance because a wide-angle lens is used.
- On a snow-covered or slippery road, there may be a difference between the predictive course line and the actual course line.
- The vehicle width and predictive course lines are wider than the actual width and course.

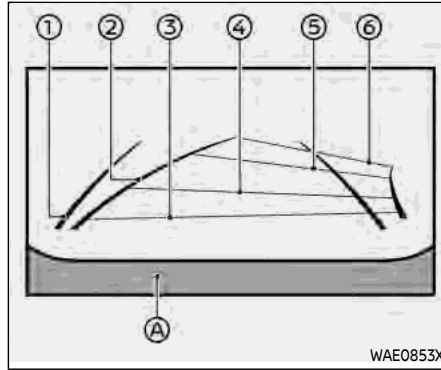

Front view

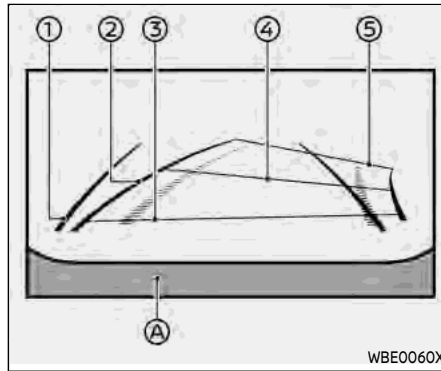

Rear view

Front and rear view:

Guiding lines that indicate the approximate vehicle width and distances to objects with reference to the vehicle body line (A), are displayed on the monitor.

Vehicle width guide lines ①:

Indicate the vehicle width.

Predictive course lines ②:

Indicate the predictive course when operating the vehicle. The predictive course lines will move depending on how much the steering wheel is turned.

Distance guide lines:

Indicate distances from the vehicle body.

- Red line ③: approximately 1.5 ft (0.5 m)
- Blue line ④: approximately 3 ft (1 m)
- Blue line ⑤: approximately 7 ft (2 m)
- Blue line ⑥: approximately 10 ft (3 m)

The front view will not be displayed when the vehicle speed is above 6 MPH (10 km/h).

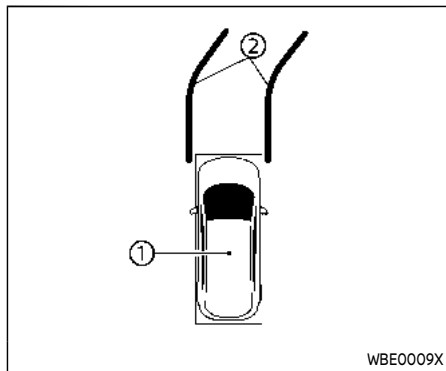

Bird's-eye view:

The bird's-eye view shows the overhead view of the vehicle which helps confirm the vehicle position and the predictive course to a parking space.

The vehicle icon ① shows the position of the vehicle. Note that the distance between objects viewed in the bird's-eye view differs from the actual distance.

The predictive course lines ② indicate the predicted course when operating the vehicle.

WARNING

- Objects in the bird's-eye view will appear farther than the actual distance.
- Tall objects, such as a curb or vehicle, may be misaligned or not displayed at the seam of the views.
- Objects that are above the camera cannot be displayed.
- The view for the bird's-eye view may be misaligned when the camera position alters.
- A line on the ground may be misaligned and is not seen as being straight at the seam of the views. The misalignment will increase as the line proceeds away from the vehicle.

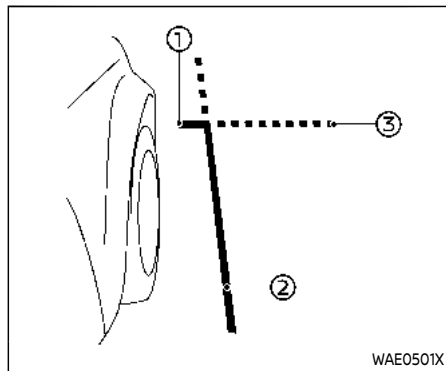

Front-side view:

Guiding lines:

Guiding lines that indicate the approximate width and the front end of the vehicle are displayed on the monitor.

The front-of-vehicle line ① shows the front part of the vehicle.

The side-of-vehicle line ② shows the vehicle width including the outside mirrors.

The extensions ③ of both the front ① and side ② lines are shown with a blue dotted line.



CAUTION

The turn signal light may look like the side-of-vehicle line. This is not a malfunction.

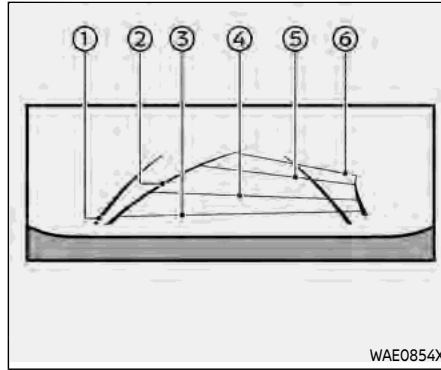

Front-wide view

WAE0854X

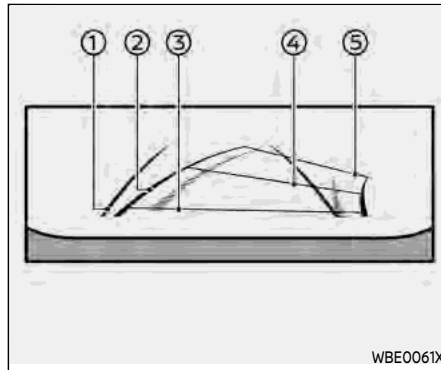

Rear-wide view

WBE0061X

Front-wide/rear-wide view:

While the front view/rear view shows a normal view on the split screens, the front-wide view/rear-wide view shows a wider area on the entire screen and allows checking of the blind corners on the right and left sides.

Vehicle width guide lines ①:

Indicate the approximate vehicle width.

Predictive course lines ②:

Indicate the predictive course when operating the vehicle. The predictive course lines will move depending on how much the steering wheel is turned.

Distance guide lines:

Indicate distances from the vehicle body.

- Red line ③: approx. 1.5 ft (0.5 m)
- Blue line ④: approx. 3 ft (1 m)
- Blue line ⑤: approx. 7 ft (2 m)
- Blue line ⑥: approx. 10 ft (3 m)

The front-wide view will not be displayed when the vehicle speed is above 6 MPH (10 km/h).

DIFFERENCE BETWEEN PREDICTIVE AND ACTUAL DISTANCES

The displayed guide lines and their locations on the ground are for approximate reference only. Objects on uphill or downhill surfaces or projecting objects will be actually located at distances different from those displayed in the monitor relative to the guide lines (refer to illustrations). When in doubt, turn around and view the objects as you are backing up, or park and exit the vehicle to view the positioning of objects behind the vehicle.

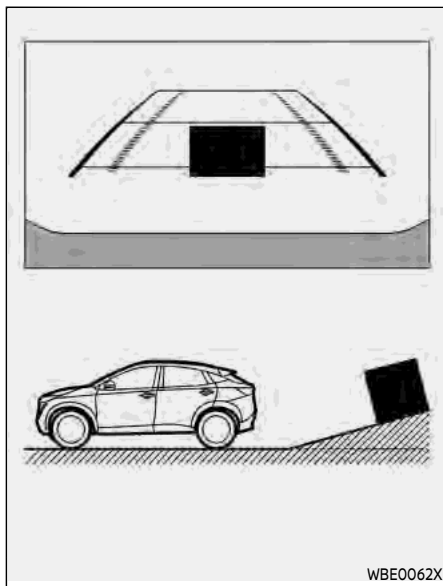

Backing up on a steep uphill

When backing up the vehicle up a hill, the distance guide lines and the vehicle width guide lines are shown closer than the actual distance. Note that any object on the hill is farther than it appears on the monitor.

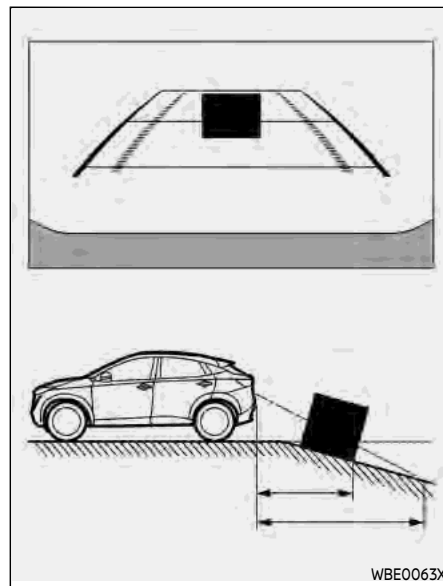

Backing up on a steep downhill

When backing up the vehicle down a hill, the distance guide lines and the vehicle width guide lines are shown farther than the actual distance. Note that any object on the hill is closer than it appears on the monitor.

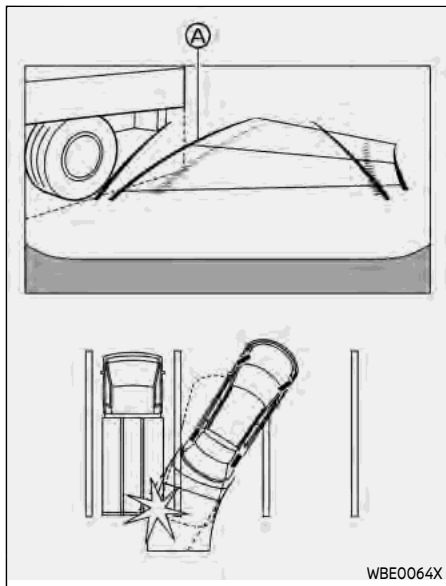

Backing up near a projecting object
 The predictive course lines (A) do not touch the object in the display. However, the vehicle may hit the object if it projects over the actual backing up course.

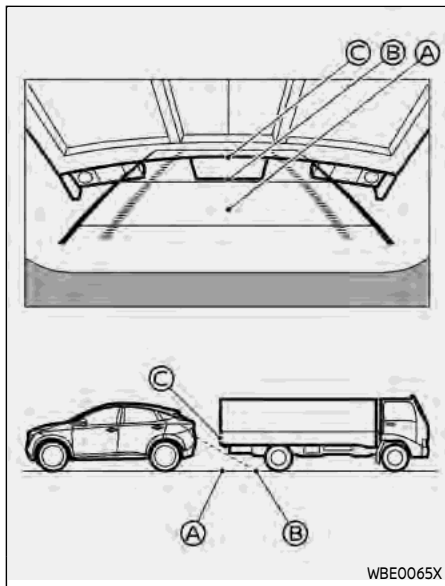

Backing up behind a projecting object
 The position (C) is shown farther than the position (B) in the display. However, the position (C) is actually at the same distance as the position (A). The vehicle may hit the object when backing up to the

position (A) if the object projects over the actual moving course.

HOW TO PARK WITH PREDICTIVE COURSE LINES

WARNING

- If the tires are replaced with different sized tires, the predictive course lines may be displayed incorrectly.
- On a snow-covered or slippery road, there may be a difference between the predictive course line and the actual course line.
- If the 12-volt battery is disconnected or becomes discharged, the predictive course lines may be displayed incorrectly. If this occurs, please perform the following procedures:
 - Turn the steering wheel from lock to lock while the READY to drive indicator light is ON.
 - Drive the vehicle on a straight road for more than 5 minutes.
- When the steering wheel is turned with the power switch in the ON position, the predictive course lines may be displayed

incorrectly.

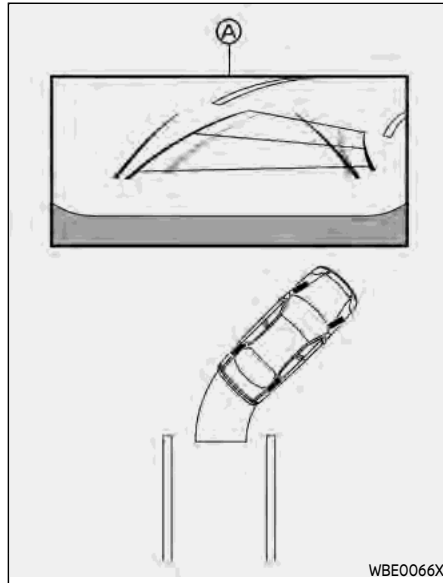

1. Visually check that the parking space is safe before parking your vehicle.
2. The rear view of the vehicle is displayed on the screen **A** when the shift lever is moved to the R (Reverse) position.

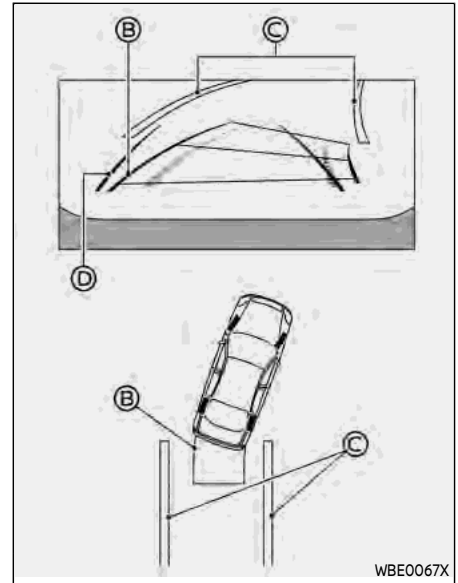

3. Slowly back up the vehicle adjusting the steering wheel so that the predictive course lines **B** enter the parking space **C**.
4. Maneuver the steering wheel to make the vehicle width guide lines **D** parallel to the parking space **C** while referring to the predictive course lines.

- When the vehicle is parked in the space completely, place the shift position in the P (Park) position and apply the parking brake.

HOW TO SWITCH THE DISPLAY

With the power switch placed in the ON position, push the CAMERA button or move the shift lever to the R (Reverse) position to operate the Intelligent Around View® Monitor.

The Intelligent Around View® Monitor displays different split screen views depending on the position of the shift lever. Push the CAMERA button to switch between the available views.

If the shift lever is in the R (Reverse) position, the available views are:

- Rear view/bird's-eye view split screen
- Rear view/front-side view split screen
- Rear-wide view

If the shift lever is out of the R (Reverse) position, the available views are:

- Front view/bird's-eye view split screen
- Front view/front-side view split screen
- Front-wide view

The display will switch from the Intelligent Around View® Monitor screen when:

- The shift lever is in the D (Drive) position and the vehicle speed increases above approximately 6 MPH

(10km/h).

- A different screen is selected.

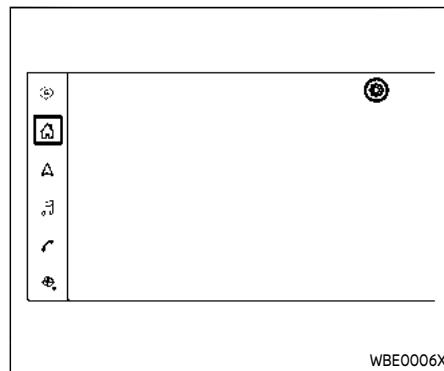

ADJUSTING THE SCREEN

1. Touch "🏠" key on the touch screen display.
2. Touch "⚙️" key.
3. Touch the "Camera" key.
4. Touch the "Display Settings" key.
5. Touch the "+" or "-" key of the desired item on the touch screen display. You can change the brightness, contrast, tint, color, and black level.

NOTE:

Do not adjust the display settings of the Intelligent Around View® Monitor while the vehicle is moving. Make sure the parking brake is firmly applied.

INTELLIGENT AROUND VIEW® MONITOR SYSTEM LIMITATIONS

WARNING

Listed below are the system limitations for Intelligent Around View® Monitor. Failure to operate the vehicle in accordance with these system limitations could result in serious injury or death.

- Do not use the Intelligent Around View® Monitor with the outside mirrors in the stored position, and make sure that the liftgate is securely closed when operating the vehicle using the Intelligent Around View® Monitor.
- The apparent distance between objects viewed on the Intelligent Around View® Monitor differs from the actual distance.
- The cameras are installed on the front grille, the outside mirrors and above the rear license plate. Do not put anything on the cameras.
- When washing the vehicle with high pressure water, be sure not to spray it around the cameras.

Otherwise, water may enter the camera unit causing water condensation on the lens, a malfunction, fire or an electric shock.

- Do not strike the cameras. They are precision instruments. Doing so could cause a malfunction or cause damage resulting in a fire or an electric shock.

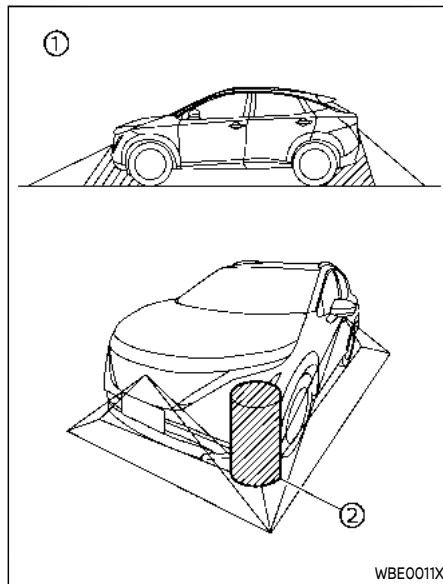

There are some areas where the system will not show objects and the system does not warn of moving objects. When in the front or the rear view display, an object below the bumper or on the ground may not be viewed ①. When in the bird's-eye view, a tall object near the seam ② of the camera viewing areas will

not appear in the monitor.

The following are operating limitations and do not represent a system malfunction:

- There may be a delay when switching between views.
- When the temperature is extremely high or low, the screen may not display objects clearly.
- When strong light directly shines on the camera, objects may not be displayed clearly.
- The screen may flicker under fluorescent light.
- The colors of objects on the Intelligent Around View® Monitor may differ somewhat from the actual color of objects.
- Objects on the Intelligent Around View® Monitor may not be clear and the color of the object may differ in a dark environment.
- There may be differences in sharpness between each camera view of the bird's-eye view.
- Do not use wax on the camera lens. Wipe off any wax with a clean cloth that has been dampened with a diluted mild cleaning agent, then wipe with a dry cloth.

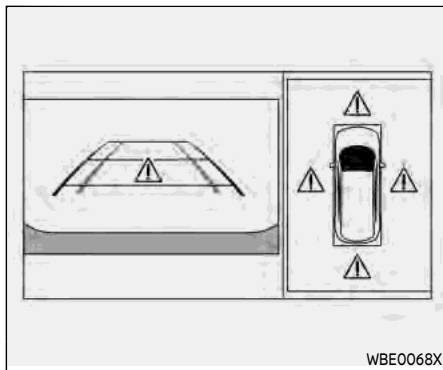

System temporarily unavailable

When the "▲" icon is displayed on the screen, there will be abnormal conditions in the Intelligent Around View® Monitor. This will not hinder normal driving operation but the system should be inspected. It is recommended you visit a NISSAN certified ARIYA dealer.

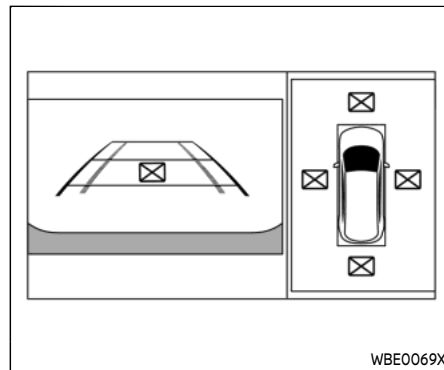

When the "⊠" icon is displayed on the screen, the camera image may be receiving temporary electronic disturbances from surrounding devices. This will not hinder normal driving operation but the system should be inspected. It is recommended you visit a NISSAN certified ARIYA dealer.

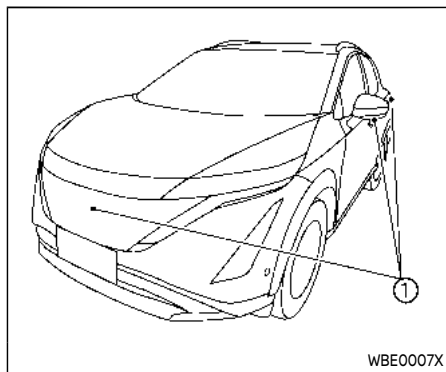

cloth dampened with a diluted mild cleaning agent and then wiping with a dry cloth.

SYSTEM MAINTENANCE



CAUTION

- Do not use alcohol, benzine or thinner to clean the camera. This will cause discoloration.
- Do not damage the camera as the monitor screen may be adversely affected.

If dirt, rain or snow accumulates on any of the cameras ①, the Intelligent Around View® Monitor may not display objects clearly. Clean the camera by wiping with a

MOVING OBJECT DETECTION (MOD) (if so equipped)

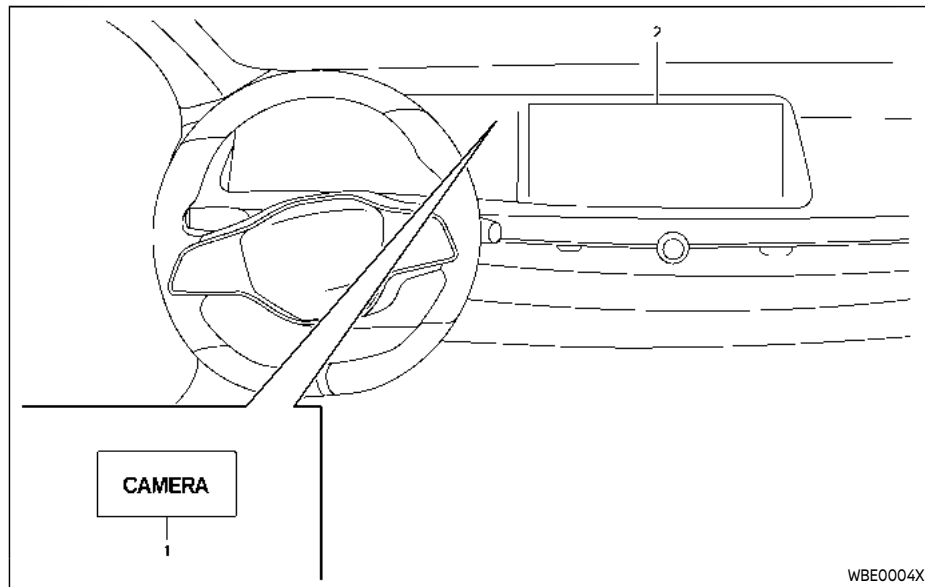

1. CAMERA button
2. Touch screen display



WARNING

- Failure to follow the warnings and instructions for proper use of the Moving Object Detection system could result in serious

injury or death.

- The MOD system is not a substitute for proper vehicle operation and is not designed to prevent contact with objects surrounding the vehicle. When maneuvering, always use the outside mirror and rearview mirror and turn and check the surroundings to ensure it is safe to maneuver.
- The system is deactivated at speeds above 5 MPH (8km/h). It is reactivated at lower speeds.
- The MOD system is not designed to detect the surrounding stationary objects.

The MOD system can inform the driver of moving objects near the vehicle when driving out of garages, maneuvering in parking lots and in other such instances.

The MOD system detects moving objects by using image processing technology on the image shown in the display.

MOD SYSTEM OPERATION

The MOD system will turn on automatically under the following conditions:

- When the shift lever is in the R (Reverse) position.
- When the CAMERA button is pushed to activate the Intelligent Around View® Monitor system on the display.
- When vehicle speed decreases below approximately 5 MPH (8km/h).

The MOD system operates in the following conditions when the camera view is displayed:

- When the shift lever is in the P (Park) or N (Neutral) position and the vehicle is stopped, the MOD system detects the moving objects in the bird's-eye view. The MOD system will not operate if either door is opened. If outside mirrors are folded, MOD may not operate properly.
- When the shift lever is in the D (Drive) position, and the vehicle speed is below approximately 5 MPH (8km/h), the MOD system detects moving objects in the front view or front-wide view.
- When the shift lever is in the R (Reverse) position and the vehicle speed is below approximately 5 MPH (8km/h), the MOD system detects

moving objects in the rear view or rear-wide view. The MOD system will not operate if the liftgate is open.

The MOD system does not detect moving objects in the front-side view. The MOD icon is not displayed on the screen when in this view.

When the MOD system detects a moving object near the vehicle, the yellow frame will be displayed on the view where the object is detected and a chime will sound once. While the MOD system continues to detect moving objects, the yellow frame continues to be displayed.

NOTE:

While the RCTA chime is beeping, the MOD system does not chime.

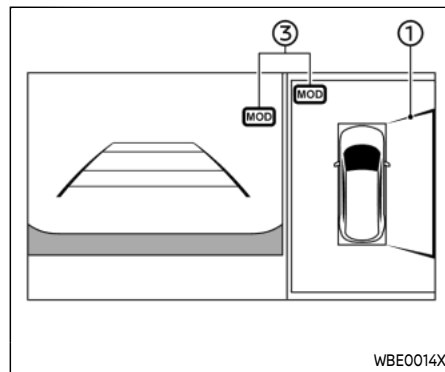

Front and bird's-eye views

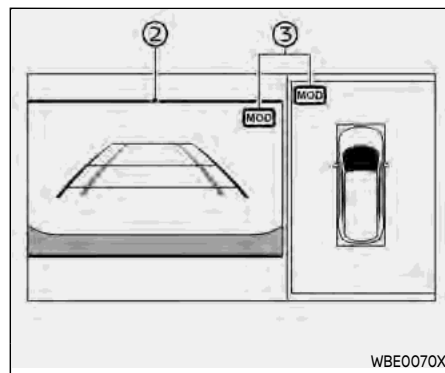

Rear and bird's-eye views

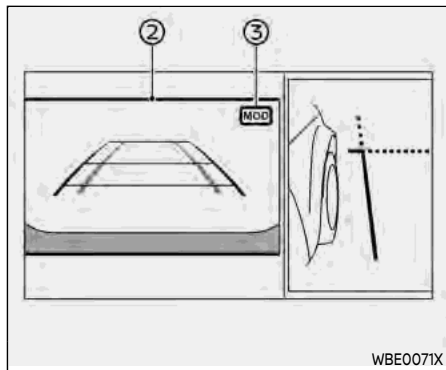

Rear and front-side views

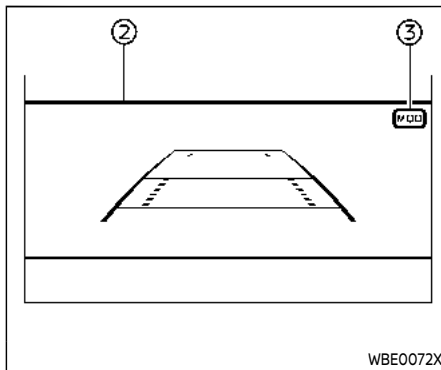

Rear-wide view

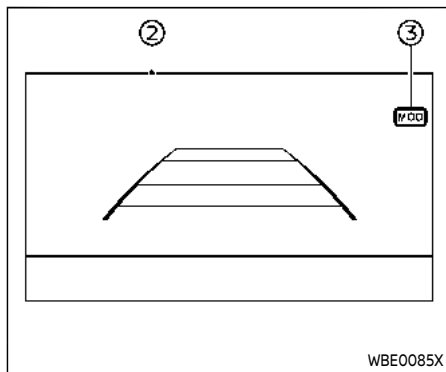

Front-wide view (example)

In the bird's-eye view, the yellow frame ① is displayed on each camera image (front, rear, right, left) depending on where moving objects are detected.

The yellow lines ② are displayed on the front view, rear view, front-wide view and rear-wide view.

A green MOD icon ③ is displayed in the view where the MOD system is operative. A gray MOD icon ③ is displayed in the view where the MOD system is not operative.

If the MOD system is turned off, the MOD icon ③ is not displayed.

TURNING MOD ON AND OFF

The MOD system can be turned on and off using the vehicle information display. (See "Driver Assistance" (P.2-25).)

MOD SYSTEM LIMITATIONS



WARNING

Listed below are the system limitations for MOD. Failure to operate the vehicle in accordance with these system limitations could result in serious injury or death.

- Do not use the MOD system when towing a trailer (AWD models). The system may not function properly.
- Excessive noise (for example, audio system volume or open vehicle window) will interfere with the chime sound, and it may not be heard.
- The MOD system performance will be limited according to environmental conditions and surrounding objects such as:
 - When there is low contrast between background and the moving objects.

- When there is blinking source of light.
 - When strong light such as another vehicle's headlight or sunlight is present.
 - When camera orientation is not in its usual position, such as when the outside mirror is folded.
 - When there is dirt, water drops or snow on the camera lens.
 - When the position of the moving objects in the display is not changed.
- The MOD system might detect flowing water droplets on the camera lens, white smoke from the muffler, moving shadows, etc.
 - The MOD system may not function properly depending on the speed, direction, distance or shape of the moving objects.
 - If your vehicle sustains damage to the parts where the camera is installed, leaving it misaligned or bent, the sensing zone may be altered and the MOD system may not detect objects properly.

- When the temperature is extremely high or low, the screen may not display objects clearly. This is not a malfunction.

NOTE:

The green MOD icon will change to orange if one of the following has occurred.

- When the system is malfunctioning.
- When the component temperature reaches a high level.
- When the rear view camera has detected a blockage.

If the icon light continues to illuminate in orange, have the MOD system checked. It is recommended that you visit a NISSAN certified ARIYA dealer for this service.

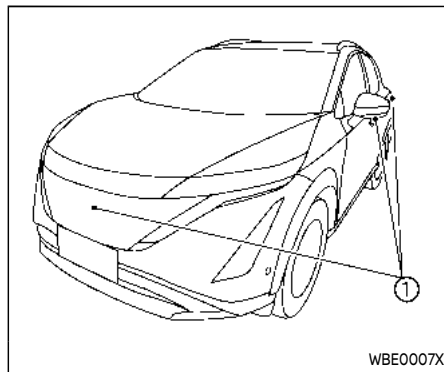

WBE0007X

SYSTEM MAINTENANCE



CAUTION

- Do not use alcohol, benzine or thinner to clean the camera. This will cause discoloration.
- Do not damage the camera as the monitor screen may be adversely affected.

If dirt, rain or snow accumulates on any of the cameras ①, the MOD system may not operate properly. Clean the camera by wiping with a cloth dampened with a

VENTILATORS

diluted mild cleaning agent and then wiping with a dry cloth.

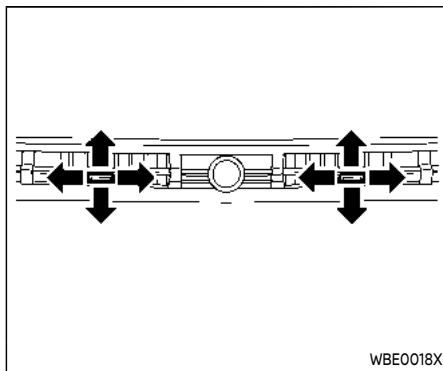

CENTER VENTILATORS

Open or close the vents, and adjust the air flow direction of the ventilators by moving the center knob as illustrated.

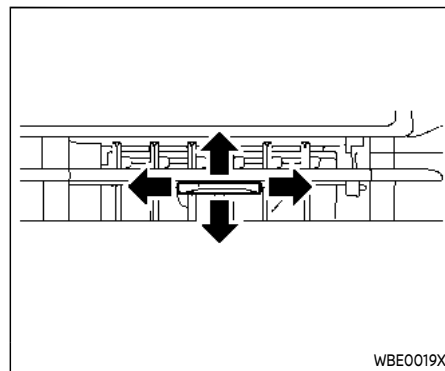

Right side

SIDE VENTILATORS

Open or close the vents, and adjust the air flow direction of the ventilators by moving the center knob as illustrated.

HEATER AND AIR CONDITIONER

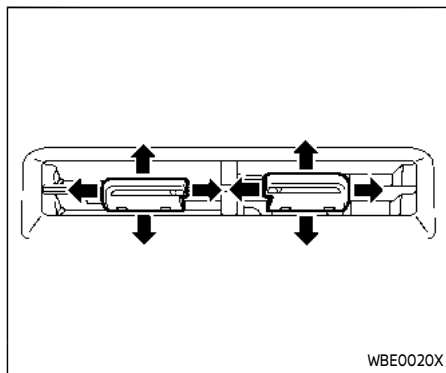

REAR VENTILATORS

Open or close the vents, and adjust the air flow direction of the ventilators by moving the center knob as illustrated.

WARNING

- The air conditioning cooling function operates only when the power switch is in the ON position or when the READY to drive indicator light is illuminated.
- Never leave children or adults who would normally require the support of others alone in the vehicle. Pets should not be left alone either. They could unknowingly activate switches or controls and inadvertently become involved in a serious accident and injure themselves. On hot, sunny days, temperatures in a closed vehicle could quickly become high enough to cause severe or possibly fatal injuries to people or animals.
- Do not use the recirculation mode for long periods as it may cause the interior air to become stale and the windows to fog up.
- Do not adjust the heating and air conditioning controls while driving so that full attention may be given to vehicle operation.

NOTE:

- Odors from inside and outside the vehicle can build up in the air conditioner unit. Odor can enter the passenger compartment through the ventilators.
- When parking, set the heater and air conditioner controls to turn off air recirculation to allow fresh air into the passenger compartment. This should help reduce odors inside the vehicle.

The heater and air conditioner operate when the READY to drive indicator light is illuminated. However, while charging, the heater and air conditioner can be used when the power switch is in the ON position.

The fan, heater and air conditioning can be turned on automatically using the timer function.

These functions operate in the following conditions.

Power switch position	OFF	Auto ACC	ON	READY to drive
Fan	-	-	X	X
Heater and air conditioner	-	-	X	X
Timer (Climate Ctrl. Timer)	X	X	-	-
Remote climate control	X	X	-	-

X: Available

NOTE:

- **A series of operation sounds may be heard immediately after heater and air conditioner system ON/OFF operation. This is not a malfunction.**
- **Condensation forms inside the heater and air conditioner system unit when the heater and air conditioner system is running, and is safely discharged underneath your vehicle. Traces of water on the ground are therefore normal.**
- **Compressor and motor fan may suddenly start to operate during charging operation. This is not a malfunction.**

AUTOMATIC AIR CONDITIONER

You can use either buttons on the instrument panel or keys on the climate control screen to control the automatic air conditioner.

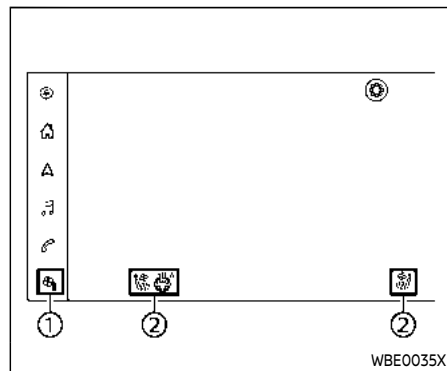

Example

To display the climate control screen, touch the "⏻" key ① on the touch screen display.

You can also control some air conditioner settings by touching "🌬️" or "🌡️" key ② (example) while displaying other than climate control screen.

When the air conditioner is on, the temperature is shown next to the key ②.

You can also operate the air conditioner by touching the temperature area.

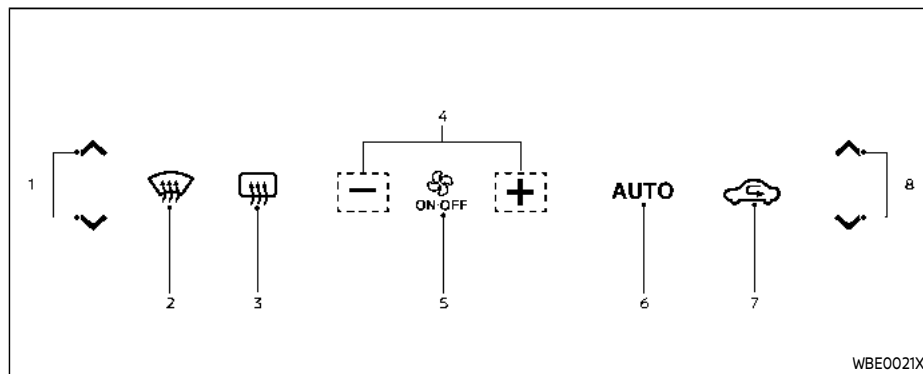

WBE0021X

Buttons on the instrument panel

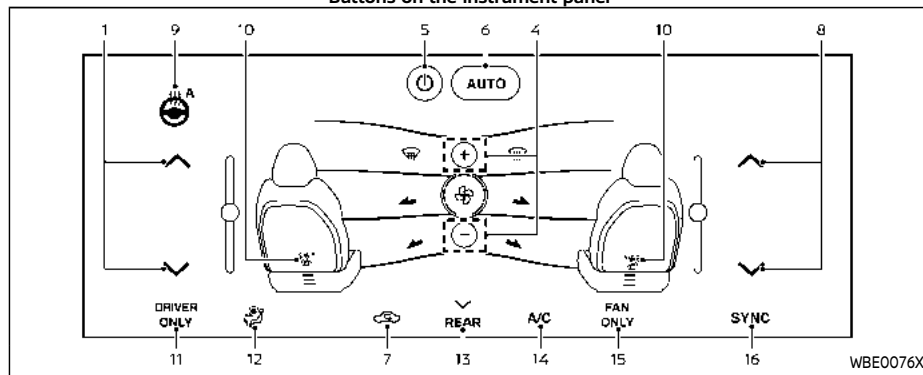

WBE0076X

Climate control screen

1. Temperature control button/temperature control key (driver's side)
2. (front defroster) button
3. (rear window defroster) button
(See "Rear window and outside mirror defroster switch" (P.2-60).)
4. Fan speed control buttons/fan speed control keys
5. ON-OFF button/key
6. AUTO (automatic) button/"AUTO" (automatic) key
7. Air intake control button/key
8. Temperature control button/temperature control key (passenger's side)
9. Heated steering wheel key (if so equipped)
(See "Heated steering wheel" (P.2-70).)
10. Front seat control key (if so equipped)
(See "Climate controlled seats" (P.2-73) or "Heated seats" (P.2-70).)
11. "DRIVER ONLY" key
12. Air flow control key
13. "REAR" key (if so equipped)
(See "Heated seats" (P.2-70).)
14. "A/C" (air conditioner) key
15. "FAN ONLY" key
16. "SYNC" (synchronize) key

Automatic operation

Heating and dehumidified cooling (AUTO):

This mode may be used all year round as the system automatically works to keep a constant temperature. Air flow distribution, fan speed are also controlled automatically.

Depending on the settings, heated seats (if so equipped), climate controlled seats (if so equipped) and heated steering wheel (if so equipped) can also be controlled. (See "Air conditioner settings" (P.4-33).)

1. Use the AUTO button or key to turn on the heater and air conditioner in automatic mode. (The color of the button and key will turn orange.)
2. Adjust the temperature by using the temperature control button or key, or sliding bar on the corresponding side.
 - You can individually set temperatures for the driver's side and front passenger's side. To set both temperatures at the same time, touch the "SYNC" key. (The color of the key will turn orange.)

NOTE:

- **A visible mist may be seen coming from the ventilators in hot, humid conditions as the air is cooled rapidly.**

pidly. This does not indicate a malfunction.

- **To save power, use the automatic mode or the ventilation mode. While the AUTO button and key turning orange, electric power consumption of the air conditioner system can have a better efficiency compared to the amount consumed with the AUTO button and key turning white. While ventilation mode is activated, outside air is drawn into the cabin using the fans with no heating or cooling applied. This significantly reduces energy consumption.**

Heating (A/C OFF):

The air conditioner does not activate in this mode. Use this mode when you only need to heat.

1. Use the AUTO button or key to turn on the heater and air conditioner in automatic mode. (The color of the button and key will turn orange.)
2. Touch the "A/C" key. (The color of the key will turn white.)
3. Use the temperature control button or key on the corresponding side to set the desired temperature.
 - You can individually set temperatures for the driver's side and front passenger's side when the color of



the "SYNC" key is white.

- The temperature of the passenger compartment will be maintained automatically. Air flow distribution and fan speed are also controlled automatically.

NOTE:

It is not recommended to use this mode if windows fog up.

Dehumidified defrosting or defogging:

1. Push the  button. (The color of the button will turn orange.)
2. Use the temperature control button or key on the corresponding side to set the desired temperature.
 - To quickly remove ice from the outside of the windows, use the fan speed control buttons or keys to set the fan speed to maximum.
 - As soon as possible after the windshield is clean, use the AUTO button or key to return to the automatic mode.
 - When the  button is pushed, the air conditioner will automatically be turned on at outside temperatures more than slightly above freezing. The air recirculation mode automatically turns off, allowing outside air to be drawn into the passenger compartment to further improve

the defogging performance.

Manual operation

Fan speed control:

Use the fan speed control buttons or keys to manually control the fan speed.

Air intake control:

The air intake control mode will change each time the air intake control button or key is pushed or touched.

- When the air recirculates inside the vehicle, the color of the air intake control button and key are orange.
- When the air flow is drawn from outside the vehicle, the color of the air intake control button and key are white.
- When the "AUTO" icon is displayed in the climate control screen, the air intake will be controlled automatically.
- When the power switch is placed in the ON position, the air conditioning system may change to air recirculation mode automatically to increase cooling efficiency.

Air flow control:

Touching the air flow control key manually controls air flow and selects the air outlet:

- ☞ — Air flows mainly from center and side ventilators.
- ☞ — Air flows mainly from center and side ventilators and foot outlets.
- ☞ — Air flows mainly from the foot outlet and partly from the defroster.
- ☞ — Air flows mainly from the defroster and foot outlets.

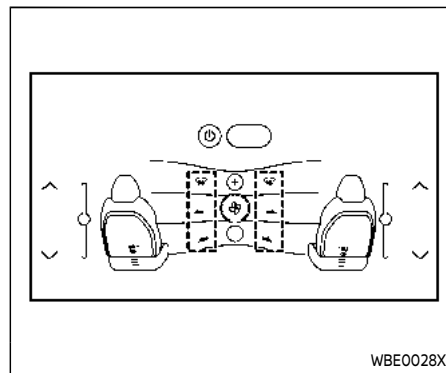

On the climate control screen, the status of air flow for each position can be checked.

You can turn on and off air flow individually by touching the desired position.

The amount of wind can change by swiping the display.

When adjusting the temperature, the color of display showing the amount of wind will change. These colors are not indicate the temperature of wind but the set temperature.

Ventilation:

Touch the "FAN ONLY" key to turn on the ventilation mode. (The color of the key will

turn orange.)

NOTE:

- **The ventilation mode requires a lower power consumption, so driving range will increase.**
- **In ventilation mode, temperature is not indicated on the climate control screen.**

DRIVER ONLY mode:

Touch the "DRIVER ONLY" key to turn on the DRIVER ONLY mode. (The color of the key will turn orange.) The air flows mainly from the driver's side in the DRIVER ONLY mode.

NOTE:

The DRIVER ONLY mode requires a lower power consumption, so driving range will increase.

Synchronize temperature settings:

Touch the "SYNC" key to turn on the SYNC mode. (The color of the key will turn orange.)

When the SYNC mode is active, the driver's side temperature control button or key will control the driver's and front passenger's side temperatures.

To exit the SYNC mode, change the passenger's side temperature on the front passenger's side. (The color of the "SYNC" key will turn white.)

To turn the system off

Push or touch the ON-OFF button/key. The color of the button and key will turn white.

Humidity control

This system controls dryness by detecting humidity inside a vehicle and temperature of window surface with sensors in the multi-sensing front camera unit. The system start defogging automatically when it detects windows fog up.

The humidity control system may not activate when an outside temperature drops to near 32°F (0° C).

When the color of the "A/C" key is white, defrosting feature may not activate. Take the one of the following actions to activate defrosting feature.

- Use the AUTO button or key.
- Push the  button.
- Touch the "A/C" key.

AIR CONDITIONER SETTINGS

Touch the  key on the climate control screen to change the air conditioner settings.

Available settings (if so equipped):

- **Driver's Seat Sensitivity**
The temperature control sensitivity level of the driver's side of the climate

controlled seat (if so equipped) or the heated seat (if so equipped) for automatic control mode can be changed from 1 (low) to 5 (high).

See "Climate controlled seats" (P.2-73) and "Heated seats" (P.2-70).

While the setting is "OFF", the function will not be activated when using the automatic air conditioner.

- **Passenger's Seat Sensitivity**

The temperature control sensitivity level of the passenger's side of the climate controlled seat (if so equipped) or the heated seat (if so equipped) for automatic control mode can be changed from 1 (low) to 5 (high).

See "Climate controlled seats" (P.2-73) and "Heated seats" (P.2-70).

While the setting is "OFF", the function will not be activated when using the automatic air conditioner.

- **Heated Steering Wheel Sensitivity**



The temperature control sensitivity level of the heated steering wheel for automatic control mode can be changed from 1 (low) to 5 (high).

See "Heated steering wheel" (P.2-70).

While the setting is "OFF", the function will not be activated when using the automatic air conditioner.

ADJUSTING BUTTON SENSITIVITY

The sensitivity of the buttons on the instrument panel can be changed.

1. Start the EV system.
2. Push and hold the AUTO button for approximately 10 second within 15 seconds after the EV system starts. The air intake control, AUTO, , or  button will blink in orange.

The number of buttons blinking show the setting of sensitivity.

- Four buttons are blinking: high (easy to react)
 - One button is blinking: low (hard to react)
3. Push the driver's side temperature control button to adjust the sensitivity.
 4. The sensitivity will be set 10 seconds after stopping using the buttons.

OPERATING TIPS

- Using the automatic mode will help reduce the power consumption of the air conditioner.
- When the AUTO button or key is used, the color of the button and key will turn orange. The color of the "A/C" key also turns orange.

- When the fan speed control button or key, or air flow control keys are used while the AUTO mode is turned on, the corresponding function will change to manual operation mode. At this time, functions other than the operated function will keep the automatic mode.
- Power consumption of the heater and air conditioner system varies depending on the outside temperature and the temperature set for the heater and air conditioner system. Power consumption increases if the interior temperature is cooled down too much in summer or if it is warmed up too much in winter. This will result in a reduced driving range.
- The Climate Ctrl. Timer or the remote climate control (if so equipped) may fog up windows depending on the set temperature or outside temperature.
- When the Climate Ctrl. Timer or the remote climate control is operating, the seat heater and the steering wheel heater may turn on automatically.
- Even when the air conditioner is off, the air conditioner may turn on automatically to cool the Li-ion battery. In this case, a noise from compressor and cooling fan may be heard. This is not a malfunction.
- When the Climate Ctrl. Timer or the remote climate control is operating, a noise from compressor and cooling fan may be heard. This is not a malfunction. When the temperature control system of the Li-ion battery uses power from the Li-ion battery, the air conditioner turns on automatically. This is not a malfunction.

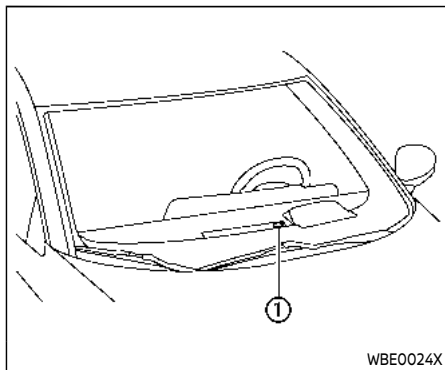

Sensors:

The sensors ① and ② located on the instrument panel, help maintain a constant temperature. Do not put anything on or around the sensors.

CLIMATE CTRL. TIMER

This function pre-heats or pre-cools the passenger compartment of the vehicle to the temperature before driving. This helps reduce power consumption from the Li-ion battery while driving.

The Climate Ctrl. Timer operates the heater and air conditioner system using power from the charger or the Li-ion battery.

The Climate Ctrl. Timer function allows three timer settings.

Once the Climate Ctrl. Timer is set, it will complete air conditioning by the time that is set. It is not necessary to set the Climate Ctrl. Timer everyday.

The Climate Ctrl. Timer function will not operate when the remaining capacity of the Li-ion battery is low.

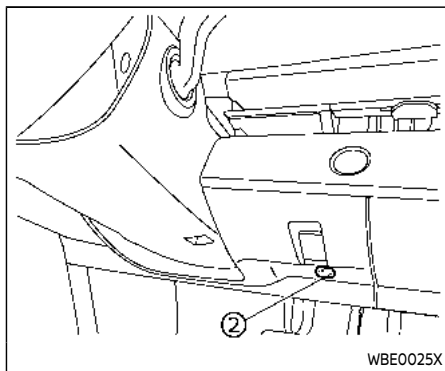

low if the system automatically stops. Do not leave children or adults who would normally require the support of others alone in your vehicle. Pets should not be left alone either. On hot, sunny days, temperatures in a closed vehicle could quickly become high enough to cause severe or possibly fatal injuries to people or animals. Also on cold days, temperature in a vehicle could become low enough to cause severe or possible fatal injuries to people or animals.

How to set Climate Ctrl. Timer

The Climate Ctrl. Timer settings can be changed with the touch screen display.



WARNING

Even if the Climate Ctrl. Timer is set, the temperature in the passenger compartment may become high or

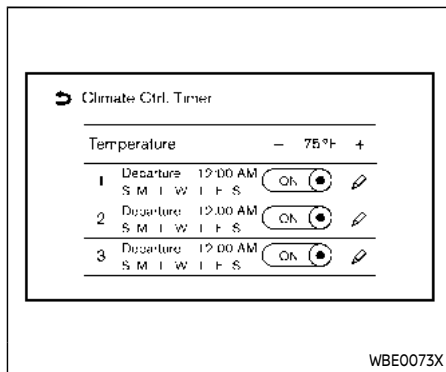

- key

Touch to display the Climate Ctrl. Timer setting screen. Set preferred time and day of the week for Climate Ctrl. Timer activation.

4. After completing the settings, place the power switch in the OFF position, and then connect the charge connector to the vehicle.

1. Touch the "" key on the touch screen display.
2. Touch the "All Apps" key and then touch "EV" key.
3. Touch the "Climate Ctrl. Timer" key. Climate Ctrl. Timer screen is displayed.

Available setting items:

- Temperature
Touch the "-"/"+" key to adjust the temperature.
- Timer settings
Touch to turn on/off the timer. The indicator light will turn on when the timer setting is turned on.

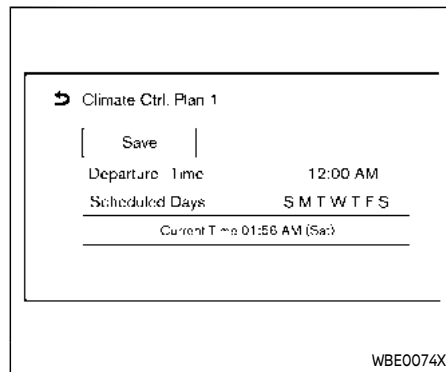

Climate Ctrl. Timer setting screen:

1. Touch "Departure Time" key to set the departure time.
2. Touch "Scheduled Days" key and select the days of the week you wish to activate the Climate Ctrl. Timer.
3. Touch "Save" key to save the setting.

NOTE:

The Climate Ctrl. Timer operates repeatedly once it is turned on.

Operating tips for using Climate Ctrl. Timer:

- The Climate Ctrl. Timer will only start when the power switch is in the OFF or Auto ACC position.

- To turn off the Climate Ctrl. Timer function, touch "ON" key until the indicator light turns off. The start and stop time settings will not be deleted even if the Climate Ctrl. Timer function is turned off.
- If the Climate Ctrl. Timer starts operating while the vehicle is being charged, the time required for charging will be longer.
- Operating the Climate Ctrl. Timer in an environment where the temperature is low may decrease the rate of battery charge.
- Timer setting can also be changed while Climate Ctrl. Timer is operated. When the power switch is in the OFF position, the heater and air conditioner system starts or enters waiting mode depending on the new timer settings.
- When the difference in temperature between the Climate Ctrl. Timer setting temperature and the temperature outside the vehicle is large, the temperature inside the vehicle may not be maintained at the setting temperature.
- The temperature in the passenger compartment may not be comfortable if entering the vehicle too soon before or too long after the scheduled

time of departure.

- The heater and air conditioner system operation is limited to the capacity of the electric power when the charge connector is connected to the vehicle. Therefore, the temperature may not reach the set temperature due to limitations in heater and air conditioner system performance, if ambient temperature is excessively high or low.
- The Climate Ctrl. Timer operates the heater and air conditioner system function so that a comfortable temperature is provided in the passenger compartment at the scheduled time of departure. The heater and air conditioner system is set to stop at the scheduled time of departure.
- Depending on the facilities of charging station, there may be time when it is not available for charging. Confirm the availability of the charging facility before setting the Climate Ctrl. Timer. Be sure that the power switch of the charger is turned on when setting the Climate Ctrl. Timer.
- When the power switch is placed in the OFF position after changing the setting, the new setting will be applied.

SERVICING AIR CONDITIONER



WARNING

The air conditioner system contains refrigerant under high pressure. To avoid personal injury, any air conditioner service should be done only by an experienced technician with the proper equipment.

The air conditioner system in your vehicle is charged with a refrigerant designed with the environment in mind.

This refrigerant will not harm the earth's ozone layer. However, it may contribute in a small part to global warming.

Special charging equipment and lubricant are required when servicing your vehicle's air conditioner. Using improper refrigerants or lubricants will cause severe damage to the air conditioner system. (See "Air conditioning system refrigerant and lubricant recommendations" (P.10-3).)

A NISSAN certified ARIYA dealer will be able to service your environmentally friendly air conditioner system.

In-cabin microfilter

The air conditioner filter system is equipped with an in-cabin microfilter. To make sure the air conditioner heats, defogs, and ventilates efficiently, replace the filter according to the specified maintenance intervals listed in the "9. Maintenance and schedules" section. It is recommended to visit a NISSAN certified ARIYA dealer to replace the filter.

The filter should be replaced if the air flow decreases significantly or if windows fog up easily when operating the heater or air conditioner.

RADIO ANTENNA

The antenna is located on the rear part of the vehicle roof. (See "Exterior rear" (P.O-4).)



CAUTION

- **A build up of ice on the antenna can affect radio performance. Remove the ice to restore radio reception.**
- **When removing snow from the roof, do not apply strong force to the antenna. That may cause broken antenna and roof panel dent.**
- **When using a high pressure car wash, keep the high pressure nozzle away from the antenna. The seal may be deformed or damaged.**
- **The radio performance may be affected if cargo carried on the roof blocks the radio signal. If possible, do not put cargo near the antenna.**

GNSS ANTENNA (for ProPILOT Assist 2.0) (if so equipped)

Two antennas are located on the rear part of the vehicle roof. (See "Exterior rear" (P.O-4).)



CAUTION

- **A build up of ice on the antenna can affect GNSS performance. Remove the ice to restore GNSS reception.**
- **When removing snow from the roof, do not apply strong force to the antenna. That may cause broken antenna and roof panel dent.**
- **When using a high pressure car wash, keep the high pressure nozzle away from the antenna. The seal may be deformed or damaged.**
- **The GNSS performance may be affected if cargo carried on the roof blocks the GNSS signal. If possible, do not put cargo near the antenna.**

5 Starting and driving

Precautions when starting and driving	5-5	Parking brake	5-24
Tire Pressure Monitoring System (TPMS)	5-5	Automatic operation	5-24
Avoiding collision and rollover	5-9	Manual operation	5-25
On-pavement and off-road driving precautions	5-9	Automatic brake hold	5-26
Off-road recovery	5-9	How to activate/deactivate the automatic brake hold function	5-27
Rapid air pressure loss	5-10	How to use the automatic brake hold function	5-28
Drinking alcohol/drugs and driving	5-10	Drive Mode Selector	5-29
Driving safety precautions	5-11	STANDARD mode	5-30
Push-button power switch	5-13	ECO mode	5-30
Intelligent Key system	5-13	SPORT mode	5-31
Operating range for EV system start function	5-13	SNOW mode (AWD models)	5-31
Power switch operation	5-14	Driver Assistance systems	5-32
Power switch positions	5-15	How to enable/disable the systems	5-34
Emergency EV system shut off	5-15	Driver assistance troubleshooting guide	5-36
Intelligent Key battery discharge	5-16	Traffic Sign Recognition (TSR)	5-40
Before starting the EV system	5-16	System operation	5-41
Starting the EV (Electric Vehicle) system	5-17	How to enable/disable the TSR system (if so equipped)	5-43
Driving the vehicle	5-17	System temporarily unavailable	5-43
Electric shift control system	5-17	System malfunction	5-43
e-Step system	5-21	System maintenance	5-44
e-Step system operation	5-21	Lane Departure Warning (LDW)	5-44
e-Step system limitations	5-23	LDW system operation	5-45
e-Step system malfunction	5-23		

How to enable/disable the LDW system	5-46	Rear Cross Traffic Alert (RCTA)	5-75
LDW system limitations	5-46	RCTA system operation	5-75
System temporarily unavailable	5-47	How to enable/disable the RCTA system	5-77
System malfunction	5-48	RCTA system limitations	5-78
System maintenance	5-48	System temporarily unavailable	5-80
Intelligent Lane Intervention (I-LI)	5-49	System malfunction	5-80
I-LI system operation	5-50	System maintenance	5-80
How to enable/disable the I-LI system	5-51	ProPILOT Assist Systems	5-82
I-LI system limitations	5-52	Overview	5-82
System temporarily unavailable	5-53	ProPILOT Assist Systems Overview	5-85
System malfunction	5-54	ProPILOT Assist 2.0 mode indicators	5-86
System maintenance	5-54	ProPILOT Assist displays and indicators	5-94
Blind Spot Warning (BSW)	5-55	Intelligent Cruise Control (ICC)	5-98
BSW system operation	5-56	Conventional (fixed speed)	
How to enable/disable the BSW system	5-57	cruise control	5-102
BSW system limitations	5-58	Speed Limit Assist	5-103
BSW driving situations	5-59	Speed Adjust by Route	5-105
System temporarily unavailable	5-61	Steering Assist	5-106
System malfunction	5-62	Hands On Detection	5-109
System maintenance	5-62	Driver Monitor	5-111
Intelligent Blind Spot Intervention (I-BSI)	5-63	Attention to the road	5-112
I-BSI system operation	5-65	Lane Change Assist	5-113
How to enable/disable the I-BSI system	5-66	Passing Assist	5-115
I-BSI system limitations	5-67	Route Assist	5-118
I-BSI driving situations	5-69	License information (ProPILOT	
System temporarily unavailable	5-73	Assist 2.0)	5-120
System malfunction	5-73		
System maintenance	5-73		

Automatic Emergency Braking (AEB) with Pedestrian Detection system	5-120	System malfunction	5-147
AEB with Pedestrian Detection system operation	5-121	System maintenance	5-147
Turning the AEB with Pedestrian Detection system ON/OFF	5-123	Increasing power economy	5-148
AEB with Pedestrian Detection system limitations	5-124	All-Wheel Drive (AWD) system (if so equipped)	5-149
System temporarily unavailable	5-127	Parking/parking on hills	5-150
System malfunction	5-128	Electric power steering	5-151
System maintenance	5-129	Brake system	5-152
Intelligent Forward Collision Warning (I-FCW)	5-130	Braking precautions	5-152
I-FCW system operation	5-132	Brake assist	5-153
Turning the I-FCW system ON/OFF	5-133	Brake assist	5-153
I-FCW system limitations	5-135	Anti-lock Braking System (ABS)	5-153
System temporarily unavailable	5-136	Vehicle Dynamic Control (VDC) system	5-155
System malfunction	5-137	How to turn off the VDC system	5-156
System maintenance	5-137	Brake Force Distribution	5-157
Intelligent Driver Alertness (I-DA)	5-139	Chassis control	5-158
I-DA system operation	5-139	Intelligent Trace Control	5-158
How to enable/disable the I-DA system	5-140	Hill Start Assist system	5-159
I-DA system limitations	5-141	Sonar system	5-160
System malfunction	5-141	System operation	5-161
Rear Automatic Braking (RAB)	5-141	How to enable/disable the sonar system	5-162
RAB system operation	5-143	Sonar system limitations	5-163
How to enable/disable Rear Automatic Braking	5-144	System temporarily unavailable	5-164
RAB system limitations	5-145	System maintenance	5-164
		ProPILOT Park (if so equipped)	5-165
		Overview	5-165
		How to operate ProPILOT Park	5-167
		ProPILOT Park operation	5-168

Parking space detection requirements	5-169	Tire equipment	5-174
Pause/deactivation of the system	5-171	Special winter equipment	5-174
ProPILOT Park settings	5-171	Parking brake	5-174
ProPILOT Park malfunctions	5-172	Corrosion protection	5-174
Cold weather driving	5-173	Freeing a frozen charge port lid	5-174
12-volt battery	5-173	Active sound enhancement (AWD models).....	5-175
Coolant	5-174		

PRECAUTIONS WHEN STARTING AND DRIVING



WARNING

- **Do not leave children or adults who would normally require the support of others alone in your vehicle. Pets should not be left alone either. They could accidentally injure themselves or others through inadvertent operation of the vehicle. Also, on hot, sunny days, temperatures in a closed vehicle could quickly become high enough to cause severe or possibly fatal injuries to people or animals.**
- **Properly secure all cargo with ropes or straps to help prevent it from sliding or shifting. Do not place cargo higher than the seat-backs. In a sudden stop or collision, unsecured cargo could cause personal injury.**

TIRE PRESSURE MONITORING SYSTEM (TPMS)

Each tire, including the spare (if provided), should be checked monthly when cold and inflated to the inflation pressure recommended by the vehicle manufacturer on the vehicle placard or tire inflation

pressure label. (If your vehicle has tires of a different size than the size indicated on the vehicle placard or tire inflation pressure label, you should determine the proper tire inflation pressure for those tires.)

As an added safety feature, your vehicle has been equipped with a Tire Pressure Monitoring System (TPMS) that illuminates a low tire pressure telltale when one or more of your tires is significantly under-inflated. Accordingly, when the low tire pressure telltale illuminates, you should stop and check your tires as soon as possible, and inflate them to the proper pressure. Driving on a significantly under-inflated tire causes the tire to overheat and can lead to tire failure. Under-inflation also reduces energy efficiency and tire tread life, and may affect the vehicle's handling and stopping ability.

Please note that the TPMS is not a substitute for proper tire maintenance, and it is the driver's responsibility to maintain correct tire pressure, even if under-inflation has not reached the level to trigger illumination of the TPMS low tire pressure telltale.

Your vehicle has also been equipped with a TPMS malfunction indicator to indicate when the system is not operating prop-

erly. The TPMS malfunction indicator is combined with the low tire pressure telltale. When the system detects a malfunction, the telltale will flash for approximately one minute and then remain continuously illuminated. This sequence will continue upon subsequent vehicle start-ups as long as the malfunction exists. When the malfunction indicator is illuminated, the system may not be able to detect or signal low tire pressure as intended. TPMS malfunctions may occur for a variety of reasons, including the installation of replacement or alternate tires or wheels on the vehicle that prevent the TPMS from functioning properly. Always check the TPMS malfunction telltale after replacing one or more tires or wheels on your vehicle to ensure that the replacement or alternate tires and wheels allow the TPMS to continue to function properly.

Additional information

- The TPMS will activate only when the vehicle is driven at speeds above 16 MPH (25 km/h). Also, this system may not detect a sudden drop in tire pressure (for example a flat tire while driving).
- The low tire pressure warning light does not automatically turn off when the tire pressure is adjusted. After the

tire is inflated to the recommended pressure, the vehicle must be driven at speeds above 16 MPH (25 km/h) to activate the TPMS and turn off the low tire pressure warning light. Use a tire pressure gauge to check the tire pressure.

- The “Tire Pressure Low - Add Air” warning appears in the vehicle information display when the low tire pressure warning light is illuminated and low tire pressure is detected. The “Tire Pressure Low - Add Air” warning turns off when the low tire pressure warning light turns off.

The “Tire Pressure Low - Add Air” warning does not appear if the low tire pressure warning light illuminates to indicate a TPMS malfunction.

- Tire pressure rises and falls depending on the heat caused by the vehicle’s operation and the outside temperature. Do not reduce the tire pressure after driving because the tire pressure rises after driving. Low outside temperature can lower the temperature of the air inside the tire which can cause a lower tire inflation pressure. This may cause the low tire pressure warning light to illuminate. If the warning light illuminates in low ambient temperature, check the tire pressure for all four tires.

- You can also check the tire pressure of all tires in the vehicle information display. (See “Trip computer” (P.2-45).)

For additional information, see “Low tire pressure warning light” (P.2-17) and “Tire Pressure Monitoring System (TPMS)” (P.6-3).



WARNING

- **Radio waves could adversely affect electric medical equipment. Those who use a pacemaker should contact the electric medical equipment manufacturer for the possible influences before use.**
- **If the low tire pressure warning light illuminates while driving, avoid sudden steering maneuvers or abrupt braking, reduce vehicle speed, pull off the road to a safe location and stop the vehicle as soon as possible. Driving with under-inflated tires may permanently damage the tires and increase the likelihood of tire failure. Serious vehicle damage could occur and may lead to an accident and could result in serious personal injury. Check the tire pressure for all four tires.**

Adjust the tire pressure to the recommended COLD tire pressure shown on the Tire and Loading Information label to turn the low tire pressure warning light OFF. If you have a flat tire, repair it with an emergency tire puncture repair kit as soon as possible. (See “Flat tire” (P.6-3).)

- Replacing tires with those not originally specified by NISSAN could affect the proper operation of the TPMS.
- NISSAN recommends using only Genuine NISSAN Emergency Tire Sealant provided with your vehicle or equivalent. Other tire sealants may damage the valve stem seal which can cause the tire to lose air pressure. It is recommended that you visit a NISSAN certified ARIYA dealer as soon as possible after using tire repair sealant.



CAUTION

- The TPMS may not function properly when the wheels are equipped with tire chains or the

wheels are buried in snow.

- Do not place metalized film or any metal parts (antenna, etc.) on the windows. This may cause poor reception of the signals from the tire pressure sensors, and the TPMS will not function properly.
- When inflating the tires and checking the tire pressure, never bend the valves.
- Use Genuine NISSAN valve caps that comply with the factory-fitted valve cap specifications.
- Do not use metal valve caps.
- Fit the valve caps properly. Without the valve caps the valve and tire pressure monitor sensors could be damaged.
- Do not damage the valves and sensors when storing the wheels or fitting different tires.
- Replace the TPMS sensor valve stem (including valve core and cap) and screw (if so equipped) when the tires are replaced due to wear or age. The screw (if so equipped) must be fitted correctly with a torque setting of 1.4 ± 0.1 N.m. The TPMS sensors can

be used again.

- Use caution when using tire inflation equipment with a rigid air supply tube, as leverage applied by the long nozzle can damage the valve stem.

Some devices and transmitters may temporarily interfere with the operation of the TPMS and cause the low tire pressure warning light to illuminate. Some examples are:

- Facilities or electric devices using similar radio frequencies are near the vehicle.
- If a transmitter set to similar frequencies is being used in or near the vehicle.
- If a computer (or similar equipment) or a DC/AC converter is being used in or near the vehicle.

Low tire pressure warning light may illuminate in the following cases.

- If the vehicle is equipped with a wheel and tire without TPMS.
- If the TPMS has been replaced and the ID has not been registered.
- If the wheel is not originally specified by NISSAN.

FCC Notice:

For USA:

Tire Pressure Monitoring System (TPMS) transmitter

FCC ID: KR5TIS-10DL

Body Control Module (BCM)



40406556

Continental

This device complies with Part 15 of the FCC Rules. Operation is subject to the following two conditions: (1) This device may not cause harmful interference, and (2) this device must accept any interference received, including interference that may cause undesired operation.

Note: Changes or modifications not expressly approved by the party responsible for compliance could void the user's authority to operate the equipment.

For Canada:

Tire Pressure Monitoring System (TPMS) transmitter

Continental

Model: TIS-10DL

IC: 7812D-TIS10DL

Body Control Module (BCM)

Model: 40406556

IC: 7812D-5235RXDP

Continental

This device contains licence-exempt transmitter(s)/receiver(s) that comply with Innovation, Science and Economic Development Canada's licence-exempt RSS(s). Operation is subject to the following two conditions: (1) This device may not cause interference. (2) This device must accept any interference, including interference that may cause undesired operation of the device.

TPMS with Easy Fill Tire Alert



WARNING

After rotating the tires, do not use the Easy-Fill Tire Alert to adjust the tire pressure. Instead use a gauge to adjust the tires to the correct pressure in accordance with Tire and Loading Information label.

When adding air to an under-inflated tire, the TPMS with Easy Fill Tire Alert provides visual and audible signals outside the

vehicle to help you inflate the tires to the recommended COLD tire pressure.

Vehicle set-up:

1. Park the vehicle in a safe and level place.
2. Apply the parking brake and push the park button to shift to the P (Park) position.
3. Place the power switch in the ON position. Do not start the EV system.

Operation:

1. Add air to the tire.
 2. After a few seconds, the hazard indicators will start flashing.
 3. When the designated pressure is reached, the horn beeps once and the hazard indicators stop flashing.
 4. Perform the above steps for each tire.
- If the tire is over-inflated more than approximately 4 psi (30 kPa), the horn beeps and the hazard indicators flash 3 times. To correct the pressure, push the core of the valve stem on the tire briefly to release pressure. When the pressure reaches the designated pressure, the horn beeps once.
 - If the hazard indicator does not flash within approximately 15 seconds after starting to inflate the tire, it indicates

that the TPMS with Easy Fill Tire Alert is not operating.

- The TPMS will not activate the Easy Fill Tire Alert under the following conditions:
 - If there is interference from an external device or transmitter
 - The air pressure from the inflation device such as those using a power socket is not sufficient to inflate the tire
 - If an electrical equipment is being used in or near the vehicle
 - There is a malfunction in the TPMS system
 - There is a malfunction in the horn or hazard indicators
- If the TPMS with Easy Fill Tire Alert does not operate due to TPMS interference, move the vehicle about 3 ft (1m) backward or forward and try again.

If the TPMS with Easy Fill Tire Alert is not working, use a tire pressure gauge.

AVOIDING COLLISION AND ROLL-OVER



WARNING

Failure to operate this vehicle in a safe and prudent manner may result in loss of control or an accident.

Be alert and drive defensively at all times. Obey all traffic regulations. Avoid excessive speed, high speed cornering, or sudden steering maneuvers, because these driving practices could cause you to lose control of your vehicle. **As with any vehicle, a loss of control could result in a collision with other vehicles or objects, or cause the vehicle to roll-over, particularly if the loss of control causes the vehicle to slide sideways.** Be attentive at all times, and avoid driving when tired. Never drive when under the influence of alcohol or drugs (including prescription or over-the-counter drugs which may cause drowsiness). Always wear your seat belt as outlined in “Seat belts” (P.1-14) of this manual, and also instruct your passengers to do so.

Seat belts help reduce the risk of injury in collisions and rollovers. **In a rollover crash, an unbelted person is significantly**

more likely to die than a person wearing a seat belt.

ON-PAVEMENT AND OFF-ROAD DRIVING PRECAUTIONS

Utility vehicles have a significantly higher rollover rate than other types of vehicles.

They have higher ground clearance than passenger cars to make them capable of performing in a variety of on-pavement and off-road applications. This gives them a higher center of gravity than ordinary cars. An advantage of higher ground clearance is a better view of the road, allowing you to anticipate problems. However, they are not designed for cornering at the same speeds as conventional passenger cars any more than low-slung sports cars are designed to perform satisfactorily under off-road conditions. If at all possible, avoid sharp turns or abrupt maneuvers, particularly at high speeds. As with other vehicles of this type, failure to operate this vehicle correctly may result in loss of control or vehicle rollover. Seat belts help reduce the risk of injury in collisions and rollovers. In a rollover crash, an unbelted person is significantly more likely to die than a person wearing a seat belt.

Be sure to read “Driving safety precau-

tions” (P.5-11).

OFF-ROAD RECOVERY

If the right side or left side wheels leave the road surface, maintain control of the vehicle by following the procedure below. Please note that this procedure is only a general guide. The vehicle must be driven as appropriate based on the conditions of the vehicle, road and traffic.

1. Remain calm and do not overreact.
2. Do not apply the brakes.
3. Maintain a firm grip on the steering wheel with both hands and try to hold a straight course.
4. When appropriate, slowly release the accelerator pedal to gradually slow the vehicle.
5. If there is nothing in the way, steer the vehicle to follow the road while the vehicle speed is reduced. Do not attempt to drive the vehicle back onto the road surface until vehicle speed is reduced.
6. When it is safe to do so, gradually turn the steering wheel until both tires return to the road surface. When all tires are on the road surface, steer the vehicle to stay in the appropriate driving lane.

- If you decide that it is not safe to return the vehicle to the road surface based on vehicle, road or traffic conditions, gradually slow the vehicle to a stop in a safe place off the road.

RAPID AIR PRESSURE LOSS

Rapid air pressure loss or a “blow-out” can occur if the tire is punctured or is damaged due to hitting a curb or pothole. Rapid air pressure loss can also be caused by driving on under-inflated tires.

Rapid air pressure loss can affect the handling and stability of the vehicle, especially at highway speeds.

Help prevent rapid air pressure loss by maintaining the correct air pressure and visually inspect the tires for wear and damage. See “Wheels and tires” (P.8-18) of this manual.

If a tire rapidly loses air pressure or “blows-out” while driving, maintain control of the vehicle by following the procedure below. Please note that this procedure is only a general guide. The vehicle must be driven as appropriate based on the conditions of the vehicle, road and traffic.

WARNING

The following actions can increase the chance of losing control of the vehicle if there is a sudden loss of tire air pressure. Losing control of the vehicle may cause a collision and result in personal injury.

- **The vehicle generally moves or pulls in the direction of the flat tire.**
- **Do not rapidly apply the brakes.**
- **Do not rapidly release the accelerator pedal.**
- **Do not rapidly turn the steering wheel.**

1. Remain calm and do not overreact.
2. Maintain a firm grip on the steering wheel with both hands and try to hold a straight course.
3. When appropriate, slowly release the accelerator pedal to gradually slow the vehicle.
4. Gradually steer the vehicle to a safe location off the road and away from traffic if possible.

5. Lightly apply the brake pedal to gradually stop the vehicle.
6. Turn on the hazard warning flashers and either contact a roadside emergency service to change the tire or see “Repairing flat tire” (P.6-4) of this Owner’s Manual.

DRINKING ALCOHOL/DRUGS AND DRIVING

WARNING

Never drive under the influence of alcohol or drugs. Alcohol in the bloodstream reduces coordination, delays reaction time and impairs judgement. Driving after drinking alcohol increases the likelihood of being involved in an accident injuring yourself and others. Additionally, if you are injured in an accident, alcohol can increase the severity of the injury.

NISSAN is committed to safe driving. However, you must choose not to drive under the influence of alcohol. Every year thousands of people are injured or killed in alcohol-related accidents. Although the local laws vary on what is considered to be legally intoxicated, the fact is that

alcohol affects all people differently and most people underestimate the effects of alcohol.

Remember, drinking and driving don't mix! And that is true for drugs, too (over-the-counter, prescription, and illegal drugs). Don't drive if your ability to operate your vehicle is impaired by alcohol, drugs, or some other physical condition.

DRIVING SAFETY PRECAUTIONS

Your vehicle is designed for both normal and off-road use. However, avoid driving in deep water or mud as your vehicle is mainly designed for leisure use, unlike a conventional off-road vehicle.

Remember that Two-Wheel Drive (2WD) models are less capable than All-Wheel Drive (AWD) models for rough road driving and extrication when stuck in deep snow, mud, or the like.

Please observe the following precautions:



WARNING

- **Drive carefully when off the road and avoid dangerous areas. Every person who drives or rides in this vehicle should be seated with their seat belt fastened. This will keep you and your passengers in**

position when driving over rough terrain.

- **Do not drive across steep slopes. Instead drive either straight up or straight down the slopes. Off-road vehicles can tip over sideways much more easily than they can forward or backward.**
- **Many hills are too steep for any vehicle. If you drive up them, you may stall. If you drive down them, you may not be able to control your speed. If you drive across them, you may roll over.**
- **Do not shift ranges while driving on downhill grades as this could cause loss of control of the vehicle.**
- **Stay alert when driving to the top of a hill. At the top there could be a drop-off or other hazard that could cause an accident.**
- **If your EV system stalls or you cannot make it to the top of a steep hill, never attempt to turn around. Your vehicle could tip or roll over. Always back straight down in R (Reverse) range. Never back down in N (Neutral), using only the brake, as this could cause loss of control.**

- **Heavy braking going down a hill could cause your brakes to over-heat and fade, resulting in loss of control and an accident. Apply brakes lightly and use a low range to control your speed.**
- **Unsecured cargo can be thrown around when driving over rough terrain. Properly secure all cargo so it will not be thrown forward and cause injury to you or your passengers.**
- **To avoid raising the center of gravity excessively, do not exceed the rated capacity of the roof rack (if so equipped) and evenly distribute the load. Secure heavy loads in the cargo area as far forward and as low as possible. Do not equip the vehicle with tires larger than specified in this manual. This could cause your vehicle to roll over.**
- **Do not grip the inside or spokes of the steering wheel when driving off-road. The steering wheel could move suddenly and injure your hands. Instead drive with your fingers and thumbs on the outside of the rim.**

- Before operating the vehicle, ensure that the driver and all passengers have their seat belts fastened.
- Always drive with the floor mats in place as the floor may become hot.
- Lower your speed when encountering strong crosswinds. With a higher center of gravity, your vehicle is more affected by strong side winds. Slower speeds ensure better vehicle control.
- Do not drive beyond the performance capability of the tires, even with AWD engaged.
- For AWD equipped vehicles, do not attempt to raise two wheels off the ground and shift the transmission to any drive or reverse position with the EV system running. Doing so may result in drivetrain damage or unexpected vehicle movement which could result in serious vehicle damage or personal injury.
- Do not attempt to test an AWD equipped vehicle on a 2-wheel dynamometer, or similar equipment even if the other two wheels are raised off the ground. Make

sure you inform test facility personnel that your vehicle is equipped with AWD before it is placed on a dynamometer. Using the wrong test equipment may result in drivetrain damage or unexpected vehicle movement which could result in serious vehicle damage or personal injury.

- When a wheel is off the ground due to an unlevel surface, do not spin the wheel excessively (AWD model).
- Accelerating quickly, sharp steering maneuvers or sudden braking may cause loss of control.
- If at all possible, avoid sharp turning maneuvers, particularly at high speeds. Your vehicle has a higher center of gravity than a conventional passenger car. The vehicle is not designed for cornering at the same speeds as conventional passenger cars. Failure to operate this vehicle correctly could result in loss of control and/or a rollover accident.
- Always use tires of the same type, size, brand, construction (bias, bias-belted or radial), and tread

pattern on all four wheels. Install traction devices on the front wheels when driving on slippery roads and drive carefully.

- Be sure to check the brakes immediately after driving in mud or water. See "Brake system" (P.5-152) for wet brakes.
- Avoid parking your vehicle on steep hills. If you get out of the vehicle and it rolls forward, backward or sideways, you could be injured.
- Whenever you drive off-road through sand, mud or water as deep as the wheel hub, more frequent maintenance may be required. See the maintenance schedule shown in the "9. Maintenance and schedules" section.

PUSH-BUTTON POWER SWITCH



WARNING

Do not operate the push-button power switch while driving the vehicle except in an emergency. (The EV system will stop when the power switch is pushed 3 consecutive times or the power switch is pushed and held for more than 2 seconds.) If the EV system stops while the vehicle is being driven, this could lead to a crash and serious injury.

Before operating the push-button power switch, be sure to push the park button to shift to the P (Park) position.

INTELLIGENT KEY SYSTEM

The Intelligent Key system can be used to operate the power switch without taking the key out from your pocket or bag. The operating environment and/or conditions may affect the Intelligent Key system operation.

Some indicators and warnings for operation are displayed on the vehicle information display. See "Vehicle information display" (P.2-22).



CAUTION

- Be sure to carry the Intelligent Key with you when operating the vehicle.
- Never leave the Intelligent Key inside the vehicle when you leave the vehicle.
- If the 12-volt battery is discharged, the power switch cannot be switched from the OFF position, the steering wheel cannot be moved. Charge the 12-volt battery as soon as possible. See "Jump starting" (P.6-15).

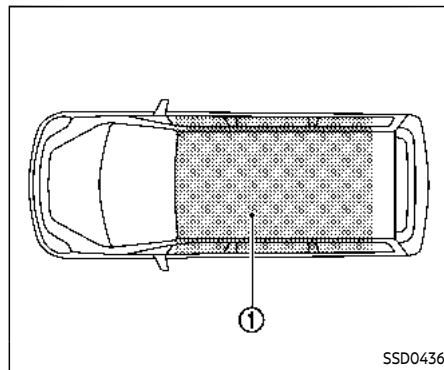

OPERATING RANGE FOR EV SYSTEM START FUNCTION

The Intelligent Key can only be used for starting the EV system when the Intelligent Key is within the specified operating range ①.

When the Intelligent Key battery is almost discharged or strong radio waves are present near the operating location, the Intelligent Key system's operating range becomes narrower and may not function properly.

If the Intelligent Key is within the operating range, it is possible for anyone, even someone who does not carry the Intelligent Key, to push the power switch to

start the EV system.

- The cargo room area is not included in the operating range but the Intelligent Key may function.
- If the Intelligent Key is placed on the instrument panel, inside the glove box, multi center storage or door pocket, the Intelligent Key may not function.
- If the Intelligent Key is placed near the door or window outside the vehicle, the Intelligent Key may function.

If the battery of the Intelligent Key is discharged, see "Intelligent Key battery discharge" (P.5-16).

POWER SWITCH OPERATION



CAUTION

- **Do not leave the vehicle for extended periods of time when the power switch is in the ON position and the EV system is not running. This can discharge the battery.**
- **Use electrical accessories with the EV system running to avoid discharging the vehicle battery. If you must use accessories while the EV system is not running, do not use them for extended periods of time and do not use multi-**

Do not use multiple electrical accessories at the same time.

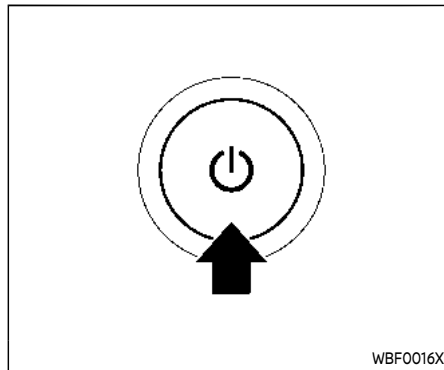

When the power switch is pushed without depressing the brake pedal, the power switch position will change as follows.

- once to change to ON.
- two times to change to OFF.

When the power switch cannot be switched to the OFF position, proceed as follows.

1. Push the park button on the shift lever to place the vehicle in the P (Park) position.
2. Push the power switch. The power switch position will change to the ON position.

3. Push the power switch again to the OFF position.

POWER SWITCH POSITIONS

ON

All the electrical power activate at this position.

The ON position has a battery saver feature that will place the power switch in the OFF position after a period of time under the following conditions:

- The power switch is in the ON position and the READY to drive indicator light is not illuminated.
- Vehicle is parked.

READY (Normal operating position)

This position turns on the EV system, electrical accessories and the vehicle can be driven.

OFF

The EV system is turned off in this position.

Auto ACC

Even when the power switch is in the OFF position, the Auto ACC function automatically switches to the state where electrical components such as the navigation system and door mirrors can be used (ACC state) under specific conditions. You

can use the navigation system, door mirrors, etc. even after the EV system is stopped or before the power switch is turned ON.

The Auto ACC function is activated in the following cases.

- When the door is unlocked using the Intelligent Key function.
- When the power switch is placed in the OFF position.

The Auto ACC function will be stopped in the following cases.

- After a period of time have passed without operating the navigation system or audio system.
- After approximately 1 minute has passed since the EV system was stopped and the vehicle has been locked with the Intelligent Key function.
- After a period of time have passed since the driver's door is opened and then closed without locking the doors.

The Auto ACC function can be extended up to 30 minutes by operating the navigation system. If it is extended, other electrical components such as door mirrors can also be used. The ACC state cannot be extended by operating an electrical components other than the navigation system or audio system.



CAUTION

To prevent the 12V battery from discharging, use the electrical components (navigation system, power socket, etc.) with the EV system started.

EMERGENCY EV SYSTEM SHUT OFF

To shut off the EV system in an emergency situation while driving or when the Intelligent Key battery is discharged, perform the following procedure:

- Rapidly push the push-button power switch 3 consecutive times in less than 1.5 seconds, or
 - Push and hold the push-button power switch for more than 2 seconds.
- After EV system shut-off, open the door to return to the normal condition.

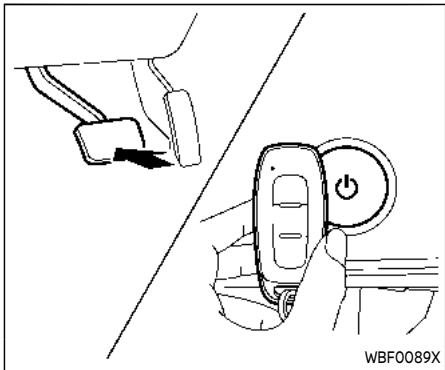

INTELLIGENT KEY BATTERY DISCHARGE

If the battery of the Intelligent Key is discharged, or environmental conditions interfere with the Intelligent Key operation, start the EV (Electric Vehicle) system in the READY to drive mode according to the following procedure:

1. Push the park button to shift to the P (Park) position.
2. Firmly apply the foot brake.
3. Push the power switch.
4. Touch the power switch with the Intelligent Key as illustrated. (A chime will sound.)

5. Push the power switch while depressing the brake pedal within 10 seconds after the chime sounds. The power switch position changes to READY to drive.

After step 3 is performed, when the power switch is pushed without depressing the brake pedal, the power switch position will change to ON.

NOTE:

- **When the power switch is pushed to the ON position or READY to drive position by the above procedures, the "Key Battery Low" warning may appear (on the vehicle information display) even if the Intelligent Key is inside the vehicle. This is not a malfunction. To turn off the warning, touch the power switch with the Intelligent Key again.**
- **If the "Key Battery Low" warning appears, replace the battery as soon as possible. (See "Intelligent Key battery replacement" (P.8-13).)**

BEFORE STARTING THE EV SYSTEM



WARNING

The driving characteristics of your vehicle will change remarkably by any additional load and its distribution, as well as by adding optional equipment (trailer coupling, roof racks, etc.). Your driving style and speed must be adjusted according to the circumstances. Especially when carrying heavy loads, your speed must be reduced adequately.

- Make sure the area around the vehicle is clear.
- Visually inspect tires for their appearance and condition. Measure and check the tire pressure for proper inflation.
- Check that all windows and lights are clean.
- Adjust the seat and head restraint/headrest positions.
- Adjust the inside and outside rearview mirror positions.
- Fasten your seat belt and ask all passengers to do the same.
- Check that all doors are locked.
- Check the operation of the warning lights when the power switch is

- placed in the ON position.
- Maintenance items in the “8. Maintenance and do-it-yourself” section should be checked periodically.

STARTING THE EV (Electric Vehicle) SYSTEM

1. Confirm the parking brake is applied.
2. Confirm that the vehicle is in the P (Park) position.

The EV (Electric Vehicle) is designed not to operate unless the shift position is in the P (Park) or N (Neutral) positions.

The Intelligent Key must be carried with you when operating the power switch.

3. Firmly depress the brake pedal and push the power switch to place the EV system in the READY to drive position.

To place the vehicle in the READY to drive position immediately, push and release the power switch while depressing the brake pedal with the power switch in any position. The READY to drive indicator light READY in the meter illuminates.

4. To stop the EV system, push the park button on the shift lever, and push the power switch to the OFF position.

DRIVING THE VEHICLE

ELECTRIC SHIFT CONTROL SYSTEM

This vehicle is electronically controlled to produce maximum available power and smooth operation.

The recommended operating procedures for this vehicle are shown on the following pages.

Starting vehicle

1. After placing the vehicle in the READY to drive position, fully depress the foot brake pedal before moving the shift lever to the D (Drive) position.

The shift lever of this vehicle is designed so that the foot brake pedal must be depressed before shifting from the P (Park) position to any driving position while the power switch is in the READY to drive position.

The shift position cannot be moved out of the P (Park) position and into any of the other positions if the power switch is placed in the OFF position.

2. Keep the foot brake pedal depressed, and move the shift lever to the D (Drive) position.
3. Release the parking brake and foot brake pedal, and then gradually start the vehicle in motion.

WARNING

- Do not depress the accelerator pedal while shifting from P (Park) or N (Neutral) to R (Reverse) or D (Drive) position. Always depress the brake pedal until shifting is completed. Failure to do so could cause you to lose control, which could result in an accident.
- Never shift to either the P (Park) or R (Reverse) position while the vehicle is moving forward and P (Park), D (Drive) position while the vehicle reversing. This could cause an accident or damage the transmission.

CAUTION

- To avoid possible damage to your vehicle, when stopping the vehicle on an uphill slope, do not hold the vehicle by depressing the accelerator pedal. The foot brake should be used for this purpose.
- Do not hang items on the shift lever. This may cause an accident due to a sudden start.

- Do not shift to the B position abruptly on slippery roads. This may cause a loss of control.

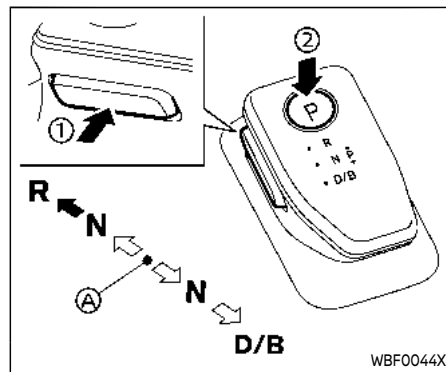

Ⓐ Home position (central position)

To move the shift lever,

➡: Push the button ① to shift.

⇨: Shift without pushing the button ①.

Shifting

Push the park button ② to shift to the "P" (Park) position.

NOTE:

- Confirm that the vehicle is in the desired shift position by checking the shift indicator located on the shift lever or on the vehicle information display.

- To place the vehicle into the D (Drive) position from the B position, move the shift lever into the D (Drive) position.

When moving the shift lever into the D (Drive) position again from the D (Drive) position, the position will be changed to B position.

- An operating noise may be heard when operating the shift lever. This is not a malfunction.

After placing the power switch in the READY to drive position, fully depress the brake pedal, and move the shift lever to any of the preferred shift positions.

NOTE:

- The vehicle automatically applies the P (Park) position when the power switch is in the OFF position.
- When the READY to drive indicator light does not illuminate, the shift position cannot be changed to the D (Drive), B or R (Reverse) position even if the power switch is placed in the ON position.
- If the following conditions have been met, the shift position may be changed to the P (Park) position automatically.
 - When the driver's seat belt is not fastened.

- When the driver's door is opened.



WARNING

- The shift lever is always in the center position when released. When the power switch is placed in the READY to drive position, the driver needs to confirm that the vehicle is in the P (Park) position. The indicator next to the "P" by the shift lever is illuminated and the "P" is displayed on the vehicle information display. If the vehicle is in the D (Drive) or R (Reverse) position when the power switch is placed in the READY to drive position, this may cause a sudden start which could result in an accident.
- On a hilly road, do not allow the vehicle to roll backwards while in the D (Drive) position or B position, or allow the vehicle to roll forward while in the R (Reverse) position. This may cause an accident.
- Do not operate the shift lever while the accelerator pedal is depressed, except when switching to the B position. This may

cause a sudden start which could result in an accident.



CAUTION

- Do not slide the shift lever while pushing the park button. This may also damage the electric motor.
 - When switching to the preferred position by operating the shift lever, check that the shift lever returns to the central position by releasing your hand from the lever. Holding the shift lever in a mid-way position may also damage the shift control system.
 - The following operations are not allowed because excessive force would be applied to the traction motor and this may result in damage to the vehicle:
 - Moving the shift lever to the R (Reverse) position when driving forward
 - Moving the shift lever to the D (Drive) or B position when reversing
- If these operations are at-

tempted, a chime sounds and the vehicle shifts to the N (Neutral) position.

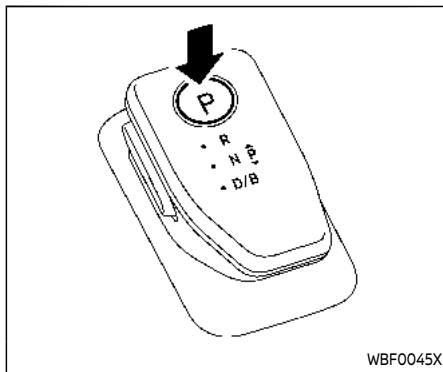

P (Park):

Use this position when the vehicle is parked or when placing the vehicle in the READY to drive position. Make sure that the vehicle is completely stopped. **In order to switch to the P (Park) position, push the park button as shown in the illustration once the vehicle has come to a complete stop. If the park button is pushed while the vehicle is in motion, a chime sounds and the current shift position is maintained.** After switching to the P (Park) position, apply the parking brake. When parking on a hill, apply the parking brake first while keeping the foot brake pedal depressed then push the park button and place the vehicle in the

P (Park) position. See "Parking brake" (P.5-24).

NOTE:

- While the vehicle is stationary, if the shift position is placed in any position other than the P (Park) position when the power switch is set to OFF, it will automatically switch to the P (Park) position.
- If the park button is pushed while sliding the shift lever, the shift position will not switch to the P (Park) position. When pushing the park button, be sure to first allow the shift lever to return to its center position.

R (Reverse):

Use this position to back up. Make sure that the vehicle is completely stopped before selecting the R (Reverse) position. **If the vehicle is placed in the D (Drive) position while reversing, the chime will sound and the vehicle will switch into the N (Neutral) position.**

N (Neutral):

Neither forward nor reverse gear is engaged. The vehicle can be placed in READY to drive position in this position.

Do not shift to the N (Neutral) position while driving. The regenerative brake system does not operate in the N (Neu-

tral) position. However, the vehicle brakes will still stop the vehicle.

D (Drive):

Use this position for all normal forward driving. **If the vehicle is placed in the D (Drive) position while reversing, the chime will sound and the vehicle will switch into the N (Neutral) position.**

B:

Use the B position for downhill driving. When the B position is used, more regenerative brake is applied when the accelerator pedal is released in comparison to the D (Drive) position. Less deceleration is provided by the regenerative brake system when the Li-ion battery is fully charged or the battery temperature is low.

e-Step SYSTEM



WARNING

Never rely solely on the e-Step system, as there is a performance limit to the system function. Always drive carefully and attentively. The brake pedal should be operated depending on traffic or road conditions.

The e-Step system enables the driver to slow the vehicle by operating only the accelerator pedal. This system helps to keep the driver from moving his/her foot between the accelerator pedal and the brake pedal.

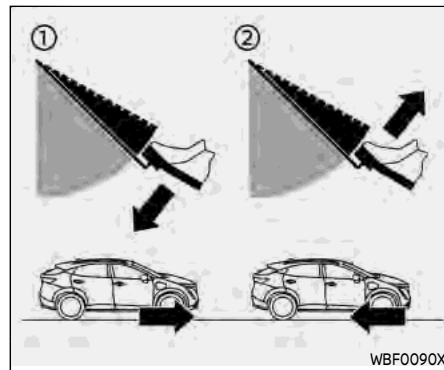

- ① Acceleration
- ② Deceleration (instead of brake pedal)

e-Step SYSTEM OPERATION

When the e-Step system is activated, the regenerative brake is enhanced and the driver can adjust the vehicle speed by only depressing or returning the accelerator pedal. When you release (take your foot off) the accelerator pedal, the vehicle slows down smoothly without depressing the brake pedal.

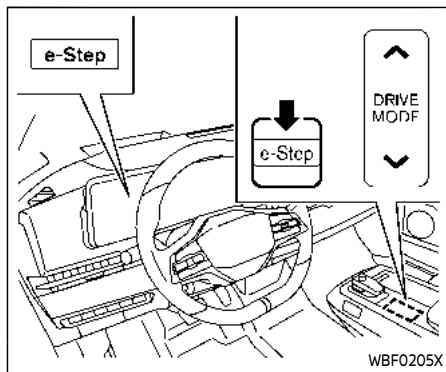

The e-Step system will be turned ON or OFF each time the e-Step switch (located on the center console) is pushed. (The e-Step indicator in the vehicle information display shows the status of the e-Step system.)

When the e-Step system is activated, the characteristics of the accelerator pedal change significantly and the accelerator pedal operates differently than a conventional accelerator pedal operates. Be sure to confirm the status of the e-Step system (ON or OFF) in the vehicle information display before driving.

When the e-Step system is activated, the e-Step indicator illuminates in blue and

displays "e-Step". When the e-Step system is turned off, the indicator changes to gray and displays "e-Step OFF".

System Activation

To activate the e-Step system, place the power switch in the READY to drive or ON position and push the e-Step switch.

System deactivation

To deactivate the e-Step system, with the power switch in the READY to drive or ON position, push the e-Step switch.

NOTE:

- **When the e-Step system is switched to ON or OFF, the degree of vehicle deceleration will change.**
- **The e-Step system is automatically turned OFF when the EV system is restarted.**
- **To keep the e-Step system activated even if the EV system is restarted, turn the "Retain Mode" ON in the "Driver Assistance" menu of the vehicle information display. (See "Settings" (P.2-25).)**
- **The "Retain Mode" setting is not reset by using the "Factory Reset" setting.**

e-Step driving features

The e-Step system provides the following driving features:

When driving the vehicle:

- Depressing or returning the accelerator pedal will change the degree of acceleration and deceleration accordingly.
- Returning the accelerator pedal generates more deceleration than normal. (The maximum deceleration changes according to the vehicle speed.)
- Releasing (taking your foot off) the accelerator pedal reduces the vehicle speed. To stop the vehicle, depress the brake pedal.
- The vehicle's stop lights illuminate when the deceleration level reaches an ordinary braking operation.

If the deceleration is not sufficient when the accelerator pedal is returned or released, depress the brake pedal. The brake pedal can be operated to reduce the vehicle speed in the same way as normal even when the e-Step system is activated.

When backing up the vehicle:

With the shift position in the R (Reverse), the accelerator pedal can be used in the same way as in the e-Step system is off.

Other driving tips for the e-Step system:

- For smooth deceleration when the e-Step system is activated, it is recommended to adjust the accelerator pedal while driving with your foot on it (depressing or returning, but not releasing).
- Shifting the shift position from D (Drive) to B or from B to D will not affect the e-Step system feature.
- The e-Step system will not function under the following conditions:
 - When the vehicle is placed in the P (Park) or N (Neutral) position.
 - When the Intelligent Cruise Control (ICC), ProPILOT Assist or Automatic Emergency Braking (AEB) with Pedestrian Detection are operated.
- Brake pedal may move depending on deceleration and you may feel a noise when e-Step is active. This is a normal system operation.

e-Step SYSTEM LIMITATIONS



WARNING

Listed below are the system limitations for the e-Step system. Failure to operate the vehicle in accordance with these system limitations could result in serious injury or death.

- **If the deceleration force provided by the e-Step system is not sufficient, depress the brake pedal.**
- **Under the following conditions the e-Step system may not decelerate the vehicle sufficiently. Depress the brake pedal whenever necessary.**
 - **When excessively heavy baggage is loaded in the vehicle.**
 - **When driving on steep downhill roads.**
 - **When driving on icy roads.**
- **Do not use the e-Step system when towing a trailer or other vehicle (AWD models).**



CAUTION

- **The characteristics of deceleration changes according to the vehicle speed. At very low speeds, the vehicle "creeps", similar to the e-Step system is deactivated.**
- **Be careful not to operate the e-Step switch mistakenly or unintentionally.**

e-Step SYSTEM MALFUNCTION

If the e-Step system malfunctions, "e-Step system failure Press brake pedal to slow or stop" warning message appears on the vehicle information display. When the warning message appears, the e-Step system will be turned off automatically. Have the system checked as soon as possible. It is recommended that you visit a NISSAN certified ARIYA dealer.

PARKING BRAKE

WARNING

- Never drive the vehicle with the parking brake applied. The brake will overheat and fail to operate and will lead to an accident.
- Never release the parking brake from outside the vehicle. If the vehicle moves, it will be impossible to push the foot brake pedal and will lead to an accident.
- Never use the shift lever in place of the parking brake. When parking, be sure the parking brake is fully applied.
- To help avoid risk of injury or death through unintended operation of the vehicle and/or its systems, do not leave children, people who require the assistance of others or pets unattended in your vehicle. Additionally, the temperature inside a closed vehicle on a warm day can quickly become high enough to cause a significant risk of injury or death to people and pets.

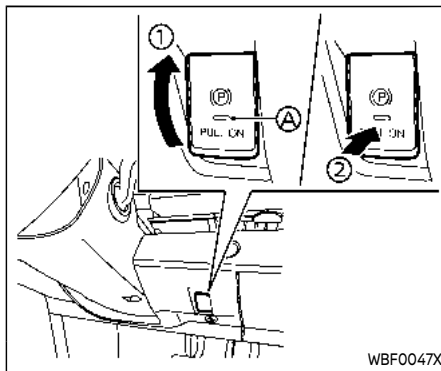

- ① Apply
- ② Release
- Ⓐ Indicator light

The electronic parking brake can be applied or released automatically or by operating the parking brake switch.

AUTOMATIC OPERATION

The electronic parking brake is automatically released as soon as the vehicle starts while the accelerator pedal is depressed under the following conditions.

- While the EV system is running.
- When the shift position is in the D (Drive) or R (Reverse) position.

- When the driver's door is closed. The electronic parking brake is automatically released within 5 seconds after the shift position is placed in the D (Drive) or R (Reverse) position even if the driver's door is opened. Be sure to close the door before starting the vehicle.

WARNING

Before leaving the vehicle, place the shift position in the P (Park) position and check that the electronic parking brake warning light is illuminated to confirm that the electronic parking brake is applied. The electronic parking brake warning light will remain on for a period of time after the driver's door is locked.

CAUTION

When parking in an area where the outside temperature is below 32°F (0°C), the electronic parking brake, if applied, may freeze in place and may be difficult to release.

For safe parking, it is recommended that you place the shift position in

the P (Park) position and securely block the wheels.

NOTE:

- To keep the electronic parking brake released after the EV system is turned off, place the power switch in the OFF position, depress the brake pedal and push down the parking brake switch before opening the driver's door.
- If a malfunction occurs in the electronic parking brake system (for example, due to battery discharge), it is recommended to contact a NISSAN certified ARIYA dealer.
- Under the following conditions, the electronic parking brake will automatically be applied and the brake force of the automatic brake hold will be released.
 - The braking force is applied by the automatic brake hold function for 3 minutes or longer.
 - The vehicle is in the P (Park) position.
 - The electronic parking brake is applied manually.
 - The driver's seat belt is unfastened.

- The driver's door is opened.
 - The power switch is placed in the OFF position.
 - A malfunction occurs in the automatic brake hold function.
- Make sure that the electronic parking brake system warning light is OFF before starting the vehicle.

MANUAL OPERATION

To apply: When the vehicle is stopped, pull the parking brake switch ② up. (The electronic parking brake will apply even if the power switch is placed in the OFF position.) The indicator light ④ on the switch and the electronic parking brake warning light PARK or ⑤ (red) will illuminate.

To release: With the power switch in the ON position, depress the brake pedal and push the parking brake switch down ①. The indicator light ④ and the electronic parking brake warning light (red) will turn off.

Before driving, check that the electronic parking brake warning light (red) turns off. For additional information, see "Warning lights, indicator lights and audible reminders" (P.2-11).

NOTE:

- While the electronic parking brake is applied or released, an operating sound is heard from the lower side of the rear seat. This is normal and does not indicate a malfunction.
- When the electronic parking brake is frequently applied and released in a short period of time, the electronic parking brake system warning light may blink and the electronic parking brake may not operate in order to prevent the electronic parking brake system from overheating. If this occurs, operate the parking brake switch again after waiting approximately 1 minute.
- If the electronic parking brake must be applied while driving in an emergency, pull up and hold the parking brake switch. When you release the parking brake switch, the electronic parking brake will be released.
- While pulling up the parking brake switch during driving, the electronic parking brake is applied and a chime sounds. The electronic parking brake warning light (red) and the indicator light on the parking brake switch illuminate. This does not indicate a malfunction. The electronic parking brake warning light (red) and the indicator light on the park-

AUTOMATIC BRAKE HOLD

ing brake switch will turn off when the electronic parking brake is released.

- **When pulling the parking brake switch up with the power switch in the OFF position, the indicator light on the parking brake switch will continue to illuminate for a short period of time.**

When towing a trailer (AWD models)

Depending on the weight of the vehicle and trailer and the steepness of the slope, there may be a tendency for the vehicle to move backwards when starting from a standstill. When this occurs, you can use the parking brake switch in the same way as a conventional lever type parking brake.

Before starting on sloping roads when towing a trailer, be sure to read the following to prevent the vehicle from moving backward unintentionally.

- Release the parking brake switch as soon as the EV system is delivering enough torque to the wheels.

The automatic brake hold function maintains the braking force without the driver having to depress the brake pedal when the vehicle is stopped at a traffic light or intersection. As soon as the driver depresses the accelerator pedal again, the automatic brake hold function is deactivated and the braking force is released. The operating status of the automatic brake hold can be displayed. (See “Warning lights, indicator lights and audible reminders” (P.2-11).)



WARNING

- **The automatic brake hold function is not designed to hold the vehicle on a steep hill or slippery road. Never use the automatic brake hold function when the vehicle is stopped on a steep hill or slippery road. Failure to do so may cause the vehicle to move.**
- **Warnings may appear to request that the driver retake control by depressing the brake pedal.**
- **When the automatic brake hold function is activated but fails to maintain the vehicle at a standstill, depress the brake pedal to stop the vehicle. If the vehicle unexpectedly moves due to out-**

side conditions, the chime may sound and warnings may appear.

- **Be sure to deactivate the automatic brake hold function when using a drive-thru car wash or towing your vehicle.**
- **Make sure the vehicle is in the P (Park) position and apply the electronic parking brake when parking your vehicle, riding on or off the vehicle, or loading or unloading luggage. Failure to do so could cause the vehicle to move or roll away unexpectedly and result in serious personal injury or property damage.**
- **If any of the following conditions occur, the automatic brake hold function may not function. Have the system checked promptly. It is recommended that you visit a NISSAN certified ARIYA dealer for this service.**

– A warning message appears.

– The indicator light on the automatic brake hold switch does not illuminate when the switch is pushed.

Failure to operate the vehicle in accordance with these conditions could cause the vehicle to move

or roll away unexpectedly and result in serious personal injury or property damage.

- The automatic brake hold function will not be activated if the slip indicator light, electronic parking brake warning light, brake system warning light, or master warning light illuminates and the Chassis control system Error warning message appears.

NOTE:

To maintain the braking force to keep the vehicle to a standstill, a noise may be heard. This is not a malfunction.

The automatic brake hold function is operated by applying sufficient braking force to hold the vehicle in its place, so there are cases when this hold function is maintained even if the accelerator pedal is depressed. In this situation, it is advised to depress the brake pedal first, then to turn off the automatic brake hold switch. This will cancel the hold function.

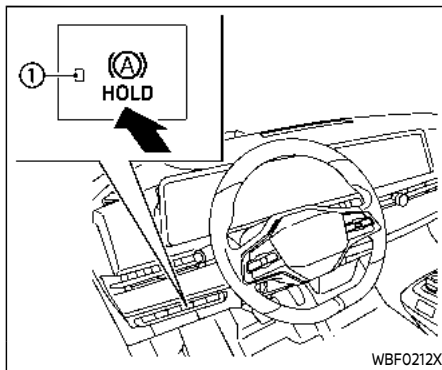

HOW TO ACTIVATE/DEACTIVATE THE AUTOMATIC BRAKE HOLD FUNCTION

How to activate the automatic brake hold function

1. With the power switch in the ON position, push the automatic brake hold switch. The indicator light ① on the automatic brake hold switch illuminates.
2. When the automatic brake hold function goes into standby, the automatic brake hold indicator light (white) illuminates.

To use the automatic brake hold function,

the following conditions need to be met.

- The driver's seat belt is fastened.
- The electronic parking brake is released.
- The vehicle is not in the P (Park) position.
- The vehicle is not parked on a steep hill.

NOTE:

The automatic brake hold function retains the last state until the driver changes the option even if the power switch is turned off.

How to deactivate the automatic brake hold function

While the automatic brake hold function is activated, push the automatic brake hold switch to turn off the automatic brake hold indicator light and deactivate the automatic brake hold function. To deactivate the automatic brake hold function while the brake force has been maintained by the automatic brake hold function, depress the brake pedal and push the automatic brake hold switch.



WARNING

Make sure to firmly depress and hold the brake pedal when turning off the automatic brake hold function while the brake force is applied. When the automatic brake hold function is deactivated, the brake force will be released. This could cause the vehicle to move or roll away unexpectedly.

Failure to prevent the vehicle from rolling may result in serious personal injury or property damage.

HOW TO USE THE AUTOMATIC BRAKE HOLD FUNCTION

For additional information on using the automatic brake hold function, refer to the instructions outlined in this section.

To maintain braking force automatically

With the automatic brake hold function activated and the automatic brake hold indicator light (white) illuminated, depress the braking pedal to stop the vehicle, and the indicator light (green) illuminates. The brake force is automatically applied without your foot depressed on the brake

pedal. While the brake force is maintained, the automatic brake hold indicator light (green) illuminates.

NOTE:

The automatic brake hold indicator light (green) will not illuminate if the brake pedal is not depressed with sufficient force to hold the vehicle or is released too quickly when the vehicle is stopped.



CAUTION

Confirm the automatic brake hold indicator light (green) is illuminated before removing your foot from the brake pedal.

To start the vehicle from a standstill

With the vehicle not in the P (Park) or the N (Neutral) position, depress the accelerator pedal while the brake force is maintained. The brake force will automatically be released to restart the vehicle. The automatic brake hold indicator light (white) illuminates and the automatic brake hold returns to standby.

Parking

When the vehicle is in the P (Park) position with the brake force maintained by the automatic brake hold function, the electronic parking brake will automatically be applied and the brake force of the automatic brake hold will be released. The automatic brake hold indicator light turns off. When the electronic parking brake is applied with the brake force maintained by the automatic brake hold function, the brake force of the automatic brake hold will be released. The automatic brake hold indicator light turns off.

NOTE:

- **When the vehicle stops in a slope, depress the brake pedal firmly until the automatic brake hold indicator light (green) illuminates.**
- **Under the following conditions, the electronic parking brake will automatically be applied and the brake force of the automatic brake hold will be released (the automatic brake hold indicator light turns off):**
 - **The braking force is applied by the automatic brake hold function for 3 minutes or longer.**
 - **The vehicle is in the P (Park) position.**

DRIVE MODE SELECTOR

- The electronic parking brake is applied manually.
- The driver's seat belt is unfastened.
- The driver's door is opened.
- The power switch is placed in the OFF position.
- A malfunction occurs in the automatic brake hold function.
- When the vehicle stops, but the brake force is not automatically applied, depress the brake pedal firmly until the automatic brake hold indicator light (green) illuminates.

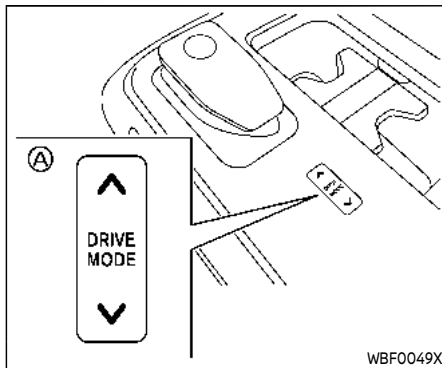

Drive Mode Selector

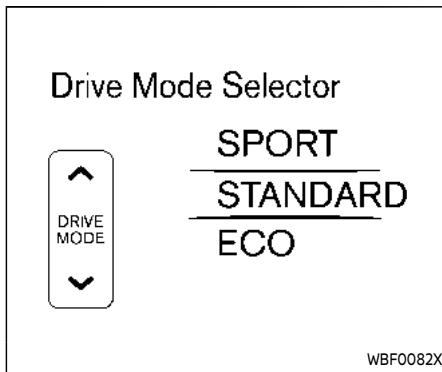

Vehicle information display (2WD models)

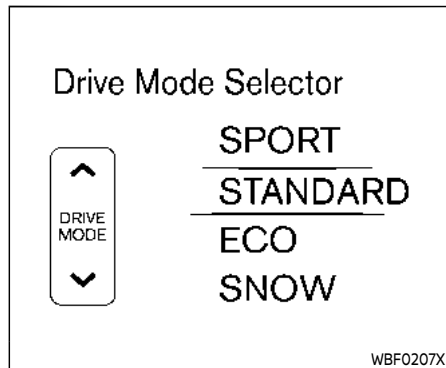

Vehicle information display (AWD models)

Multiple driving modes can be selected by using the Drive Mode Selector as below.

2WD models: SPORT, STANDARD and ECO

AWD models: SPORT, STANDARD, ECO and SNOW

To change the mode, push the upper side or lower side of the Drive Mode Selector .

NOTE:

When the Drive Mode Selector selects a mode, the mode may not switch immediately. This is not a malfunction.

The current mode is displayed in the vehicle information display. The mode list will appear in the vehicle information

display and you can select the mode.

NOTE:

The mode list will be turned off in approximately 5 seconds after the mode is selected.

You can also clear the message by pressing OK on the steering wheel switch.

If the driving mode cannot be switched using the Drive Mode Selector when the power switch is in the ON position, have the system checked. It is recommended you visit a NISSAN certified ARIYA dealer for this service.

NOTE:

The STANDARD mode will be selected first each time the power switch is placed in the ON position.



WARNING

- **Do not stare at the Drive Mode Selector or the display while driving so that full attention may be given to vehicle operation.**
- **Avoid abrupt acceleration, steering or sudden braking especially on slippery roads. Otherwise tire slip, skid or tail-swing occurs; this may cause an accident.**

STANDARD MODE

This is the standard mode that is most suitable for normal driving.

ECO MODE

Assists the driver's ECO-driving. The EV system and transmission points are adjusted for providing such a driving features as smooth starting or constant cruising.

NOTE:

Selecting the ECO mode will not necessarily improve energy economy as many driving factors influence its effectiveness.

Operation

Select the ECO mode using the Drive Mode Selector. The ECO indicator illuminates.

Tire Pres ECO advice

The "Tire Pres ECO advice" is a function to show an ECO advice message in the vehicle information display when low tire pressure is detected. To activate or deactivate this function, see "ECO Mode Setting" (P.2-28).

When the setting is ON, the ECO Drive Report display shows "Check Tire Pressures for Best Energy Economy". You can switch the display to the Tire Pressures

display by pushing the ◀ ▶ button on the steering wheel.

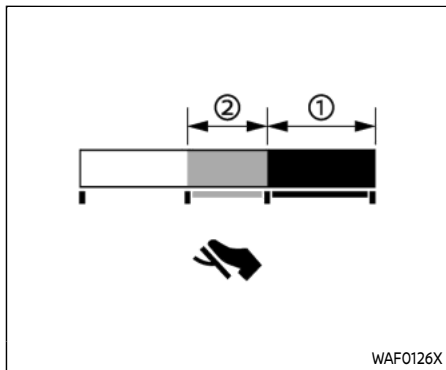

ECO Pedal Guide function

The ECO Pedal Guide display can be selected in the vehicle information display in the ECO mode. (See "4. ECO Pedal Guide" (P.2-45).) Use the ECO Pedal Guide function for improving energy economy.

When the ECO Pedal Guide bar is in the green range ①, it indicates that the vehicle is being driven within range of the super economy drive.

When the ECO Pedal Guide bar is in the light green range ②, it indicates that the vehicle is being driven within range of the economy drive.

If the ECO Pedal Guide bar is out of the

green range (① and ②), it indicates that the accelerator pedal is depressed over the range of economy drive.

The ECO Pedal Guide bar is not displayed when:

- The vehicle speed is less than approximately 2 MPH (4 km/h).
- The shift lever is in the P (Park), N (Neutral) or R (Reverse) position.

SPORT MODE

- Provides higher motor torque response for agile driveability and stronger regeneration brake for sporty drive by accelerator pedal only.
- The setting of the steering system is adjusted to moderately increase steering wheel effort for a sporty feel.

NOTE:









In the SPORT mode, energy economy may be reduced.











SNOW MODE (AWD models)

This mode makes it easier to start and drive on snowy roads and frozen roads.

DRIVER ASSISTANCE SYSTEMS

Each Driver Assistance system is designed to help the driver in different ways as they drive. The following Driver Assistance systems (if so equipped) are available on this vehicle:

Category	System	Symbol	System description (See the specified page for detailed information.)	Page
Forward Driving Aids	Automatic Emergency Braking (AEB) with Pedestrian Detection		Assists the driver with a warning and/or braking operation when there is a risk of a forward collision with the vehicle ahead in the traveling lane, or with a pedestrian.	5-120
	Intelligent Forward Collision Warning (I-FCW)		Helps alert the driver when there is a sudden braking of a second vehicle traveling in front of the vehicle ahead in the same lane.	5-130
Side Driving Aids (Lane and Blind Spot)	Lane Departure Warning (LDW)		Warns the driver that the vehicle is about to cross a lane marker with an indicator and a steering wheel vibration.	5-44
	Intelligent Lane Intervention (I-LI)		<ul style="list-style-type: none"> Warns the driver that the vehicle is about to cross a lane marker with an indicator and a steering wheel vibration. Assists the driver to return the vehicle to the center of the traveling lane. 	5-49
	Blind Spot Warning (BSW)		Warns the driver of a vehicle in an adjacent lane when changing lanes with an indicator.	5-55
	Intelligent Blind Spot Intervention (I-BSI)		<ul style="list-style-type: none"> Warns the driver of a vehicle in an adjacent lane when changing lanes. Assists the driver to return the vehicle to the center of the traveling lane. 	5-63
Rear Driving Aids	Rear Cross Traffic Alert (RCTA)		Assists the driver when backing out from a parking space by detecting other vehicles approaching from the right or left of the vehicle.	5-75
	Rear Automatic Braking (RAB)		Assists the driver when the vehicle is backing up and approaching stationary objects directly behind the vehicle by providing a warning and automatic braking if needed.	5-141
Parking Aids	RearView Monitor	-	Shows a rear view of the vehicle when the shift lever is placed in the R (Reverse) position.	4-3
	Intelligent Around View® Monitor	-	Assists the driver in parking situations by showing various views of the position of the vehicle in a split screen format.	4-11
	Moving Object Detection (MOD)	-	Informs the driver of moving objects near the vehicle in parking situations.	4-23
	Sonar system	-	Informs the driver with a visual and audible alert of stationary obstacles near the bumpers or the vehicle sides (flanks) (if so equipped).	5-160

Category	System	Symbol	System description (See the specified page for detailed information.)	Page
ProPILOT Assist	Intelligent Cruise Control (ICC)		<ul style="list-style-type: none"> Helps the driver maintain a selected distance from the vehicle ahead and can reduce the speed to match a slower vehicle ahead. Decelerates the vehicle to a standstill when a vehicle ahead slows to a stop. 	5-98
	Speed Limit Assist		Detects a change of the speed limit, indicates the detected speed limit and can apply it to the vehicle set speed automatically or manually. (A feature of ProPILOT Assist with Navi-link)	5-103
	Speed Adjust by Route		Adjusts the vehicle speed depending on curves, junctions and exits, using road information provided by the navigation system. (A feature of ProPILOT Assist with Navi-link)	5-105
	Steering Assist		<ul style="list-style-type: none"> Assists the driver to help keep the vehicle within the center of the traveling lane. Traffic and other conditions and laws permit, and it is safe to do so, driver's hands can be taken off the steering wheel. Always pay attention to the road and the operation of the vehicle. (A feature of ProPILOT Assist 2.0) 	5-106
	Lane Change Assist		Help the driver make a lane change when the turn signal is activated (A feature of ProPILOT Assist 2.0)	5-113
	Passing Assist		Help the driver make a lane change when a slower vehicle is detected ahead (A feature of ProPILOT Assist 2.0)	5-115
	Route Assist		Help the driver make a lane change when approaching the point where a lane change is necessary, according to the route set in the navigation system. (A feature of ProPILOT Assist 2.0)	5-118
Other Driving Aids	High beam assist		Switches the headlights to the low beam automatically when an oncoming vehicle or leading vehicle appears in front of your vehicle.	2-64
	Traffic Sign Recognition (TSR)		Provides the driver with information about the most recently detected speed limit.	5-40
	Driver Monitor	-	Monitors the driver's attention to the road ahead with a driver facing camera.	5-111
	Intelligent Driver Alertness (I-DA)		Helps alert the driver when a lack of attention or driving fatigue is detected.	5-139
	Hill Start Assist	-	Helps prevent the vehicle from rolling backwards in the time it takes the driver to release the brake pedal and apply the accelerator when the vehicle is stopped on a hill.	5-159

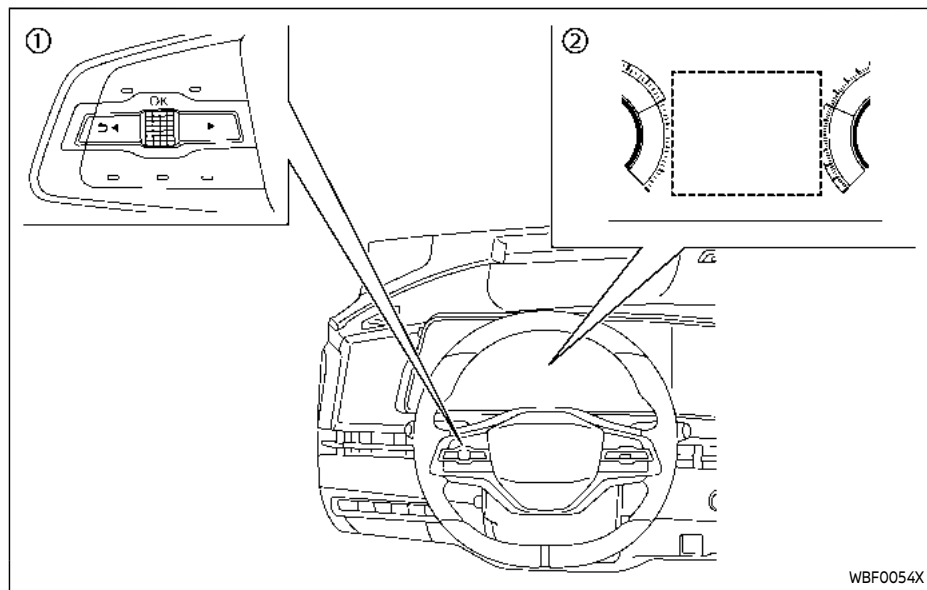

- ① Steering-wheel-mounted controls (left side)
- ② Vehicle information display

HOW TO ENABLE/DISABLE THE SYSTEMS

The following systems (if so equipped) can be enabled or disabled using the settings menu in the vehicle information display. Select each setting item using the scroll dial on the steering-wheel-

mounted controls.

- Automatic Emergency Braking (AEB) with Pedestrian Detection
- Intelligent Forward Collision Warning (I-FCW)
- Lane Departure Warning (LDW)
- Intelligent Lane Intervention (I-LI)*
- Blind Spot Warning (BSW)
- Intelligent Blind Spot Intervention (I-BSI)*
- Steering Assist
- Rear Cross Traffic Alert (RCTA)
- Rear Automatic Braking (RAB)
- Moving Object Detection (MOD)
- Sonar system
- Speed Limit Assist (ProPILOT Assist with Navi-link)
- Speed Adjust by Route (ProPILOT Assist with Navi-link)
- Traffic Sign Recognition (TSR)
- Intelligent Driver Alertness (I-DA)
- Lane Change Assist (ProPILOT Assist 2.0)
- Passing Assist (ProPILOT Assist 2.0)
- Route Assist (ProPILOT Assist 2.0)

*: To operate the I-LI and I-BSI systems, you need to push the ProPILOT Assist switch after enabling each system in the settings menu.

Driver Assistance display

The Driver Assistance display appears in the vehicle information display when selected using the scroll dial, or for a short period of time when the ProPILOT Assist switch is pushed.

The status of the following systems can be shown in each zone of the display.

Zone	Driving Aid
Forward	Automatic Emergency Braking (AEB) with Pedestrian Detection
	Intelligent Forward Collision Warning (I-FCW)
Lane	Lane Departure Warning (LDW)
	Intelligent Lane Intervention (I-LI)
Blind Spot	Blind Spot Warning (BSW)
	Intelligent Blind Spot Intervention (I-BSI)

- When any of the "Warning" systems are enabled, the "🔊" mark is shown in each zone.
- When any of the "Intervention" systems are enabled, the "🚫" mark is shown in each zone.
- When no system is enabled, "OFF" is shown in each zone.

The display changes as the following examples:

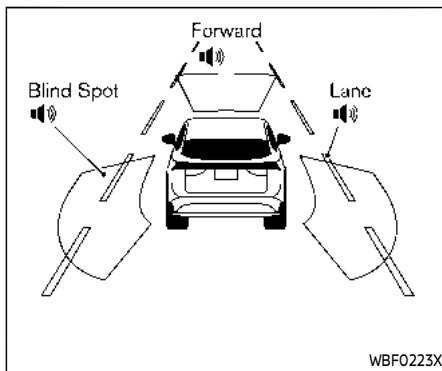

All: outline

Zone	Driving Aid	Status
Forward	Automatic Emergency Braking (AEB) with Pedestrian Detection	Enabled (outline)
	Intelligent Forward Collision Warning (I-FCW)	
Lane	Lane Departure Warning (LDW)	Enabled (outline)
	Intelligent Lane Intervention (I-LI)	Disabled
Blind Spot	Blind Spot Warning (BSW)	Enabled (outline)
	Intelligent Blind Spot Intervention (I-BSI)	Disabled

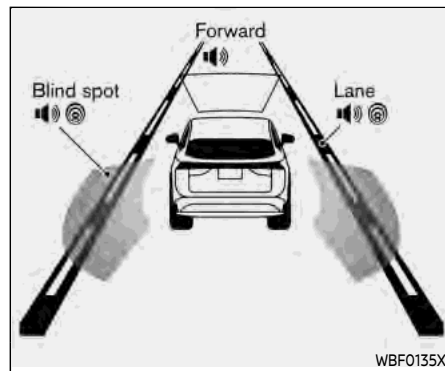

Forward: outline, Other: shaded

Zone	Driving Aid	Status
Forward	Automatic Emergency Braking (AEB) with Pedestrian Detection	Enabled (outline)
	Intelligent Forward Collision Warning (I-FCW)	
Lane	Lane Departure Warning (LDW)	Enabled
	Intelligent Lane Intervention (I-LI)	Enabled (shaded)
Blind Spot	Blind Spot Warning (BSW)	Enabled
	Intelligent Blind Spot Intervention (I-BSI)	Enabled (shaded)

DRIVER ASSISTANCE TROUBLESHOOTING GUIDE

Some of the Driver Assistance systems use the common parts (camera, radar, sonar, etc.) to function. When a pop-up warning message appears in the vehicle information display or the warning light flashes/illuminated, check the system conditions.

For system temporarily unavailable

It is important to ensure the radar sensors, cameras and sonar sensors are clean before each drive. Unclear or damaged cameras and sensors, as well as environmental conditions can affect system performance. See "Camera, radar and sonar locations" (P.5-39) for detailed locations.

Forward Driving Aids temporarily disabled Front Sensor blocked See Owner's Manual	<ul style="list-style-type: none">● AEB light will also flash● Condition A: Poor weather conditions including heavy rain, snow, fog, etc● Condition B: Front radar sensor is obstructed due to dirt, snow, ice, etc● Condition C: Roads with limited structures or buildings (barren)● Clean the front radar area of the vehicle to remove any obstruction● Systems will automatically resume once conditions no longer exist. Intervention systems will need to be reactivated.● Systems Affected: ICC, I-FCW and AEB with Pedestrian Detection● If ICC system is temporarily unavailable, the conventional (fixed speed) may still be used.
Unavailable - Side Radar Obstructed	<ul style="list-style-type: none">● Side radar sensor is obstructed due to dirt, snow, ice, etc● Clean the side radar area of the vehicle to remove any obstruction● Systems Affected: BSW, I-BSI and RCTA
Unavailable - High Cabin Temperature	<ul style="list-style-type: none">● Direct sunlight to camera or high cabin temperature● When the interior cabin temperature is reduced, systems will resume automatically. Intervention systems will need to be reactivated.● Systems Affected: LDW, I-LI, I-BSI, Steering Assist, AEB with Pedestrian Detection
Not Available - Front Camera Obstructed	<ul style="list-style-type: none">● Poor camera visibility caused by direct sunlight or camera obstruction due to fog, ice, or condensation in camera housing● Clean windshield glass around camera area using wipers and defrost function● Systems Affected: Steering Assist and AEB with Pedestrian Detection
Currently Unavailable	<ul style="list-style-type: none">● Condition A: VDC system is turned off● Condition B: SNOW Mode is selected (AWD models)● Ensure VDC is active and drive mode is not in SNOW mode● Systems Affected: I-LI, I-BSI, and ICC● If ICC system is temporarily unavailable, the conventional (fixed speed) may still be used.

Unavailable Slippery Road	<ul style="list-style-type: none"> ● Systems become unavailable because the road is slippery. ● Systems Affected: I-LI, I-BSI and ProPILOT Assist
Unavailable Seatbelt is Unfastened	<ul style="list-style-type: none"> ● ProPILOT Assist cannot be used when the driver's seat belt is not fastened. ● Fasten the driver's seat belt to use ProPILOT Assist.
Unavailable Adverse Weather	<ul style="list-style-type: none"> ● Steering Assist will be canceled. ● Condition A: When the wiper (HI) operates ● Condition B: When lane markers in the traveling lane cannot be correctly detected
Steering Assist Not Available Cannot Detect Lane	<ul style="list-style-type: none"> ● Steering Assist will be canceled when the lane markers in the traveling lane cannot be correctly detected. ● A snow rut, reflection of light on a rainy day or several unclear lane markers are present.
Unavailable Parking Brake is ON	<ul style="list-style-type: none"> ● ProPILOT Assist will be canceled when the electronic parking brake is applied. ● The system cannot be used when the electronic parking brake is activated.
Press brake pedal to prevent rolling	<ul style="list-style-type: none"> ● While the vehicle is stopped by ProPILOT Assist, the driver's door is opened but the electronic parking brake was not activated. ● Step on the brake pedal immediately.
AEB light illumination (no message)	<ul style="list-style-type: none"> ● VDC system is turned off. ● Turn back on VDC system ● System Affected: AEB with Pedestrian Detection
AEB Light flashing (no message)	<ul style="list-style-type: none"> ● Interference from an unknown radar source ● Camera high temperature ● Poor camera visibility due to dirt on the lens ● Systems will automatically resume once conditions no longer exist. Intervention systems will need to be reactivated. ● Systems Affected: ICC, I-FCW and AEB with Pedestrian Detection ● If ICC system is temporarily unavailable, the conventional (fixed speed) may still be used.
Rear Automatic Braking (RAB) light illumination (no message)	<ul style="list-style-type: none"> ● The shift lever is placed in the R position while VDC system is off. ● Turn back on VDC system.
Rear Automatic Braking (RAB) light flashing (no message)	<ul style="list-style-type: none"> ● Interference from an unknown radar source ● RAB system will automatically resume once conditions no longer exist.

For system malfunction

If any of the following malfunction warnings appear (orange), stop the vehicle in a safe location. Turn the EV system off, restart the EV system. If the warning message/light continue to illuminate, it may be a malfunction. It is recommended that you visit a NISSAN certified ARIYA dealer for service.

Malfunction - See Owner's Manual	● Systems Affected: TSR, LDW, I-LI, BSW, I-BSI, ProPILOT Assist, Steering Assist, I-DA and RCTA
Malfunction - See Owner's Manual and AEB light illumination	● Systems Affected: AEB with Pedestrian Detection and I-FCW
Malfunction - See Owner's Manual and Rear Automatic Braking (RAB) light illumination	● System Affected: Rear Automatic Braking (RAB)
Parking Sensor Error - See Owner's Manual	● Systems Affected: Sonar system

Camera, radar and sonar locations

The camera, radar and sonar that are used by each Driver Assistance systems are located on the front and rear of the vehicle. For the maintenance of each component, see "System maintenance" section in this Owner's Manual for each application system.

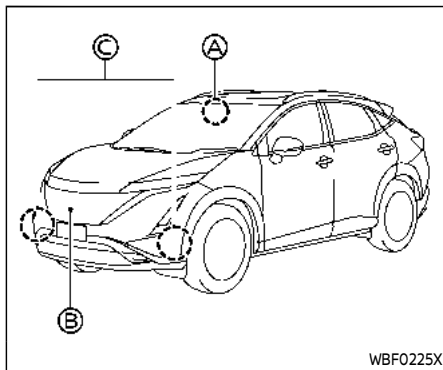

Vehicle front

- Ⓐ Front camera unit
 - Automatic Emergency Braking (AEB) with Pedestrian Detection
 - Lane Departure Warning (LDW)
 - Intelligent Lane Intervention (I-LI)
 - Intelligent Blind Spot Intervention (I-BSI)
 - Steering Assist (as part of ProPILOT Assist Systems)
 - High beam assist
 - Traffic Sign Recognition (TSR)
- Ⓑ Front radar sensor
 - Automatic Emergency Braking (AEB) with Pedestrian Detection
 - Intelligent Forward Collision Warning (I-

FCW)

– Intelligent Cruise Control (ICC) (as part of ProPILOT Assist Systems)

Ⓒ

Side radar sensor

– ProPILOT Assist 2.0

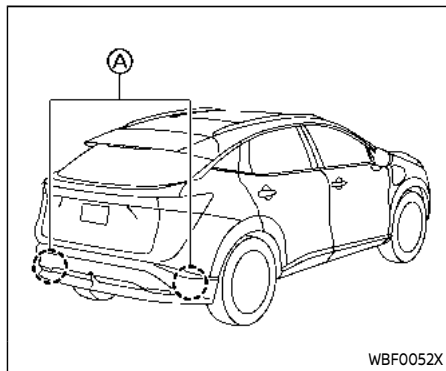

WBF0052X

Vehicle rear

- Ⓐ Side radar sensor
 - Blind Spot Warning (BSW)
 - Intelligent Blind Spot Intervention (I-BSI)
 - Rear Cross Traffic Alert (RCTA)

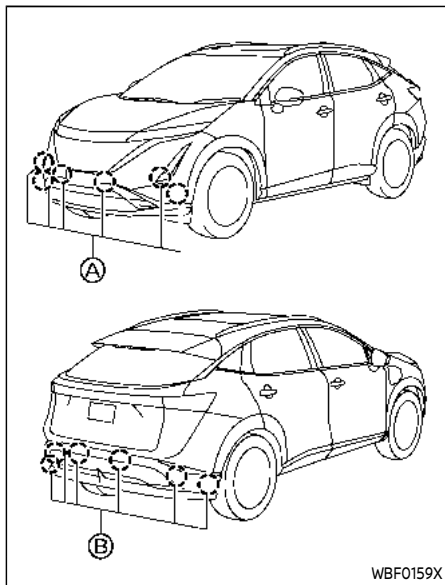

WBF0159X

Sonar

- Ⓐ Front and side (if so equipped) sonar sensors
 - Sonar system
- Ⓑ Rear and side (if so equipped) sonar sensors
 - Rear Automatic Braking (RAB)
 - Sonar system

TRAFFIC SIGN RECOGNITION (TSR)

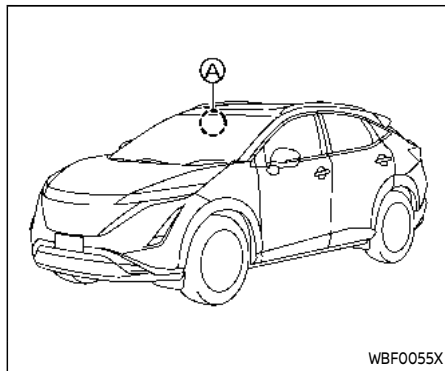

WBF0055X

The Traffic Sign Recognition (TSR) system provides the driver with information about the most recently detected speed limit. The system captures the road sign information with the multi-sensing front camera unit Ⓐ located on the windshield in front of the inside mirror and displays the detected signs in the vehicle information display. The speed limit displayed is based on a combination of navigation system data and live camera recognition. TSR information is shown in the vehicle information display and in the Head Up Display (HUD) (if so equipped). (See "Head Up Display (HUD)" (P.2-51).)

WARNING

The TSR system is only intended to be a support device to help provide the driver with information. It is not a replacement for the driver's attention to traffic conditions or responsibility to drive safely. It cannot prevent accidents due to carelessness. It is the driver's responsibility to stay alert and drive safely at all times.

SYSTEM OPERATION

The TSR system displays the following types of road sign:

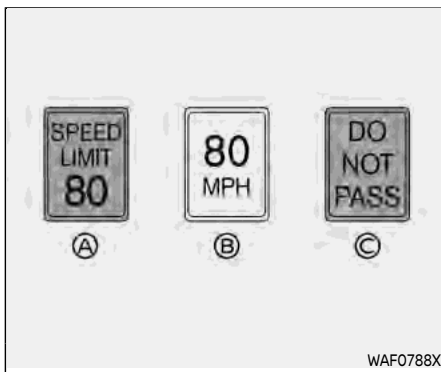

Ⓐ Latest detected speed limit

- Ⓑ Reduce speed limit caution
- Ⓒ No passing zone

CAUTION

- The TSR system is intended as an aid to careful driving. It is the driver's responsibility to stay alert, drive safely, and observe all road regulations that currently apply, including looking out for road signs.
- The TSR system may not function properly under all conditions. Below are some examples:
 - When the road sign is not clearly visible, for example, due to damage or weather conditions.
 - When rain, snow or dirt adheres to the windshield in front of the multi-sensing front camera unit.
 - When the headlights are not bright, for example, due to dirt on the lens or if the aiming is not adjusted properly.
 - When strong light enters the camera unit. (For example, the light directly shines on the

front of the vehicle at sunrise or sunset.)

- When a sudden change in brightness occurs. (For example, when the vehicle enters or exits a tunnel or under a bridge.)
- In areas not covered by the navigation system.
- If there are deviations in relation to the navigation, for example due to changes in the road routing.
- When overtaking buses or trucks with speed stickers.
- When the data from the navigation system is not up-to-date or is unavailable.
- The TSR system may display a traffic sign, though there is no traffic sign in front of the vehicle. It may display a different speed limit from that for a passenger vehicle. (The maximum speed limit sign may show a higher or lower number than the actual maximum speed, for example, when detecting a speed limit sign for truck, advisory sign, different speed limit sign between daytime

and nighttime, or speed limit sign written in different unit near the border, etc.)

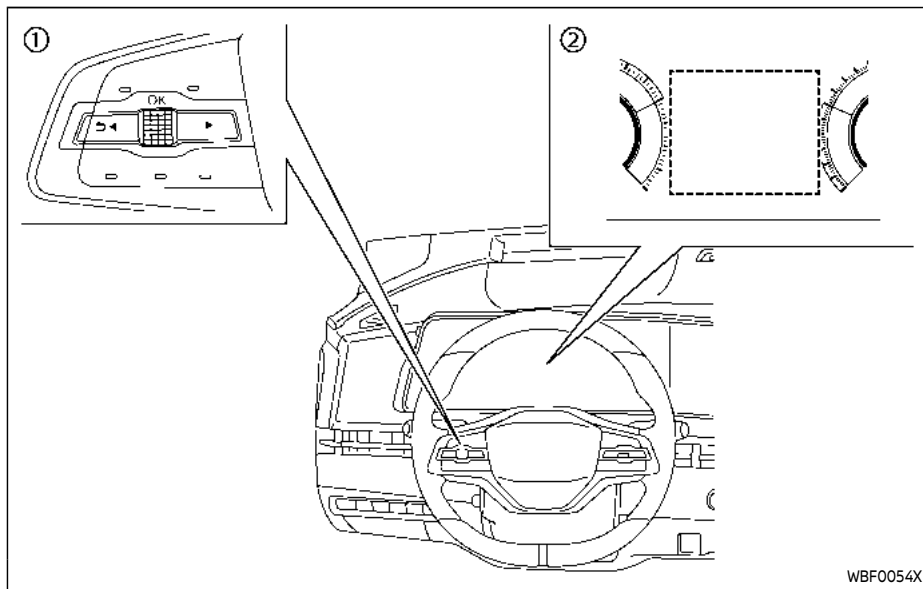

- ① Steering-wheel-mounted controls (left side)
- ② Vehicle information display

HOW TO ENABLE/DISABLE THE TSR SYSTEM (if so equipped)

Perform the following steps to enable or disable the TSR system:

1. Push the ◀ ▶ button until "Settings" appears in the vehicle information display and then push the scroll

dial. Use the scroll dial to select "Driver Assistance". Then push the scroll dial.

2. Select "Speed Limit Sign" and push the scroll dial to turn the system on or off.

SYSTEM TEMPORARILY UNAVAILABLE

If the vehicle is parked in direct sunlight under high temperature conditions (over approximately 104°F (40°C) and then started, the TSR system may be deactivated automatically.

Action to take:

When the interior temperature is reduced, the TSR system will resume operating automatically.

See "Driver assistance troubleshooting guide" (P.5-36).

SYSTEM MALFUNCTION

If the TSR system malfunctions it will be turned off automatically and the TSR "Malfunction See Owner's Manual" warning message will appear in the vehicle information display.

Action to take

If the warning message appears, pull off the road at a safe location and stop the vehicle. Turn the EV system off and restart the EV system. If the warning message continues to appear, have the system checked. It is recommended that

LANE DEPARTURE WARNING (LDW)

you visit a NISSAN certified ARIYA dealer.

SYSTEM MAINTENANCE

The TSR system uses the same multi-sensing front camera unit that is used by the Lane Departure Warning (LDW) system, located in front of the inside mirror. For maintenance of the camera, see "System maintenance" (P.5-48).



WARNING

Failure to follow the warnings and instructions for proper use of the LDW system could result in serious injury or death.

- **This system is only a warning device to inform the driver of a potential unintended lane departure. It will not steer the vehicle or prevent loss of control. It is the driver's responsibility to stay alert, drive safely, keep the vehicle in the traveling lane, and be in control of the vehicle at all times.**

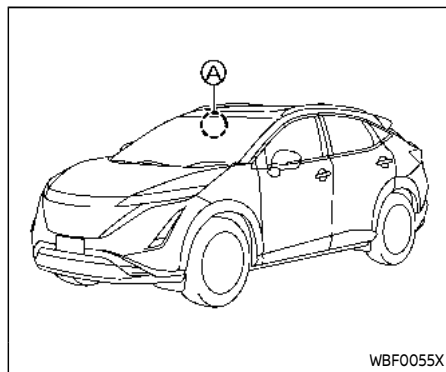

The LDW system will operate when the vehicle is driven at speeds of approximately 37 - 125 MPH (60 - 200 km/h), and the lane markings are clearly visible on the road.

The LDW system monitors the lane markers on the traveling lane using the camera unit (A) located above the inside mirror.

The LDW system warns the driver that the vehicle is beginning to leave the driving lane with an indicator and a steering wheel vibration. (See "LDW system operation" (P.5-45).)

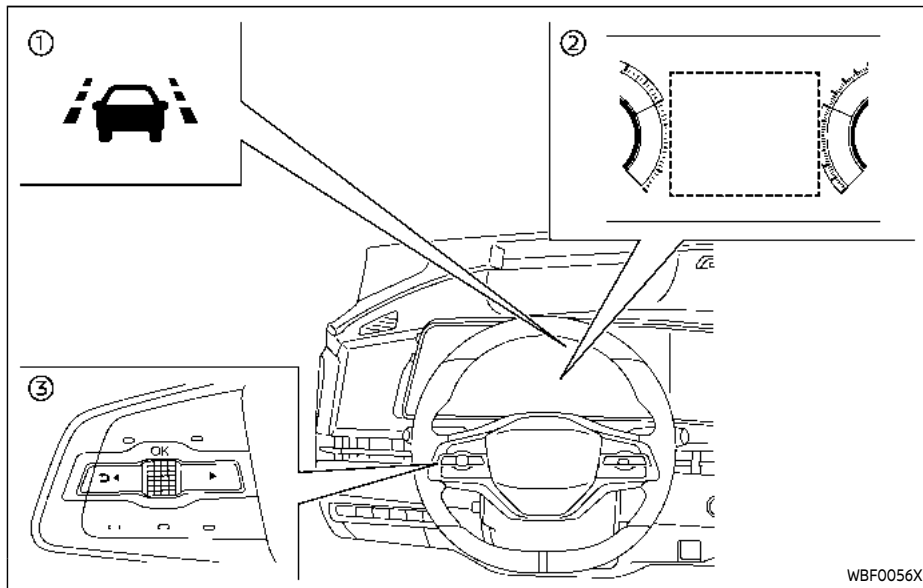

- ① LDW indicator (on the vehicle information display)
- ② Vehicle information display
- ③ Steering-wheel-mounted controls (left side)

LDW SYSTEM OPERATION

The LDW system provides a lane departure warning function when the vehicle is driven at speeds of approximately 37 - 125 MPH (60 - 200 km/h) and the lane markings are clear. When the vehicle approaches either the left or the right

side of the traveling lane, the steering wheel will vibrate and the LDW indicator on the vehicle information display will blink to alert the driver.

The warning function will stop when the vehicle returns inside of the lane markers.

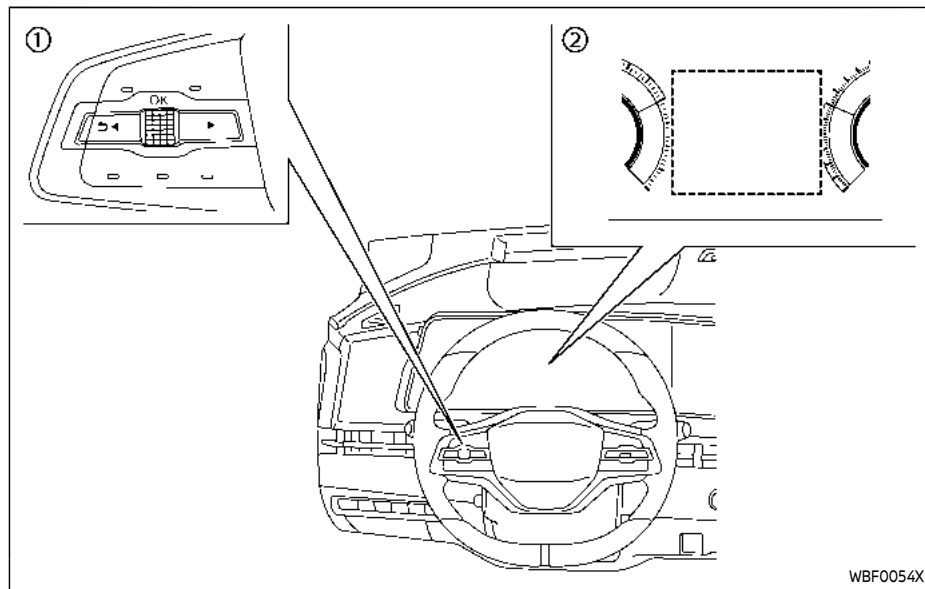

- ① Steering-wheel-mounted controls (left side)
- ② Vehicle information display

HOW TO ENABLE/DISABLE THE LDW SYSTEM

Perform the following steps to enable or disable the LDW system.

1. Push the ◀ ▶ button until “Settings” appears in the vehicle information display and then push the scroll

dial. Use the scroll dial to select “Driver Assistance”. Then push the scroll dial.

2. Select “Lane Assist” and push the scroll dial.
3. Select “Warning” and push the scroll dial.

NOTE:

If you disable the LDW system, the system will remain disabled the next time you start the vehicle’s EV system.

LDW SYSTEM LIMITATIONS

WARNING

Listed below are the system limitations for the LDW system. Failure to follow the warnings and instructions for proper use of the LDW system could result in serious injury or death.

- The system will not operate at speeds below approximately 37 MPH (60 km/h) or if it cannot detect lane markers.
- Do not use the LDW system under the following conditions as it may not function properly:
 - During bad weather (rain, fog, snow, etc.).

- When driving on slippery roads, such as on ice or snow.
- When driving on winding or uneven roads.
- When there is a lane closure due to road repairs.
- When driving in a makeshift or temporary lane.
- When driving on roads where the lane width is too narrow.
- When driving without normal tire conditions (for example, tire wear, low tire pressure, installation of tire chains or non-standard wheels).
- When the vehicle is equipped with non-original brake parts or suspension parts.
- When towing a trailer or other vehicle (AWD models).
- The system may not function properly under the following conditions:
 - On roads where there are multiple parallel lane markers; lane markers that are faded or not painted clearly; yellow painted lane markers; non-standard lane markers; or

lane markers covered with water, dirt, snow, etc.

- On roads where discontinued lane markers are still detectable.
- On roads where there are sharp curves.
- On roads where there are sharply contrasting objects, such as shadows, snow, water, wheel ruts, seams or lines remaining after road repairs. (The LDW system could detect these items as lane markers.)
- On roads where the traveling lane merges or separates.
- When the vehicle's traveling direction does not align with the lane marker.
- When traveling close to the vehicle in front of you, which obstructs the lane camera unit detection range.
- When rain, snow, dirt or object adheres to the windshield in front of the lane camera unit.
- When the headlights are not bright due to dirt on the lens

or if the aiming is not adjusted properly.

- When strong light enters the lane camera unit. (For example, the light directly shines on the front of the vehicle at sunrise or sunset.)
- When a sudden change in brightness occurs. (For example, when the vehicle enters or exits a tunnel or under a bridge.)
- Steering wheel vibration may not be felt depending on the road surface conditions.

SYSTEM TEMPORARILY UNAVAILABLE

Condition A:

If the vehicle is parked in direct sunlight under high temperature conditions (over approximately 104°F (40°C)) and then started, the LDW system may be deactivated automatically and the following message will appear in the vehicle information display.

- "Unavailable Camera Temperature High"

When the interior temperature is reduced, the LDW system will resume operating

automatically.

Condition B:

The warning function of the LDW system is not designed to work under the following conditions:

- When you operate the lane change signal and change traveling lanes in the direction of the signal. (The LDW system will become operable again approximately 2 seconds after the lane change signal is turned off.)
- When the vehicle speed lowers to less than approximately 37 MPH (60 km/h).

Action to take:

After the above conditions have finished and the necessary operating conditions are satisfied, the LDW system will resume.

See "Driver assistance troubleshooting guide" (P.5-36).

SYSTEM MALFUNCTION

If the LDW system malfunctions, it will cancel automatically and "Malfunction See Owner's Manual" warning message will appear in the vehicle information display. If the warning message appears, pull off the road to a safe location and stop the vehicle. Place the power switch in the OFF position and restart the EV system. If the warning message continues to appear, have the system

checked. It is recommended that you visit a NISSAN certified ARIYA dealer for this service.

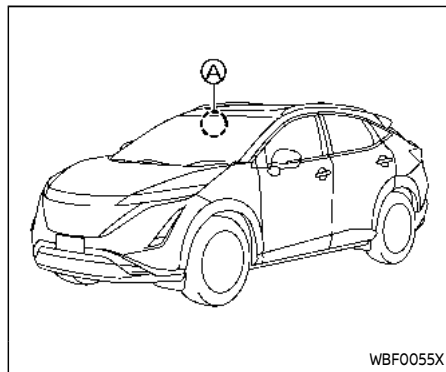

WBF0055X

SYSTEM MAINTENANCE

The lane camera unit (A) for the LDW system is located above the inside mirror.

To keep the proper operation of the LDW system and prevent a system malfunction, be sure to observe the following:

- Always keep the windshield clean.
- Do not attach a sticker (including transparent material) or install an accessory near the camera unit.
- Do not place reflective materials, such as white paper or a mirror, on the instrument panel. The reflection of sunlight may adversely affect the camera unit's capability of detecting the lane markers.

INTELLIGENT LANE INTERVENTION (I-LI)

- Do not strike or damage the areas around the camera unit. Do not touch the camera lens or remove the screw located on the camera unit. If the camera unit is damaged due to an accident, it is recommended that you visit a NISSAN certified ARIYA dealer.



WARNING

Failure to follow the warnings and instructions for proper use of the I-LI system could result in serious injury or death.

- **The I-LI system will not steer the vehicle or prevent loss of control. It is the driver's responsibility to stay alert, drive safely, keep the vehicle in the traveling lane, and be in control of the vehicle at all times.**
- **The I-LI system is primarily intended for use on well-developed freeways or highways. It may not detect the lane markers in certain road, weather, or driving conditions.**

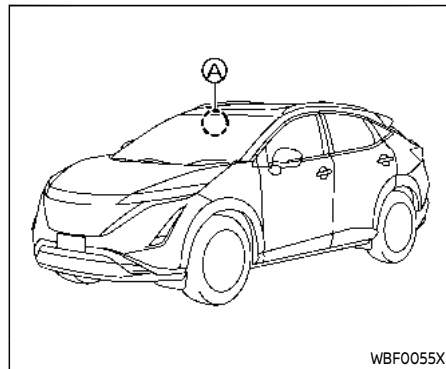

WBF0055X

The I-LI system must be turned on with the ProPILOT Assist switch on the steering wheel, every time the power switch is placed in the ON position.

The I-LI system will operate when the vehicle is driven at speeds of approximately 37 - 125 MPH (60 - 200 km/h), and only when the lane markings are clearly visible on the road. The I-LI system warns the driver when the vehicle has left the center of the traveling lane with an indicator and steering wheel vibration. The system helps assist the driver to return the vehicle to the center of the traveling lane by applying the brakes to the left or right wheels individually (for a short period of time).

The I-LI system monitors the lane markers on the traveling lane using the camera unit ④ located above the inside mirror.

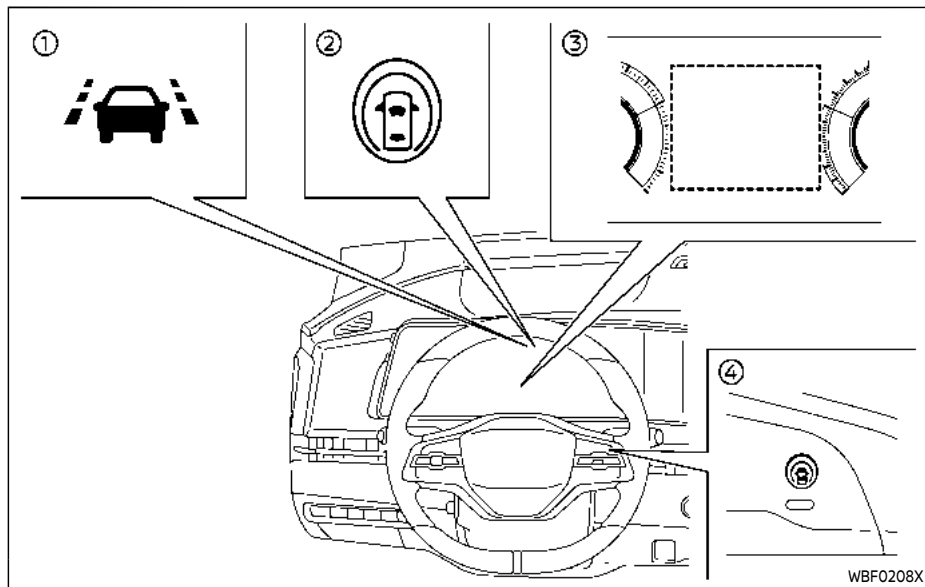

Example

- ① I-LI indicator (on the vehicle information display)
- ② I-LI ON indicator (on the vehicle information display)
- ③ Vehicle information display
- ④ ProPILOT Assist switch (The design varies depending on the models.)

I-LI SYSTEM OPERATION

The I-LI system operates when the vehicle is driven at speeds of approximately 37 – 125 MPH (60 – 200 km/h) and when the lane markings are clear. When the vehicle approaches either the left or the right side of the traveling lane, steering wheel

will vibrate and the I-LI indicator (orange) on the vehicle information display will blink to alert the driver. Then, the I-LI system will automatically apply the brakes for a short period of time to help assist the driver to return the vehicle to the center of the traveling lane.

To turn on the I-LI system, push the ProPILOT Assist switch on the steering wheel after starting the EV system. The I-LI ON indicator on the vehicle information display will illuminate. Push the ProPILOT Assist switch again to turn off the I-LI system. The I-LI ON indicator will turn off.

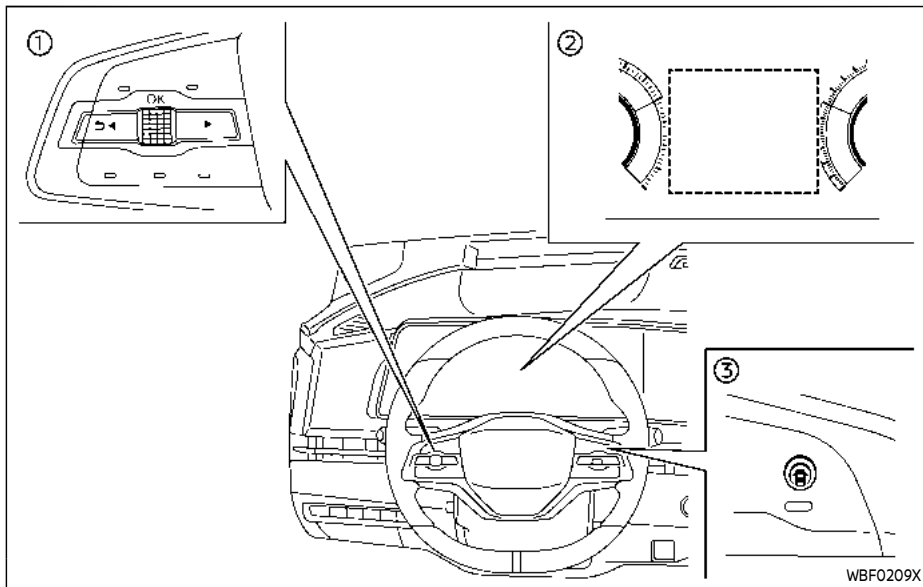

- Example**
- ① Steering-wheel-mounted control (left side)
 - ② Vehicle information display
 - ③ ProPILOT Assist switch (The design varies depending on the models.)

HOW TO ENABLE/DISABLE THE I-LI SYSTEM

Perform the following steps to enable or disable the I-LI system.

1. Push the ◀ ▶ button until "Settings" appears in the vehicle information display and then push the scroll dial.

Use the scroll dial to select "Driver Assistance." Then push the scroll dial.

2. Select "Lane Assist" and push the scroll dial.
3. Select "Intervention" and push the scroll dial.
4. Push the ProPILOT Assist switch to turn the system on or off.

NOTE:

Turning on the ProPILOT Assist system will turn on the I-LI and I-BSI systems at the same time. If the I-LI system is disabled in the settings menu, the I-LI will automatically be turned on when the Steering Assist system is active. (See "ProPILOT Assist Systems" (P.5-82).)

I-LI SYSTEM LIMITATIONS



WARNING

Listed below are the system limitations for the I-LI system. Failure to follow the warnings and instructions for proper use of the I-LI system could result in serious injury or death.

- The I-LI system may activate if you change lanes without first activating your turn signal or, for

example, if a construction zone directs traffic to cross an existing lane marker. If this occurs you may need to apply corrective steering to complete your lane change.

- Because the I-LI may not activate under the road, weather, and lane marker conditions described in this section, it may not activate every time your vehicle begins to leave its lane and you will need to apply corrective steering.
- The I-LI system will not operate at speeds below approximately 37 MPH (60 km/h) or if it cannot detect lane markers.
- When the I-LI system is operating, avoid excessive or sudden steering maneuvers. Otherwise, you could lose control of the vehicle.
- Do not use the I-LI system under the following conditions as it may not function properly:
 - During bad weather (rain, fog, snow, etc.).
 - When driving on slippery roads, such as on ice or snow.
 - When driving on winding or uneven roads.

- When there is a lane closure due to road repairs.
- When driving in a makeshift or temporary lane.
- When driving on roads where the lane width is too narrow.
- When driving without normal tire conditions (for example, tire wear, low tire pressure, installation of tire chains or non-standard wheels).
- When the vehicle is equipped with non-original brake parts or suspension parts.
- When towing a trailer or other vehicle (AWD models).
- On roads where there are multiple parallel lane markers; lane markers that are faded or not painted clearly; yellow painted lane markers; non-standard lane markers; or lane markers covered with water, dirt, snow, etc.
- On roads where discontinued lane markers are still detectable.
- On roads where there are sharp curves.

- On roads where there are sharply contrasting objects, such as shadows, snow, water, wheel ruts, seams or lines remaining after road repairs. (The I-LI system could detect these items as lane markers.)
- On roads where the traveling lane merges or separates.
- When the vehicle's traveling direction does not align with the lane marker.
- When traveling close to the vehicle in front of you, which obstructs the lane camera unit detection range.
- When rain, snow or dirt adheres to the windshield in front of the lane camera unit.
- When the headlights are not bright due to dirt on the lens or if the aiming is not adjusted properly.
- When strong light enters the lane camera unit. (For example, the light directly shines on the front of the vehicle at sunrise or sunset.)

– When a sudden change in brightness occurs. (For example, when the vehicle enters or exits a tunnel or under a bridge.)

- Steering wheel vibration may not be felt depending on the road surface conditions.

While the I-LI system is operating, you may hear a sound of brake operation. This is normal and indicates that the I-LI system is operating properly.

SYSTEM TEMPORARILY UNAVAILABLE

Condition A:

The warning and assist functions of the I-LI system are not designed to work under the following conditions:

- When you operate the lane change signal and change the traveling lanes in the direction of the signal. (The I-LI system will be deactivated for approximately 2 seconds after the lane change signal is turned off.)
- When the vehicle speed lowers to less than approximately 37 MPH (60 km/h).

Action to take:

After the above conditions have finished and the necessary operating conditions

are satisfied, the warning and assist functions will resume.

Condition B:

The assist function of the I-LI system is not designed to work under the following conditions (warning is still functional):

- When the brake pedal is depressed.
- When the steering wheel is turned as far as necessary for the vehicle to change lanes.
- When the vehicle is accelerated during the I-LI system operation.
- When the Intelligent Cruise Control (ICC) approach warning occurs.
- When the hazard warning flashers are operated.
- When driving on a curve at high speed.

Action to take:

After the above conditions have finished and the necessary operating conditions are satisfied, the I-LI system application of the brakes will resume.

Condition C:

If the following message appears in the vehicle information display, a chime will sound and the I-LI system will be turned off automatically.

- "Unavailable Slippery Road":
 - When the Vehicle Dynamic Control (VDC) system (except Traction Control System (TCS) function) or ABS operates.
- "Currently Unavailable":
 - When the Vehicle Dynamic Control (VDC) system is turned off.
 - When the SNOW mode is selected (AWD models).

Action to take:

When the above conditions no longer exist, turn off the I-LI system. Push the ProPILOT Assist switch again to turn the I-LI system back on.

Temporary disabled status at high temperature:

If the vehicle is parked in direct sunlight under high temperature conditions (over approximately 104°F (40°C)) and then the I-LI system is turned on, the I-LI system may be deactivated automatically, a chime sounds and the following message will appear on the vehicle information display:

- "Unavailable Camera Temperature High"

When the interior temperature is reduced, turn off the I-LI system. Push the ProPILOT Assist switch again to turn the I-LI system back on.

See "Driver assistance troubleshooting guide" (P.5-36).

SYSTEM MALFUNCTION

If the I-LI system malfunctions, it will cancel automatically. The I-LI indicator (orange) will illuminate, a chime will sound and the "Malfunction See Owner's Manual" warning message will appear in the vehicle information display.

If the I-LI indicator (orange) illuminates, pull off the road to a safe location. Turn the EV system off and restart the EV system. If the I-LI indicator (orange) continues to illuminate, have the I-LI system checked. It is recommended that you visit a NISSAN certified ARIYA dealer for this service.

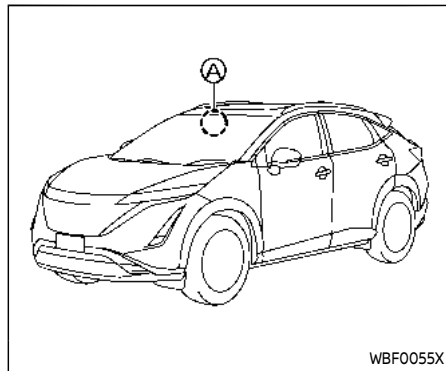

SYSTEM MAINTENANCE

The lane camera unit (A) for the I-LI system is located above the inside mirror. To keep the proper operation of the I-LI system and prevent a system malfunction, be sure to observe the following:

- Always keep the windshield clean.
- Do not attach a sticker (including transparent material) or install an accessory near the camera unit.
- Do not place reflective materials, such as white paper or a mirror, on the instrument panel. The reflection of sunlight may adversely affect the camera unit's capability of detecting the lane markers.

BLIND SPOT WARNING (BSW)

- Do not strike or damage the areas around the camera unit. Do not touch the camera lens or remove the screw located on the camera unit. If the camera unit is damaged due to an accident, it is recommended that you visit a NISSAN certified ARIYA dealer.





WARNING

Failure to follow the warnings and instructions for proper use of the BSW system could result in serious injury or death.

- The BSW system is not a replacement for proper driving procedure and is not designed to prevent contact with vehicles or objects. When changing lanes, always use the side and rear mirrors and turn and look in the direction your vehicle will move to ensure it is safe to change lanes. Never rely solely on the BSW system.

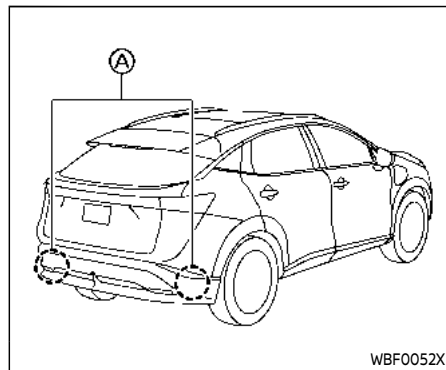
The BSW system helps alert the driver of other vehicles in adjacent lanes when changing lanes.



The BSW system uses radar sensors  installed near the rear bumper to detect other vehicles in an adjacent lane.

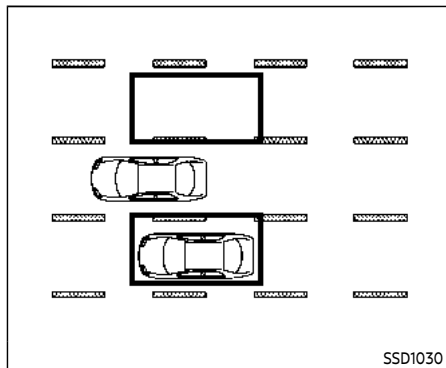

Detection zone

The radar sensors can detect vehicles on either side of your vehicle within the detection zone shown as illustrated. This detection zone starts from the outside mirror of your vehicle and extends approximately 10 ft (3.0 m) behind the rear bumper, and approximately 10 ft (3.0 m) sideways.

When the turn signal is activated, the detection zone may extend more than approximately 10 ft (3.0 m).

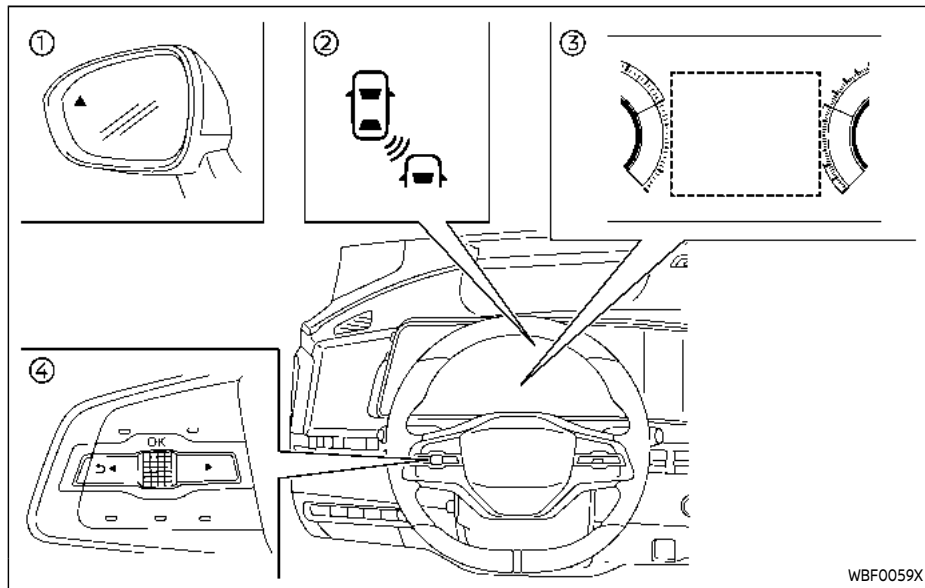

- ① Side indicator light
- ② BSW indicator (on the vehicle information display)
- ③ Vehicle information display
- ④ Steering-wheel-mounted controls (left side)

BSW SYSTEM OPERATION

The BSW system operates above approximately 20 MPH (32 km/h).

If the radar sensors detect a vehicle in the detection zone, the side indicator light illuminates.

If the turn signal is then activated, the

system chimes (twice) and the side indicator light and BSW indicator flash. The side indicator light and BSW indicator continue to flash until the detected vehicle leaves the detection zone.

The side indicator light illuminates for a few seconds when the power switch is placed in the ON position.

The brightness of the side indicator light is adjusted automatically depending on the brightness of the ambient light.

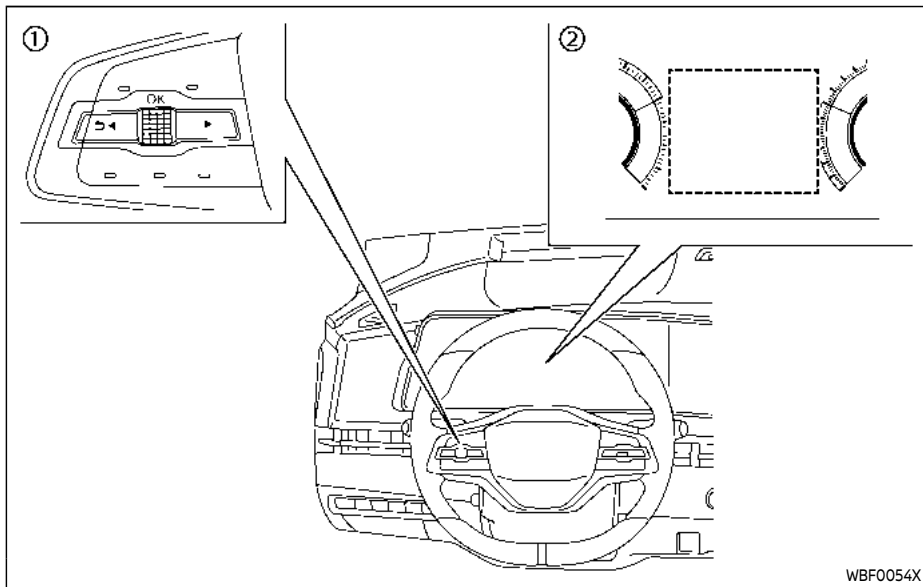

- ① Steering-wheel-mounted controls (left side)
- ② Vehicle information display

HOW TO ENABLE/DISABLE THE BSW SYSTEM

Perform the following steps to enable or disable the BSW system.

1. Push the ◀ ▶ button until "Settings" appears in the vehicle information display and then push the scroll

dial. Use the scroll dial to select "Driver Assistance". Then push the scroll dial.

2. Select "Blind Spot Assist" and push the scroll dial.
3. Select "Warning" and push the scroll dial.

NOTE:

The system will retain current settings in the vehicle information display even if the EV system is restarted.

BSW SYSTEM LIMITATIONS



WARNING

Listed below are the system limitations for the BSW system. Failure to operate the vehicle in accordance with these system limitations could result in serious injury or death.

- The BSW system cannot detect all vehicles under all conditions.
- The radar sensors may not be able to detect and activate BSW when certain objects are present such as:
 - Pedestrians, bicycles, animals.
 - Vehicles such as motorcycles, low height vehicles, or high ground clearance vehicles.

- Oncoming vehicles.
 - Vehicles remaining in the detection zone when you accelerate from a stop.
 - A vehicle merging into an adjacent lane at a speed approximately the same as your vehicle.
 - A vehicle approaching rapidly from behind.
 - A vehicle which your vehicle overtakes rapidly.
 - A vehicle that passes through the detection zone quickly.
 - When overtaking several vehicles in a row, the vehicles after the first vehicle may not be detected if they are traveling close together.
- The radar sensor's detection zone is designed based on a standard lane width. When driving in a wider lane, the radar sensors may not detect vehicles in an adjacent lane. When driving in a narrow lane, the radar sensors may detect vehicles driving two lanes away.

- The radar sensors are designed to ignore most stationary objects, however objects such as guardrails, walls, foliage and parked vehicles may occasionally be detected. This is a normal operation condition.
- The following conditions may reduce the ability of the radar to detect other vehicles:
 - Severe weather
 - Road spray
 - Ice/frost/dirt build-up on the vehicle
- Do not attach stickers (including transparent material), install accessories or apply additional paint near the radar sensors. These conditions may reduce the ability of the radar to detect other vehicles.
- Excessive noise (for example, audio system volume, open vehicle window) will interfere with the chime sound, and it may not be heard.

BSW DRIVING SITUATIONS

Indicator on



Indicator off



Indicator flashing

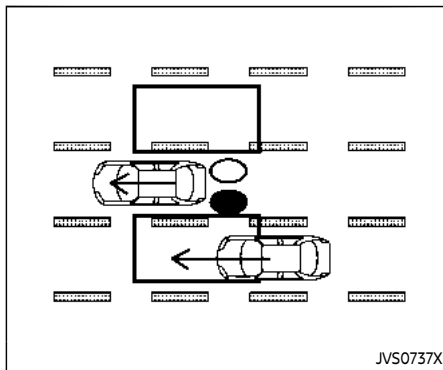

Illustration 1 – Approaching from behind

Another vehicle approaching from behind

Illustration 1: The side indicator light illuminates if a vehicle enters the detection zone from behind in an adjacent lane.

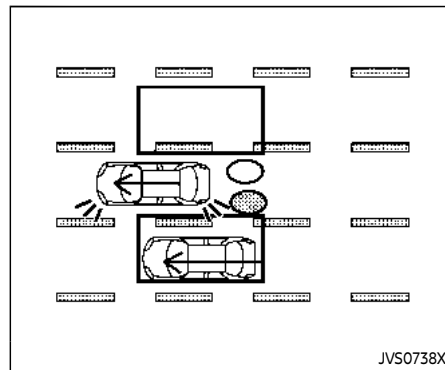

Illustration 2 – Approaching from behind

Illustration 2: If the driver activates the turn signal while another vehicle is in the detection zone, then the system chimes (twice) and the side indicator light and BSW indicator flash.

NOTE:

- The radar sensors may not detect vehicles which are approaching rapidly from behind.
- If the driver activates the turn signal before a vehicle enters the detection zone, the side indicator light and BSW indicator will flash but no chime will sound when the other vehicle is detected.

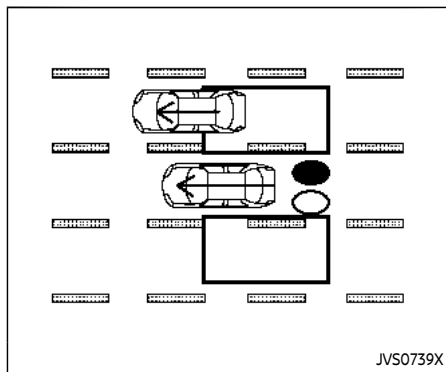

Illustration 3 - Overtaking another vehicle

Overtaking another vehicle

Illustration 3: The side indicator light illuminates if you overtake a vehicle and that vehicle stays in the detection zone for approximately 2 seconds.

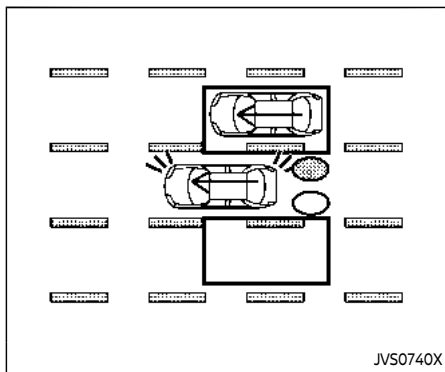

Illustration 4 - Overtaking another vehicle

Illustration 4: If the driver activates the turn signal while another vehicle is in the detection zone, then the system chimes (twice) and the side indicator light and BSW indicator flash.

NOTE:

- When overtaking several vehicles in a row, the vehicles after the first vehicle may not be detected if they are traveling close together.
- The radar sensors may not detect slower moving vehicles if they are passed quickly.
- If the driver activates the turn signal before a vehicle enters the detection zone, the side indicator light and

BSW indicator will flash but no chime will sound when the other vehicle is detected.

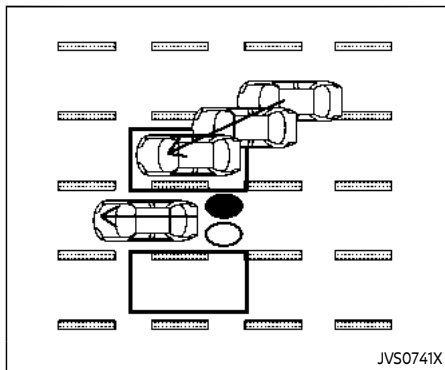

Illustration 5 – Entering from the side

Entering from the side

Illustration 5: The side indicator light illuminates if a vehicle enters the detection zone from either side.

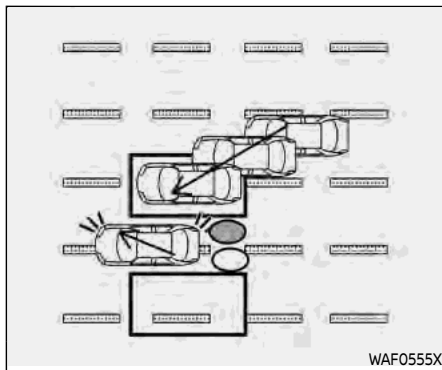

Illustration 6 – Entering from the side

Illustration 6: If the driver activates the turn signal while another vehicle is in the detection zone, then the system chimes (twice) and the side indicator light and BSW indicator flash.

NOTE:

- **The radar sensors may not detect a vehicle which is traveling at about the same speed as your vehicle when it enters the detection zone.**
- **If the driver activates the turn signal before a vehicle enters the detection zone, the side indicator light and BSW indicator will flash but no chime will sound when the other vehicle is detected.**

SYSTEM TEMPORARILY UNAVAILABLE

When radar blockage is detected, the BSW system will be turned off automatically and the "Unavailable Side Radar Obstruction" warning message will appear in the vehicle information display.

The system is not available until the conditions no longer exist.

The radar sensors may be blocked by temporary ambient conditions such as splashing water, mist or fog. The blocked condition may also be caused by objects such as ice, frost or dirt obstructing the radar sensors.

NOTE:

If the BSW system stops working, the Intelligent Blind Spot Intervention (I-BSI) and the Rear Cross Traffic Alert (RCTA) systems will also stop working.

Action to take:

When the above conditions no longer exist, the system will resume automatically.

See "Driver assistance troubleshooting guide" (P.5-36).

SYSTEM MALFUNCTION

When the BSW system malfunctions, it will be turned off automatically and the “Malfunction See Owner’s Manual” warning message will appear in the vehicle information display.

NOTE:

If the BSW system stops working, the Intelligent Blind Spot Intervention (I-BSI) and Rear Cross Traffic Alert (RCTA) systems will also stop working.

Action to take:

Stop the vehicle in a safe location, turn the EV system off and restart the EV system. If the message continues to appear, have the BSW system checked. It is recommended that you visit a NISSAN certified ARIYA dealer for this service.

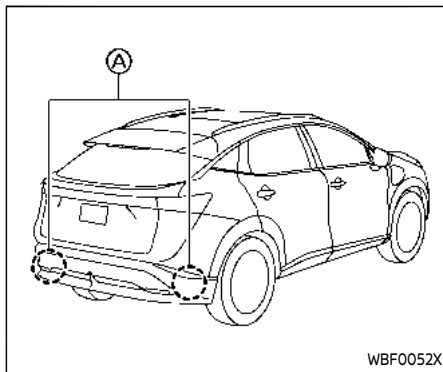

SYSTEM MAINTENANCE

The two radar sensors (A) for the BSW system are located near the rear bumper. Always keep the area near the radar sensors clean.

The radar sensors may be blocked by temporary ambient conditions such as splashing water, mist or fog.

The blocked condition may also be caused by objects such as ice, frost or dirt obstructing the radar sensors.

Check for and remove objects obstructing the area around the radar sensors.

Do not attach stickers (including transparent material), install accessories or

apply additional paint near the radar sensors.

Do not strike or damage the area around the radar sensors.

See a NISSAN certified ARIYA dealer or other authorized repair shop if the area around the radar sensors is damaged due to a collision.

Precautions on repairing the bumper

When repairing the bumper, take caution because the radar sensors are installed on the bumper.

The radar sensor detects objects by emitting a radar signal and then measuring its reflection.



WARNING

If an improper repair is performed on the bumper (for example, application of putty made from different materials, repaint, etc.) the radar signal could be weakened or prevented from functioning properly. This may cause the radar sensor not to detect objects correctly. Improper repair may result in serious personal injury. If it is necessary to repair the bumper, it is recommended you visit a

NISSAN certified ARIYA dealer for this service.

Radio frequency statement

For USA

FCC ID: WU877V13CRN

CAUTION TO USERS

Changes or modifications not expressly approved by the party responsible for compliance could void the user's authority to operate the equipment.

This device complies with Part 15 of the FCC Rules and with RSS of the Industry Canada. Operation is subject to the following two conditions:

(1) This device may not cause harmful interference, and

(2) this device must accept any interference received, including interference that may cause undesired operation

For Canada

Model: RN5TR

IC: 8436B-77V13CRN

This device contains license-exempt transmitter(s)/receiver(s) that comply with Innovation, Science and Economic Development Canada's license-exempt RSS(s). Operation is subject to the following two conditions: (1) This device

may not cause interference. (2) This device must accept any interference, including interference that may cause undesired operation of the device.

INTELLIGENT BLIND SPOT INTERVENTION (I-BSI)



WARNING

Failure to follow the warnings and instructions for proper use of the I-BSI system could result in serious injury or death.

- The I-BSI system is not a replacement for proper driving procedures and is not designed to prevent contact with vehicles or objects. When changing lanes, always use the side and rear mirrors and turn and look in the direction your vehicle will move to ensure it is safe to change lanes. Never rely solely on the I-BSI system.
- There is a limitation to the detection capability of the radar. Not every moving object or vehicle will be detected. Using the I-BSI system under some road, ground, lane marker, traffic or weather conditions could lead to improper system operation. Always rely on your own operation to avoid accidents.

The I-BSI system helps alert the driver of other vehicles in adjacent lanes when changing lanes, and helps assist the

driver to return the vehicle to the center of the traveling lane.

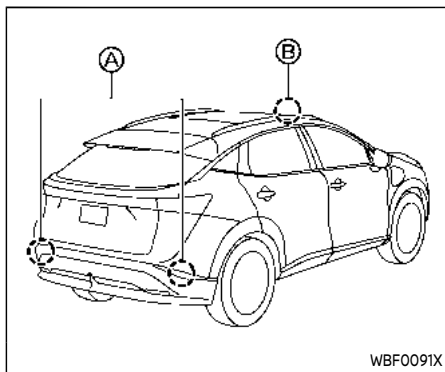

The I-BSI system uses radar sensors **A** installed near the rear bumper to detect other vehicles in an adjacent lane. In addition to the radar sensors, the I-BSI system uses a camera **B** installed behind the windshield to monitor the lane markers of your traveling lane.

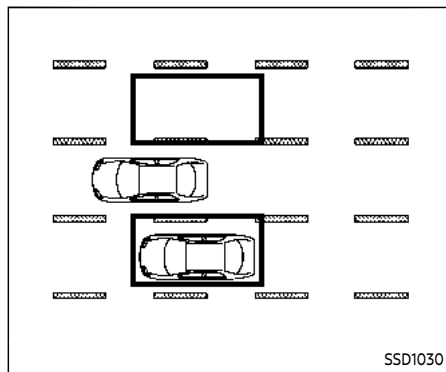

Detection zone

The radar sensors can detect vehicles on either side of your vehicle within the detection zone shown as illustrated.

This detection zone starts from the outside mirror of your vehicle and extends approximately 10 ft (3.0 m) behind the rear bumper, and approximately 10 ft (3.0 m) sideways.

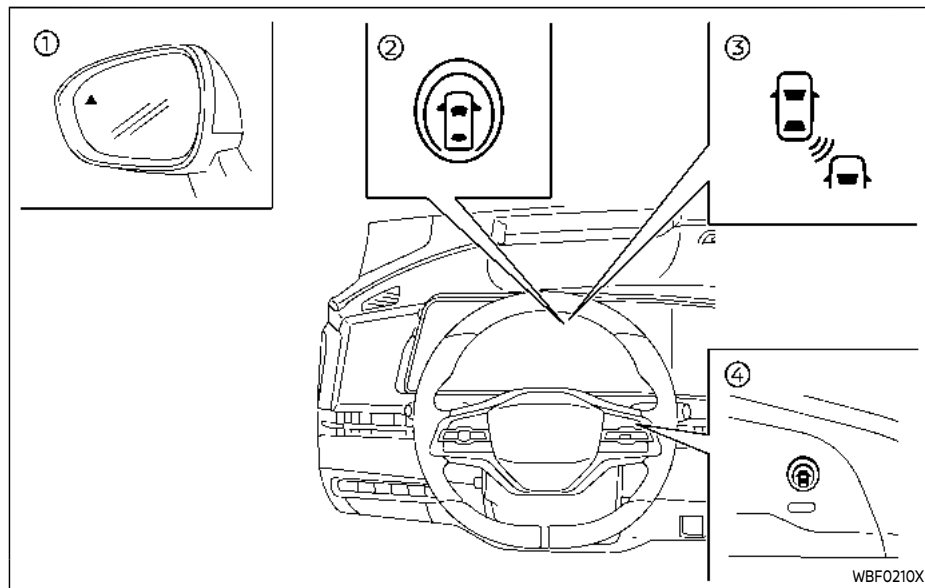

Example

- ① Side indicator light
- ② I-BSI ON indicator (on the vehicle information display)
- ③ I-BSI indicator (on the vehicle information display)
- ④ ProPILOT Assist switch (The design varies depending on the models.)

I-BSI SYSTEM OPERATION

The I-BSI system operates above approximately 37 MPH (60 km/h).

If the radar sensors detect a vehicle in the detection zone, the side indicator light illuminates.

If the turn signal is then activated, the system chimes (twice) and the side indicator light and I-BSI indicator flash. The side indicator light and I-BSI indicator continue to flash until the detected vehicle leaves the detection zone.

If the I-BSI system is ON and your vehicle approaches a lane marker while another vehicle is in the detection zone, the system chimes (three times) and the side indicator light and I-BSI indicator flash. The I-BSI system activates to help return the vehicle back to the center of the driving lane. The I-BSI system operates regardless of turn signal usage.

To turn on the I-BSI system, push the ProPILOT Assist switch on the steering wheel after starting the EV system. The I-BSI ON indicator on the vehicle information display will illuminate. Push the ProPILOT Assist switch again to turn off the I-BSI system.

NOTE:

- **I-BSI warning and system application will only be activated if the side indicator light is already illuminated when your vehicle approaches a lane marker. If another vehicle comes into the detection zone after your vehicle has crossed a lane marker, no I-BSI warning or system application will be activated. (For**

additional information, see "I-BSI driving situations" (P.5-69.)

- The I-BSI system is typically activated earlier than the Intelligent Lane Intervention (I-LI) system when your vehicle is approaching a lane marker.

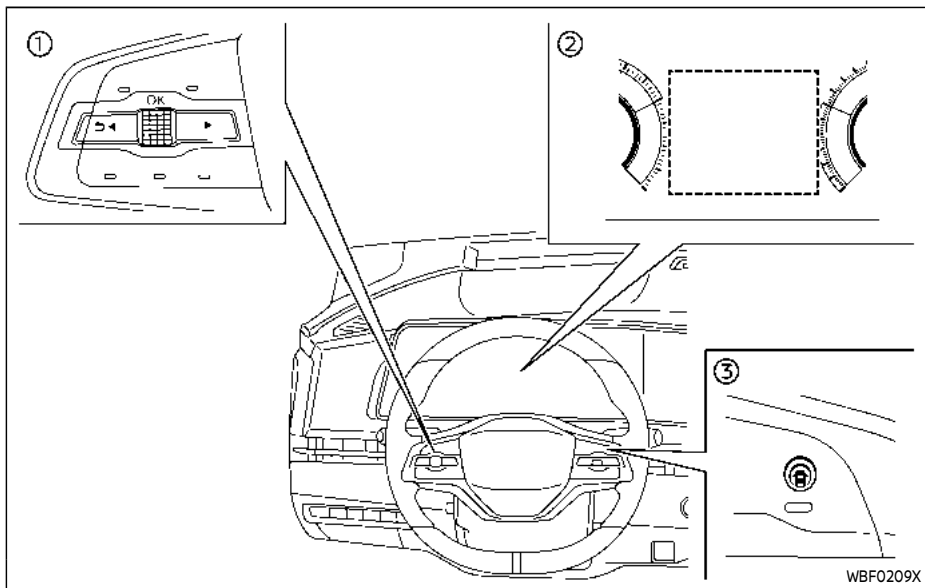

Example

- ① Steering-wheel-mounted control (left side)
- ② Vehicle information display
- ③ ProPILOT Assist switch (The design varies depending on the models.)

HOW TO ENABLE/DISABLE THE I-BSI SYSTEM

1. Push the ◀ ▶ button until "Settings" appears in the vehicle information display and then push the scroll dial. Use the scroll dial to select "Driver Assistance." Then push the scroll dial.

2. Select "Blind Spot Assist" and push the scroll dial.
3. Select "Intervention" and push the scroll dial.
4. Push the ProPILOT Assist switch to turn the system on or off.

NOTE:

Turning on the ProPILOT Assist system will turn on the I-BSI and I-LI systems at the same time. For additional information, see "Intelligent Lane Intervention (I-LI)" (P.5-49).

I-BSI SYSTEM LIMITATIONS



WARNING

Listed below are the system limitations for the I-BSI system. Failure to operate the vehicle in accordance with these system limitations could result in serious injury or death.

- The I-BSI system cannot detect all vehicles under all conditions.
- The radar sensors may not be able to detect and activate I-BSI when certain objects are present such as:
 - Pedestrians, bicycles, animals.

- Vehicles such as motorcycles, low height vehicles, or high ground clearance vehicles.

- Vehicles remaining in the detection zone when you accelerate from a stop.

- Oncoming vehicles.

- A vehicle merging into an adjacent lane at a speed approximately the same as your vehicle.

- A vehicle approaching rapidly from behind.

- A vehicle which your vehicle overtakes rapidly.

- A vehicle that passes through the detection zone quickly.

- The radar sensor's detection zone is designed based on a standard lane width. When driving in a wider lane, the radar sensors may not detect vehicles in an adjacent lane. When driving in a narrow lane, the radar sensors may detect vehicles driving two lanes away.
- The radar sensors are designed to ignore most stationary objects, however objects such as guard-

rails, walls, foliage and parked vehicles may occasionally be detected. This is a normal operation condition.

- The following conditions may reduce the ability of the radar to detect other vehicles:
 - Severe weather
 - Road spray
 - Ice/frost/dirt build-up on the vehicle
- Do not attach stickers (including transparent material), install accessories or apply additional paint near the radar sensors. These conditions may reduce the ability of the radar to detect other vehicles.
- The camera may not detect lane markers in the following situations and the I-BSI system may not operate properly.
 - On roads where there are multiple parallel lane markers; lane markers that are faded or not painted clearly; yellow painted lane markers; non-standard lane markers; lane markers covered with water, dirt, snow, etc.

- On roads where discontinued lane markers are still detectable.
- On roads where there are sharp curves.
- On roads where there are sharply contrasting objects, such as shadows, snow, water, wheel ruts, seams or lines remaining after road repairs.
- On roads where the traveling lane merges or separates.
- When the vehicle's traveling direction does not align with the lane markers.
- When traveling close to the vehicle in front of you, which obstructs the lane camera unit detection range.
- When rain, snow or dirt adheres to the windshield in front of a lane camera unit.
- When the headlights are not bright due to dirt on the lens or if aiming is not adjusted properly.
- When strong light enters a lane camera unit. (For exam-

ple: light directly shines on the front of the vehicle at sunrise or sunset.)

- When a sudden change in brightness occurs. (For example: when the vehicle enters or exits a tunnel or under a bridge.)
- Do not use the I-BSI system under the following conditions because the system may not function properly.
 - During bad weather. (For example: rain, fog, snow, etc.)
 - When driving on slippery roads, such as on ice or snow, etc.
 - When driving on winding or uneven roads.
 - When there is a lane closure due to road repairs.
 - When driving in a makeshift or temporary lane.
 - When driving on roads where the lane width is too narrow.
 - When driving with a tire that is not within normal tire conditions (for example, tire wear, low tire pressure, installation

of tire chains or non-standard wheels).

- When the vehicle is equipped with non-original steering parts or suspension parts.
- When towing a trailer or other vehicle (AWD models).
- Excessive noise (for example, audio system volume, open vehicle window) will interfere with the chime sound, and it may not be heard.

I-BSI DRIVING SITUATIONS

Indicator on



Indicator off



Indicator flashing

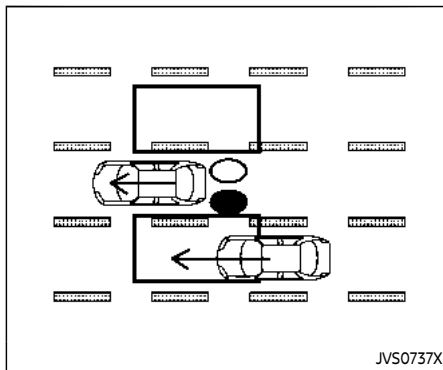

Illustration 1 – Approaching from behind

Another vehicle approaching from behind

Illustration 1: The side indicator light illuminates if a vehicle enters the detection zone from behind in an adjacent lane.

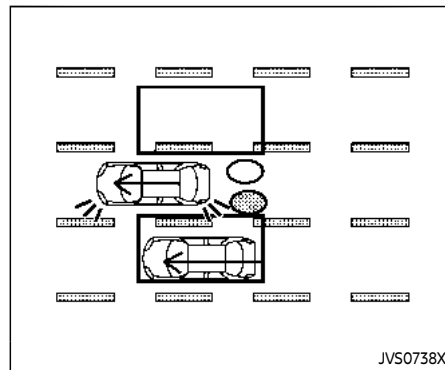

Illustration 2 – Approaching from behind

Illustration 2: If the driver activates the turn signal then the system chimes a sound (twice) and the side indicator light and I-BSI indicator flash.

NOTE:

If the driver activates the turn signal before a vehicle enters the detection zone, the side indicator light and I-BSI indicator will flash but no chime will sound when the other vehicle is detected.

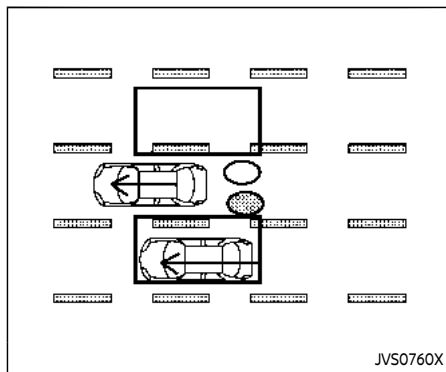

Illustration 3 - Approaching from behind

Illustration 3: If the I-BSI system is on and your vehicle approaches a lane marker while another vehicle is in the detection zone, the system chimes (three times) and the side indicator light and I-BSI indicator flash. The I-BSI system activates to help return the vehicle back to the center of the driving lane.

NOTE:

- The radar sensors may not detect vehicles which are approaching rapidly from behind.

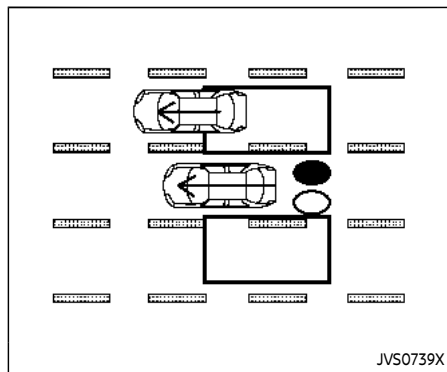

Illustration 4 - Overtaking another vehicle

Overtaking another vehicle

Illustration 4: The side indicator light illuminates if you overtake a vehicle and that vehicle stays in the detection zone for approximately 3 seconds.

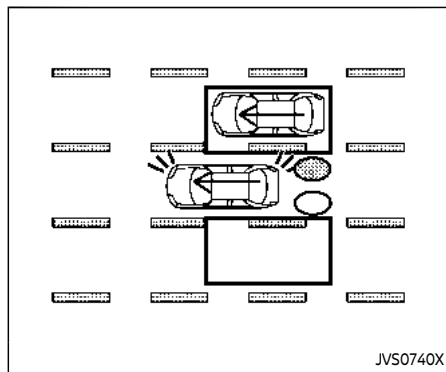

Illustration 5 - Overtaking another vehicle

Illustration 5: If the driver activates the turn signal while another vehicle is in the detection zone, then the system chimes (twice) and the side indicator light and I-BSI indicator flash.

NOTE:

If the driver activates the turn signal before a vehicle enters the detection zone, the side indicator light and I-BSI indicator will flash but no chime will sound when the other vehicle is detected.

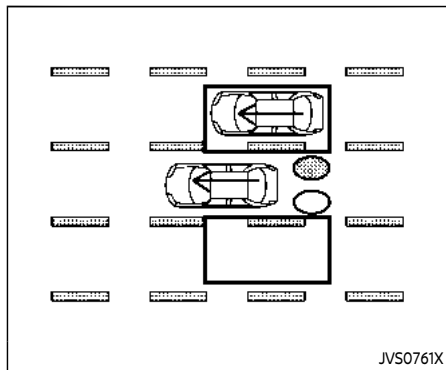

Illustration 6 - Overtaking another vehicle

Illustration 6: If the I-BSI system is on and your vehicle approaches a lane marker while another vehicle is in the detection zone, the system chimes (three times) and the side indicator light and I-BSI indicator flash. The Intelligent Blind Spot Intervention (I-BSI) system activates to help return the vehicle back to the center of the driving lane.

NOTE:

- When overtaking several vehicles in a row, the vehicles after the first vehicle may not be detected if they are traveling close together.

- The radar sensors may not detect slower moving vehicles if they are passed quickly.

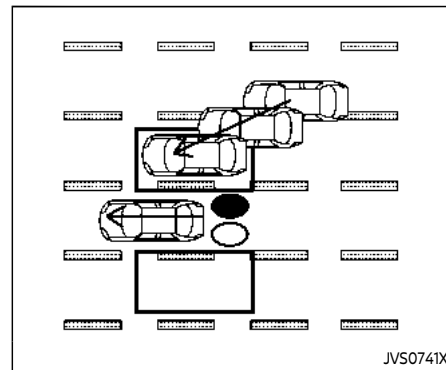

Illustration 7 - Entering from the side

Entering from the side

Illustration 7: The side indicator light illuminates if a vehicle enters the detection zone from either side.

NOTE:

The radar sensors may not detect a vehicle which is traveling at about the same speed as your vehicle when it enters the detection zone.

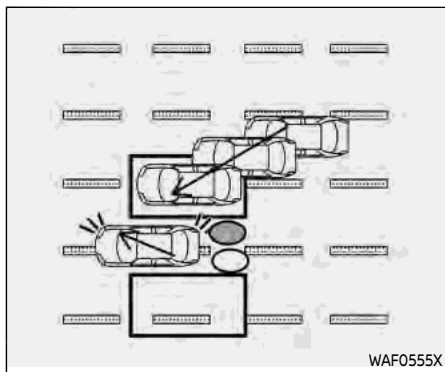

Illustration 8 - Entering from the side

Illustration 8: If the driver activates the turn signal while another vehicle is in the detection zone, then the side indicator light and I-BSI indicator flash and a chime will sound twice.

NOTE:

- **If the driver activates the turn signal before a vehicle enters the detection zone, the side indicator light and I-BSI indicator will flash but no chime will sound when another vehicle is detected.**

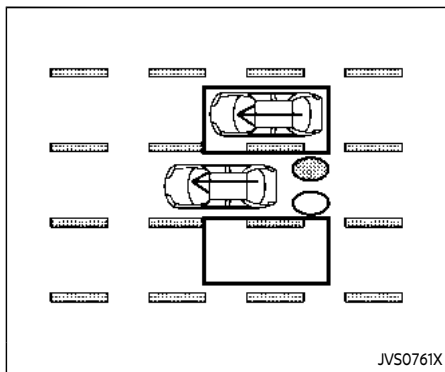

Illustration 9 - Entering from the side

Illustration 9: If the I-BSI system is on and your vehicle approaches the lane marker while another vehicle is in the detection zone, the system chimes (three times) and the side indicator light and I-BSI indicator flash. The I-BSI system activates to help return the vehicle back to the center of the driving lane.

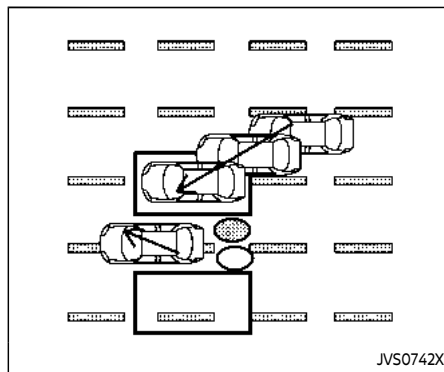

Illustration 10 - Entering from the side

Illustration 10: The I-BSI system will not operate if your vehicle is on a lane marker when another vehicle enters the detection zone. In this case only the BSW system operates.

NOTE:

- **The radar sensors may not detect a vehicle which is traveling at about the same speed as your vehicle when it enters the detection zone.**
- **Intelligent Blind Spot Intervention (I-BSI) will not operate or will stop operating and only a warning chime will sound under the following conditions.**

- When the brake pedal is depressed.
- When the vehicle is accelerated during I-BSI system operation
- When steering quickly
- When the ICC, I-FCW or AEB warnings sound.
- When the hazard warning flashers are operated.
- When driving on a curve at a high speed.
- When the BSW system is turned off.

SYSTEM TEMPORARILY UNAVAILABLE

When any of the following messages appear on the vehicle information display, a chime will sound and the I-BSI system will be turned off automatically.

- “Unavailable Slippery Road”:
When the VDC system (except traction control system function) or ABS operates.
- “Currently unavailable”:
 - When the VDC system is turned off.
 - When the SNOW mode is selected (AWD models).
- “Unavailable Camera Temperature High”:
If the vehicle is parked in direct sun-

light under high temperature conditions (over approximately 104°F (40°C)).

- “Unavailable Side Radar Obstruction”:
When side radar blockage is detected.
Turn off the I-BSI system and turn it on again when the above conditions no longer exist.

See “Driver assistance troubleshooting guide” (P.5-36).

SYSTEM MALFUNCTION

When the I-BSI system malfunctions, it will be turned off automatically, the I-BSI indicator illuminates and a chime will sound, and the “Malfunction See Owner’s Manual” warning message will appear in the vehicle information display.

Action to take:

Stop the vehicle in a safe location and push the park button to engage the P (Park) position. Turn the EV system off and restart the EV system. If the warning message continues to appear, it is recommended you visit a NISSAN certified ARIYA dealer for this service.

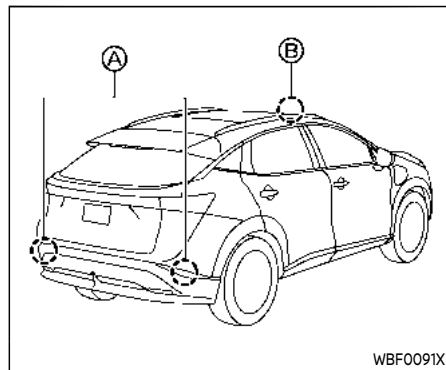

SYSTEM MAINTENANCE

The two radar sensors **A** for the I-BSI system are located near the rear bumper. Always keep the area near the radar sensors clean.

The radar sensors may be blocked by temporary ambient conditions such as splashing water, mist or fog.

The blocked condition may also be caused by objects such as ice, frost or dirt obstructing the radar sensors.

Check for and remove objects obstructing the area around the radar sensors.

Do not attach stickers (including transparent material), install accessories or

apply additional paint near the radar sensors.

Do not strike or damage the area around the radar sensors.

It is recommended you visit a NISSAN certified ARIYA dealer if the area around the radar sensors is damaged due to a collision.

The lane camera unit ® for I-BSI system is located above the inside mirror. To keep the proper operation of I-BSI and prevent a system malfunction, be sure to observe the following:

- Always keep the windshield clean.
- Do not attach a sticker (including transparent material) or install an accessory near the camera unit.
- Do not place reflective materials, such as white paper or a mirror, on the instrument panel. The reflection of sunlight may adversely affect the camera unit's capability of detecting the lane markers.
- Do not strike or damage the areas around the camera unit. Do not touch the camera lens or remove the screw located on the camera unit. It is recommended you contact a NISSAN certified ARIYA dealer if the camera unit is damaged due to an accident.

Precautions on repairing the bumper

When repairing the bumper, take caution because the radar sensors are installed on the bumper.

The radar sensor detects objects by emitting a radar signal and then measuring its reflection.



WARNING

If an improper repair is performed on the bumper (for example, application of putty made from different materials, repaint, etc.) the radar signal could be weakened or prevented from functioning properly. This may cause the radar sensor not to detect objects correctly. Improper repair may result in serious personal injury. If it is necessary to repair the bumper, it is recommended you visit a NISSAN certified ARIYA dealer for this service.

Radio frequency statement

For USA

FCC ID: LTQRN5TR

CAUTION TO USERS

Changes or modifications not expressly approved by the party responsible for compliance could void the user's authority to operate the equipment.

This device complies with Part 15 of the FCC Rules and with RSS of the Industry Canada. Operation is subject to the following two conditions:

(1) This device may not cause harmful interference, and

(2) this device must accept any interference received, including interference that may cause undesired operation

For Canada

Model: RN5TR

IC: 3659A-RN5TR

This device complies with Industry Canada licence-exempt RSS standard(s). Operation is subject to the following two conditions: (1) this device may not cause interference, and (2) this device must accept any interference, including interference that may cause undesired operation of the device.

REAR CROSS TRAFFIC ALERT (RCTA)

WARNING

Failure to follow the warnings and instructions for proper use of the RCTA system could result in serious injury or death.

- The RCTA system is not a replacement for proper driving procedures and is not designed to prevent contact with vehicles or objects. When backing out of a parking space, always use the side and rear mirrors and turn and look in the direction your vehicle will move. Never rely solely on the RCTA system.

The RCTA system will assist you when backing out from a parking space. When the vehicle is in reverse, the system is designed to detect other vehicles approaching from the right or left of the vehicle. If the system detects cross traffic, it will alert you.

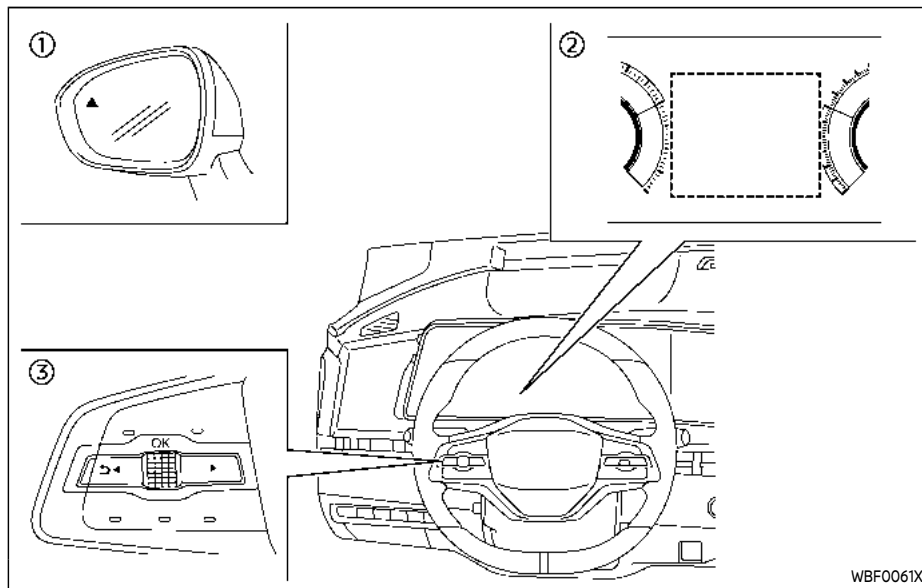

- ① Side indicator light
- ② Vehicle information display
- ③ Steering-wheel-mounted controls (left side)

RCTA SYSTEM OPERATION

The RCTA system can help alert the driver of an approaching vehicle when the driver is backing out of a parking space.

When the shift position is in R (Reverse) and the vehicle speed is less than approximately 5 MPH (8 km/h), the RCTA

system is operational.

If the radar detects an approaching vehicle from either side, the system chimes (once) and the side indicator light flashes on the side the vehicle is approaching from.

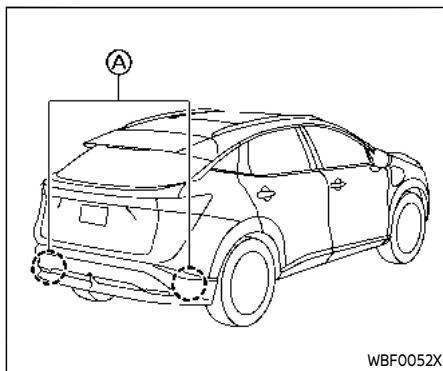
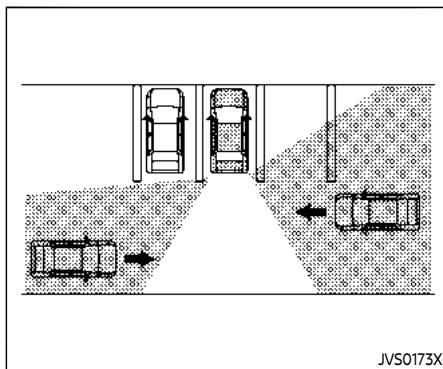

The RCTA system uses radar sensors **A** installed on both sides near the rear bumper to detect an approaching vehicle.

The radar sensors can detect an approaching vehicle from up to approximately 66 ft (20 m) away.

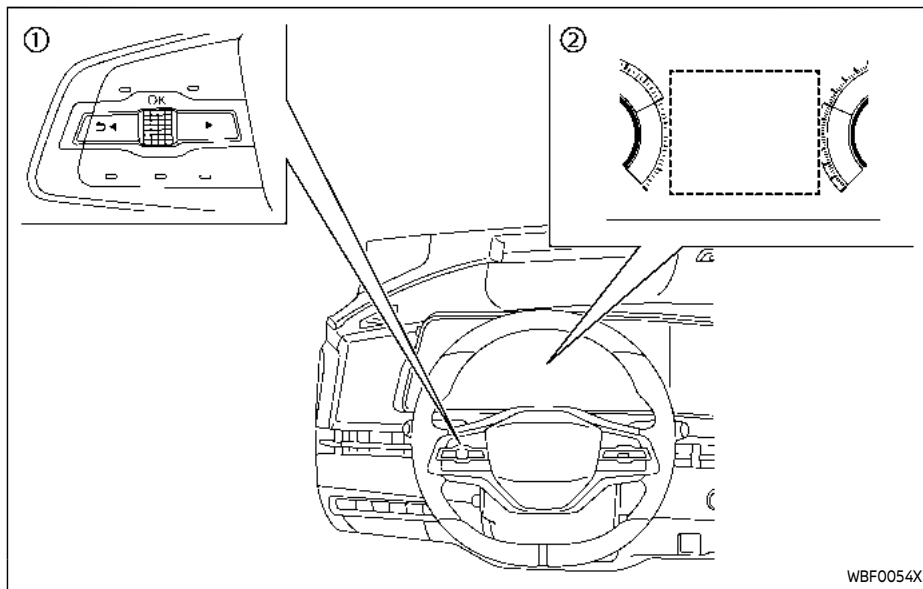

- ① Steering-wheel-mounted controls (left side)
- ② Vehicle information display

HOW TO ENABLE/DISABLE THE RCTA SYSTEM

Perform the following steps to enable or disable the RCTA system.

1. Push the ◀ ▶ button until "Settings" appears in the vehicle information display and then push the scroll

dial. Use the scroll dial to select "Driver Assistance". Then push the scroll dial.

2. Select "Parking Assist" and push the scroll dial.
3. Select "Rear Cross Traffic Alert" and push the scroll dial to turn the system on or off.

NOTE:

The system setting will be retained even if the EV system is restarted.

WBF0054X

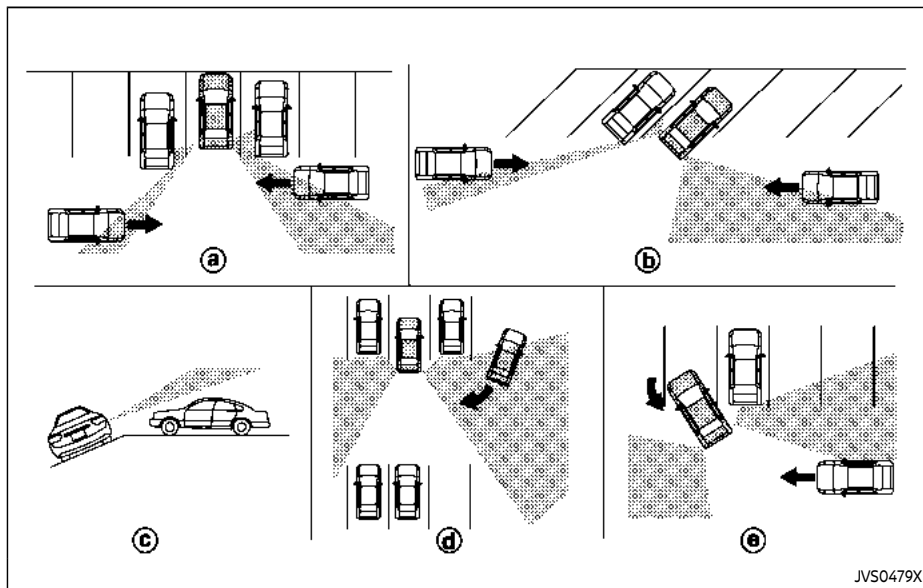

RCTA SYSTEM LIMITATIONS

WARNING

Listed below are the system limitations for the RCTA system. Failure to operate the vehicle in accordance with these system limitations could result in serious injury or death.

- Always check surroundings and turn to check what is behind you before backing up. The radar sensors detect approaching (moving) vehicles. The radar sensors cannot detect every object such as:
 - Pedestrians, bicycles, motorcycles, animals or child-operated toy vehicles
 - A vehicle that is passing at speeds greater than approximately 19 MPH (30 km/h)
 - A vehicle that is passing at speeds lower than approximately 5 MPH (8 km/h)
- The radar sensors may not detect approaching vehicles in certain situations:

- Illustration ③: When a vehicle parked next to you obstructs the beam of the radar sensor.
- Illustration ④: When the vehicle is parked in an angled parking space.
- Illustration ⑤: When the vehicle is parked on inclined ground.
- Illustration ⑥: When an approaching vehicle turns into your vehicle's parking lot aisle.
- Illustration ⑦: When the angle formed by your vehicle and approaching vehicle is small
- The following conditions may reduce the ability of the radar to detect other vehicles:
 - Severe weather
 - Road spray
 - Ice/frost/dirt build-up on the vehicle
- Do not attach stickers (including transparent material), install accessories or apply additional paint near the radar sensors. These conditions may reduce the ability of the radar to detect other vehicles

- When towing a trailer or other vehicle, turn the RCTA system off to prevent the occurrence of an unexpected accident resulting from sudden system operation.
- Excessive noise (e.g. audio system volume, open vehicle window) will interfere with the chime sound, and it may not be heard.

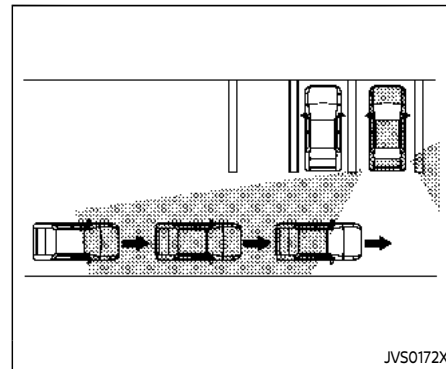

Illustration 1

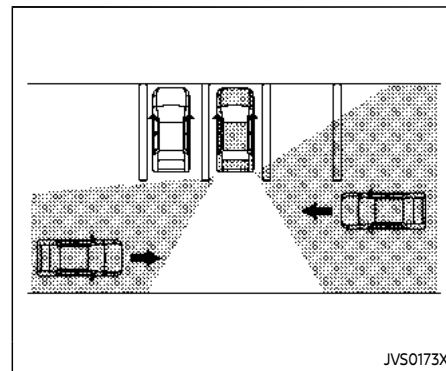

Illustration 2

NOTE:

In the case of several vehicles approaching in a row (Illustration 1) or in the opposite direction (Illustration 2), a chime may not be sounded by the RCTA system after the first vehicle passes the sensors.

SYSTEM TEMPORARILY UNAVAILABLE

When radar blockage is detected, the system will be deactivated automatically. The "Unavailable Side Radar Obstruction" warning message will appear in the vehicle information display.

The systems are not available until the conditions no longer exist.

The radar sensors may be blocked by temporary ambient conditions such as splashing water, mist or fog.

The blocked condition may also be caused by objects such as ice, frost or dirt obstructing the radar sensors.

NOTE:

If the BSW system stops working, the RCTA and Intelligent Blind Spot Intervention (I-BSI) systems will also stop working.

Action to take:

When the above conditions no longer exist, the system will resume automati-

cally.

See "Driver assistance troubleshooting guide" (P.5-36).

SYSTEM MALFUNCTION

When the RCTA system malfunctions, it will turn off automatically. The "Malfunction See Owner's Manual" warning message will appear in the vehicle information display.

NOTE:

If the BSW system stops working, the RCTA and I-BSI system will also stop working.

Action to take:

Stop the vehicle in a safe location, turn the EV system off and restart the EV system. If the message continues to appear, have the system checked. It is recommended that you visit a NISSAN certified ARIYA dealer for this service.

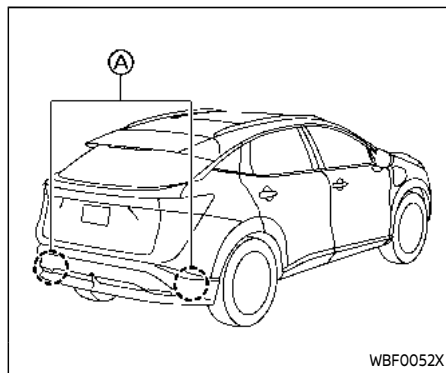
**SYSTEM MAINTENANCE**

The two radar sensors (A) for the RCTA system are located near the rear bumper. Always keep the area near the radar sensors clean.

The radar sensors may be blocked by temporary ambient conditions such as splashing water, mist or fog.

The blocked condition may also be caused by objects such as ice, frost or dirt obstructing the radar sensors.

Check for and remove objects obstructing the area around the radar sensors.

Do not attach stickers (including transparent material), install accessories or

apply additional paint near the radar sensors.

Do not strike or damage the area around the radar sensors. It is recommended that you visit a NISSAN certified ARIYA dealer if the area around the radar sensors is damaged due to a collision.

Precautions on repairing the bumper

When repairing the bumper, take caution because the radar sensors are installed on the bumper.

The radar sensor detects objects by emitting a radar signal and then measuring its reflection.



WARNING

If an improper repair is performed on the bumper (for example, application of putty made from different materials, repaint, etc.) the radar signal could be weakened or prevented from functioning properly. This may cause the radar sensor not to detect objects correctly. Improper repair may result in serious personal injury. If it is necessary to repair the bumper, it is recommended you visit a NISSAN certified ARIYA dealer for this

service.

Radio frequency statement

For USA

FCC ID: WU877V13CRN

CAUTION TO USERS

Changes or modifications not expressly approved by the party responsible for compliance could void the user's authority to operate the equipment.

This device complies with Part 15 of the FCC Rules and with RSS of the Industry Canada. Operation is subject to the following two conditions:

- (1) This device may not cause harmful interference, and
- (2) this device must accept any interference received, including interference that may cause undesired operation

For Canada

Model: RN5TR

IC: 8436B-77V13CRN

This device contains license-exempt transmitter(s)/receiver(s) that comply with Innovation, Science and Economic Development Canada's license-exempt RSS(s). Operation is subject to the following two conditions: (1) This device may not cause interference. (2) This

device must accept any interference, including interference that may cause undesired operation of the device.

PROPILOT ASSIST SYSTEMS

OVERVIEW

ProPILOT Assist is a hands on driver assistance system intended for limited access expressways and not designed to be used on city/rural streets. The system is intended to help keep the vehicle in the center of the lane and maintain a preset distance to the vehicle ahead traveling in the same lane. There are three available levels of ProPILOT Assist which include the following additional features:

ProPILOT Assist:

- Intelligent Cruise Control (P.5-98)
- Steering Assist (P.5-106)

ProPILOT Assist with Navi-link (includes features of ProPILOT Assist):

- Speed Adjust by Route (P.5-105)
- Speed Limit Assist (P.5-103)
- Extended stop (See "Intelligent Cruise Control (ICC)" (P.5-98).)

ProPILOT Assist 2.0 (if so equipped) (includes features of ProPILOT Assist with Navi-link):

- Steering Assist with HD map data (P.5-110)
- Lane Change Assist (P.5-113)
- Route Assist (P.5-118)
- Passing Assist (P.5-115)

NOTE:

A subscription is required for ProPILOT Assist 2.0 features.

To determine if your vehicle is equipped:

ProPILOT Assist and ProPILOT Assist with Navi-link will have a steering wheel similar to this image and only one roof mounted antenna:

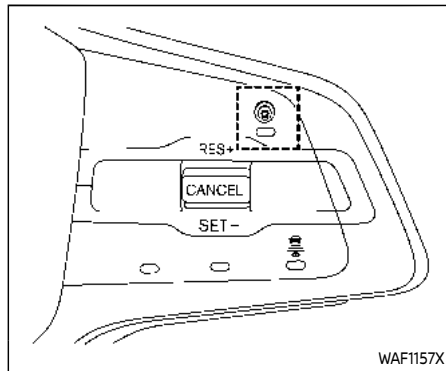

NOTE:

ProPILOT Assist with Navi-link is only on vehicles equipped with an in-vehicle navigation system.

ProPILOT Assist 2.0 will have a steering wheel similar to this image and two roof mounted antennas (right side is GNSS antenna):

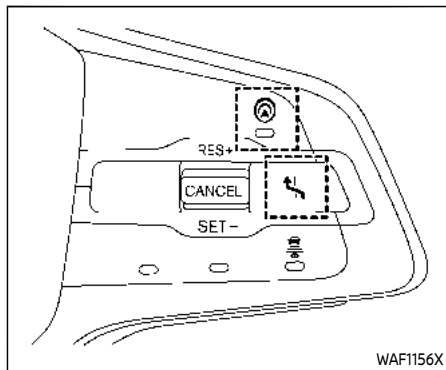

NOTE:

It is important to understand which features your vehicle is equipped as some portions of this section may not be applicable.



WARNING

Applicable to ProPILOT Assist suite of systems, including ProPILOT Assist 2.0, ProPILOT Assist, ProPILOT Assist with Navi-link, Intelligent Cruise Control (ICC), Steering Assist, Lane Change Assist, Passing Assist, Route Assist, Driver Monitoring System and conventional (fixed speed) cruise

control, referenced below as “ProPILOT Assist systems” (All systems if so equipped).

- Failure to follow the following warnings and instructions for proper use of the ProPILOT Assist systems, as applicable, could result in an accident causing serious injury or death.
- Always drive carefully and attentively when using the ProPILOT Assist systems. Read and understand the Owner’s Manual thoroughly before using the ProPILOT Assist systems. To avoid serious injury or death, do not rely on the systems to prevent accidents or to control the vehicle’s speed in emergency situations.
- Do not use the ProPILOT Assist systems except in appropriate road and traffic conditions.
- The ProPILOT Assist systems are for limited access freeway use only and are not intended for city driving.
- The ProPILOT Assist systems are not self-driving systems. Within the limits of their capabilities, as described in this manual, they help the driver with certain driv-

ing activities.

- The ProPILOT Assist systems are not replacements for proper driving procedures and will not correct careless, inattentive or absent-minded driving. Regardless of which system or function is being used, it is the driver’s responsibility to stay alert, drive safely, and be in control of the vehicle at all times. Failure to apply the brakes or steer the vehicle when necessary may result in a serious accident.
- The ProPILOT Assist systems are only aids to assist the driver and are not collision warning or avoidance devices.
- There are limitations to the ProPILOT Assist systems’ capabilities. Never rely solely on these systems. The ProPILOT Assist systems do not function in all driving, traffic, weather and road conditions.
- Never unfasten your safety seat belt when using the ProPILOT Assist. Doing so automatically cancels the ProPILOT Assist systems.

- When using the ProPILOT Assist systems, always observe posted speed limits and do not set the speed over them.
- When the accelerator pedal is depressed, the ProPILOT Assist systems will not provide automatic braking and/or the approach warning. The driver must manually control the vehicle speed to maintain a safe distance to the vehicle ahead. Failure to do so could result in severe personal injury or death.
- Do not rely on the ProPILOT Assist systems to prevent accidents. The driver must maintain a safe distance to the vehicle ahead by braking or accelerating, depending on the surrounding circumstances.
- When using Steering Assist, it is the driver's responsibility to stay alert, drive safely, keep the vehicle in the traveling lane and be in control of the vehicle at all times. Never take your hands off the steering wheel while driving unless the driving conditions allow and the ProPILOT Assist system is in Hands Off mode. Keep your hands on the steering wheel and

drive the vehicle safely.

- Steering Assist is intended for use on limited access freeways with gentle (moderate) curves. To avoid risk of an accident, do not use this system on local or non-highway/freeway roads.
- Steering Assist only steers the vehicle to maintain its position in the center of a lane. The vehicle will not steer to avoid objects in the road in front of the vehicle, to avoid a vehicle moving into your lane or to avoid a vehicle approaching from the side.
- Lane Change Assist, Passing Assist, and Route Assist only assist the driver to make a lane change. These systems do not steer the vehicle to avoid a collision. Be sure to keep your hands on the steering wheel and move safely to a different lane.
- Route Assist may not help the vehicle proceeding to the exit or junction, for example, when the other vehicles are stopped on the exit or junction. Stay alert to the surrounding vehicles and operate the steering wheel to proceed to the exit or junction.

- When using conventional (fixed speed) cruise control mode, a warning chime does not sound to warn you if you are too close to the vehicle ahead, as neither the presence of the vehicle ahead nor the vehicle-to-vehicle distance is detected. Pay special attention to the distance between your vehicle and the vehicle ahead of you, or a collision could occur.
- Always confirm the setting in the ICC system display.
- Do not use the conventional (fixed speed) cruise control mode when driving under the following conditions (doing so could cause a loss of vehicle control and result in an accident):
 - When it is not possible to keep the vehicle at a set speed
 - In heavy traffic or in traffic that varies in speed
 - On winding or hilly roads
 - On slippery roads (rain, snow, ice, etc.)
 - In very windy areas

PROPILOT ASSIST SYSTEMS OVERVIEW

Each ProPILOT Assist feature is designed to help the driver in different ways as they drive.

Here is a summary of these features. See the specified page for detailed information.

Feature Name	Feature Description
Conventional (fixed speed) Cruise Control	Allows the driver to drive the vehicle at a fixed speed without keeping their foot on the accelerator pedal.
Intelligent Cruise Control (ICC)	<ul style="list-style-type: none">● Helps the driver maintain a selected distance from the vehicle ahead and can reduce the speed to match a slower vehicle ahead.● Decelerates the vehicle to a standstill when a vehicle ahead slows to a stop.
Extended Stop	Enables the vehicle to start moving again automatically if vehicle is stopped for less than approximately 30 seconds on the highway
Speed Limit Assist	A feature of the Intelligent Cruise Control that detects a change of the speed limit, indicates the detected speed limit sign and can apply to the vehicle set speed automatically or manually.
Speed Adjust by Route	A feature of Intelligent Cruise Control that adjusts the vehicle speed depending on curves, junctions and exits, using road information provided by the navigation system.
Steering Assist	<ul style="list-style-type: none">● Assists the driver to help keep the vehicle within the center of the traveling lane.● Traffic and other conditions and laws permit, and it is safe to do so, driver's hands can be taken off the steering wheel. Always pay attention to the road and the operation of the vehicle.
Lane Change Assist	Help the driver make a lane change when the turn signal is activated.
Passing Assist	Help the driver make a lane change when a slower vehicle is detected ahead (A feature of ProPILOT Assist 2.0).
Route Assist	Help the driver make a lane change when approaching the point where a lane change is necessary, according to the route set in the navigation system.

PROPILOT ASSIST 2.0 MODE INDICATORS

ProPILOT Assist has a variety of modes depending on various conditions and are represented by color. The system will automatically transition to the highest available mode when conditions are met. The table below shows the available system modes and the required conditions.

Mode indicator	Active Systems
OFF	<ul style="list-style-type: none">● No systems active – driver initiation required
Gray	<ul style="list-style-type: none">● No systems active – driver activation required
White	<ul style="list-style-type: none">● Intelligent Cruise Control (ICC) active
Green	<ul style="list-style-type: none">● ICC and Steering Assist active● Driver is holding the steering control
Blue	<ul style="list-style-type: none">● ICC and Steering Assist active● Driver is paying attention to the traffic and other conditions and laws permit, and it is safe to do so, driver is able to take off their hands from the steering wheel.

How it works:

ProPILOT Assist Systems (if so equipped) uses some or all of the following components:

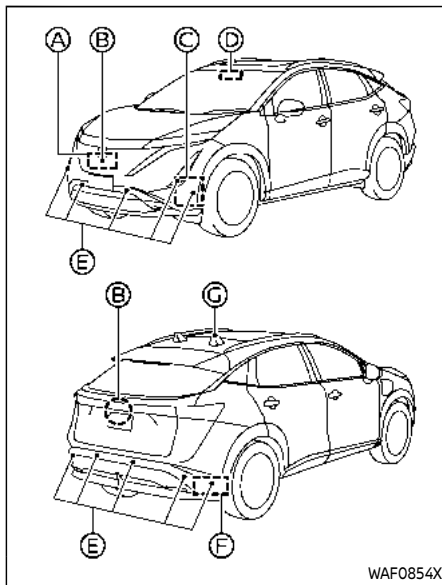

- (A) **Front radar sensor:**
Monitors the vehicle ahead in the same and adjacent lanes.
- (B) **Intelligent Around View® Monitor cameras (front and rear):**
Monitor motorcycles in the adjacent lanes (supplemental to the side radar sensors).

- (C) **Side radar sensors (front) (ProPILOT Assist 2.0 only):**
Monitor the other vehicles and empty spaces in the adjacent lanes.
- (D) **Tri-Camera (ProPILOT Assist 2.0)/Multi-sensing front camera (ProPILOT Assist with Navi-link):**
Monitors the other vehicles and empty spaces in adjacent lanes as well as lane markings.
- (E) **Sonar sensors:**
Monitor the vehicles on the sides and rear (ProPILOT Assist 2.0 only) of the vehicle.
- (F) **Side radar sensors (rear):**
Monitor the other vehicles in the adjacent lanes and approaching from the rear (i.e. blind spot).
- (G) **GNSS antenna (ProPILOT Assist 2.0 only)**
Used to gather GNSS signal to understand vehicle positioning.

NOTE:

It is important to ensure the radar sensors, cameras and sonar sensors are clear before each drive. Unclean or damaged cameras and sensors, as well as environmental conditions, can affect system performance. See "Driver assistance troubleshooting guide" (P.5-36) for more information.

Always keep the area near the radar sensors clean.

The radar sensors may be blocked by temporary ambient conditions such as splashing water, mist or fog.

The blocked condition may also be caused by objects such as ice, frost or dirt obstructing the radar sensors.

Check for and remove objects obstructing the area around the radar sensors.

Do not attach stickers (including transparent material), install accessories or apply additional paint near the radar sensors.

Do not strike or damage the area around the radar sensors.

See a NISSAN certified ARIYA dealer or other authorized repair shop if the area around the radar sensors is damaged due to a collision.

Precautions on repairing the bumper

When repairing the bumper, take caution because the radar sensors are installed on the bumper.

The radar sensor detects objects by emitting a radar signal and then measuring its reflection.



WARNING

If an improper repair is performed on the bumper (for example, application of putty made from different materials, repaint, etc.) the radar signal could be weakened or prevented from functioning properly. This may cause the radar sensor not to detect objects correctly. Improper repair may result in serious personal injury. If it is necessary to repair the bumper, it is recommended you visit a NISSAN certified ARIYA dealer for this service.

Limitations

Many factors can impact the performance of ProPILOT Assist systems, causing the systems not to perform as intended. ProPILOT Assist functions should not be used in certain situations. These include (but are not limited to):

- Poor visibility due to heavy rain, snow, ice, fog, etc.
- Bright light (due to oncoming traffic, direct sunlight, etc.)
- Obstruction to radars, sensors and cameras caused by mud, dirt, ice, snow, etc.
- Interference to sensors and radars (such as a bike rack, decals, etc.)
- Faded or inconsistent lane markings
- Construction zones
- Barren landscape
- Wide or narrow lanes
- Hard deceleration
- Tollbooths

ProPILOT Assist may not react to:

- Stationary vehicles
- Pedestrians, bicycles or animals
- Road debris
- Road pylon in a construction zone

See “Overview” (P.5-82) for additional system limitations.



WARNING

Listed below are the system limitations for the ProPILOT Assist functions and systems, including ProPILOT Assist with Navi-link, ProPILOT Assist 2.0, Intelligent Cruise Control (ICC), Steering Assist, Lane Change Assist, Route Assist). Failure to operate the vehicle in accordance with these system limitations could result in serious injury or death:

- These systems are primarily intended for use on freeways. It is not advisable to use these systems in city/urban traffic.
- These systems will not adapt automatically to all road conditions. They should be used in evenly flowing traffic. Do not use these systems on roads with sharp curves or in inclement weather or adverse road conditions.
- There are performance limits to all ProPILOT Assist functions. Never rely solely on these systems. These systems do not correct careless, inattentive, or absent-minded driving or overcome poor visibility in inclement

weather.

- When using these systems, the driver must be attentive to the driving task. When necessary, decelerate the vehicle speed by using the brake pedal, accelerate using the accelerator pedal, and steer the vehicle as appropriate in order to maintain a safe distance between vehicles and manage changing or dynamic traffic, vehicle and roadway conditions.
- When the ProPILOT Assist function automatically brings the vehicle to a stop, your vehicle can automatically accelerate if the vehicle is stopped for less than approximately 30 seconds on the freeway. Always be prepared to apply the brakes and stop your vehicle if necessary.
- Always check your surroundings before restarting the vehicle when it has been at a stop.
- These systems are not designed to detect anything other than motorized vehicles travelling in the same direction on the roadway. In particular, the systems do not detect the following objects:

- Pedestrians, animals or objects in the roadway
- Oncoming vehicles in the same lane
- Motorcycles travelling offset in the travel lane
- Road debris
- In the following situations, the ProPILOT Assist functions and system may not operate properly. To avoid accidents or unwanted system operation, never use these systems under the following conditions:
 - On roads with heavy, high-speed traffic or sharp curves
 - On slippery or adverse road surfaces, such as on wet, icy or snowy roads, or when roadway traffic is causing adverse travel conditions (i.e. road spray from passing vehicles)
 - On unpaved or uneven roadway surfaces, or on steep uphill or downhill roads
 - During inclement weather, such as rain, snow, fog, ice, sandstorms or dust storms

- When sensor detection capabilities are reduced, for example:
 - When snow/ice/dirt are covering the sensors or the camera area of the windshield is fogged up
 - When objects, such as stickers, bike racks or cargo obstruct the vehicle sensors
 - When strong light (for example, sunlight or high beams from oncoming vehicles) enters the cameras or there is a sudden change in brightness (for example, entering or exiting a tunnel or driving under a bridge)
- When traffic conditions make it difficult to keep a proper distance between vehicles because of frequent acceleration or deceleration, or when the cut-in detection function or approach warning activates frequently
- When a complicated-shaped vehicle, such as a car carrier trailer or flatbed truck/trailer is near the vehicle ahead

- When there is interference by other radar sources
- When driving with vehicle equipment that is not original to the vehicle (for example, equipped with non-original brake, tire or suspension parts) or not within normal conditions (for example, tire wear, abnormal tire pressure, installation of tire chains, reduced headlight brightness)
- When excessively heavy baggage is loaded in the rear seat or cargo area of the vehicle, or when vehicle load capacity is exceeded.
- When towing a trailer or other vehicle (AWD models)
- When driving on roads with missing, unclear, discontinued or less detectable lane markers or roads with multiple parallel lane markers, or roads with markings or features that might be detected as lane markers (for example, wheel ruts and paving seams)
- When driving on roads where the lane markers or traffic

- patterns are changing, temporary or unusual (for example, merging or separating lanes, widening/narrowing lanes, exit ramps, toll gates, construction zones, lane closures)
- When the lane markers are not visible due to darkness and the headlights are off
- There are variety of conditions and situations in which the detection of a vehicle ahead may be delayed or the vehicle ahead may not be detected. A few examples include:
 - A vehicle suddenly cuts in front of your vehicle
 - When driving on a blind curve or winding road
 - A stationary vehicle or vehicle travelling at a much slower speed suddenly becomes apparent after the vehicle ahead changes lanes
 - When motorcycles are traveling offset from the center of the lane

- Drivers should always be attentive and take action if needed to manage the roadway and traffic situation.
- The Driver Monitoring System used to support ProPILOT Assist 2.0 may not detect the driver's condition in all situations, including:
 - When the camera or the driver is lit by sunlight or there are repeated changes in brightness (in sunlight and shadow alternatively)
 - When portions of the driver's face or head are hidden (for example, wearing sunglasses, a face mask or a hat)
 - When there is an obstruction between the driver's face and the monitoring camera
 - When the monitoring camera lens becomes dirty or obscured
 - When more than two faces are recognized near the driver's seat (for example, a passenger is leaning over toward the driver)

- When the driver narrows their eyes or loses their driving posture (for example, avoiding the sun glare, etc.)
- The side radar sensors may not detect or may have delayed detection of vehicles in adjacent lanes in some conditions, for example, vehicles approaching rapidly from behind, particularly high or low ground clearance vehicles, motorcycles, or a vehicle which has recently entered that zone from behind. Stay alert to surrounding vehicles and operate the steering wheel as needed for traffic conditions.
- Route Assist may not operate properly when the distance of the exit of junction is extremely short or when driving on a roadway where frequent lane changes are needed near the exit or junction. Stay alert to the surrounding vehicles and operate the steering wheel to proceed to the exit or junction.
- In some conditions, a vehicle or object can unexpectedly come into the sensor detection zone and cause automatic braking. Always stay alert and avoid using

the systems where not recommended.

- Excessive noise will interfere with the warning chime sound and the beep may not be heard.

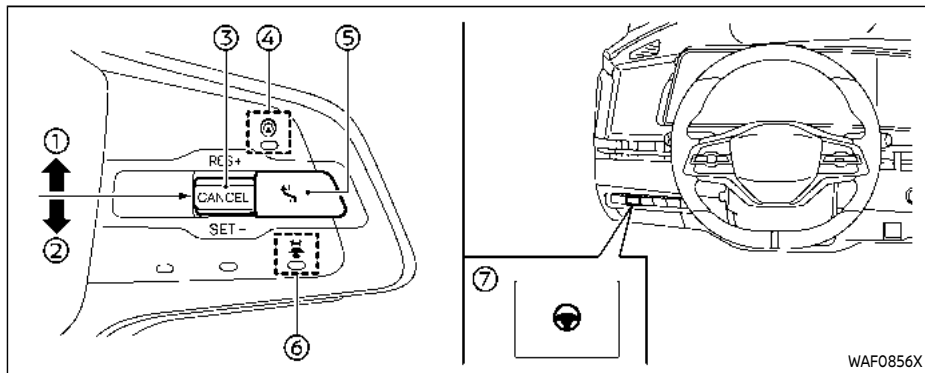

Example

How to operate ProPILOT Assist

NOTE:

All available systems and features are activated simultaneously when ProPILOT Assist is activated.

1. RES+ operation:

Resumes vehicle set speed or increases speed incrementally

2. SET- operation:

Sets desired cruise speed or reduces speed incrementally

3. CANCEL switch:

Deactivates the ProPILOT Assist

4. ProPILOT Assist switch (Ⓞ) or (Ⓞ) :

Turns the ProPILOT Assist on or off

5. Lane Change Assist switch (ProPILOT Assist 2.0):

Accepts or declines a lane change assist suggestion

6. DISTANCE switch:

Adjusts distance to lead vehicle

7. Steering Assist switch:

Turns the Steering Assist function on or off

Turning on ProPILOT Assist (2-step operation):

1. Push the ProPILOT Assist switch (4).
 - The ProPILOT Assist display appears.
 - Safety Shield status screen is temporarily displayed. (See "ProPILOT Assist 2.0" (P.5-96).)

NOTE:

For conventional (fixed speed) cruise control mode, push and hold the ProPILOT Assist switch for more than 1.5 seconds. No other ProPILOT Assist features are available in the conventional (fixed speed) cruise control mode.

2. Once the vehicle is at the desired speed, push down the cancel switch to the SET- direction (2).
 - Vehicle will maintain the set speed unless the vehicle detects a slower vehicle in the traveling lane, or Speed Limit Assist or Speed Adjust by Route is active. (See "Speed Limit Assist" (P.5-103) or "Speed Adjust by Route" (P.5-105).)
 - Once engaged, ProPILOT Assist displays and indicators will appear. (See "ProPILOT Assist displays and indicators" (P.5-94).)

NOTE:

If ProPILOT Assist is in standby (step 1), the vehicle will not brake.

How to adjust distance setting:

Cycle through the desired distance using the distance switch ⑥.

- Distance will vary based on the vehicle speed as this setting is time dependent, not based on gap distance. Example distance is below.

Setting	Distance at 60 MPH (100 km/h)
1 bar	90 ft (30 m)
2 bar	150 ft (45 m)
3 bar	200 ft (60 m)

How to change the vehicle set speed:

To increase speed:

- Push up and hold the cancel switch to the RES+ direction ① to increase speed in 5 MPH (5 km/h) increments.
- Push up and quickly release the cancel switch to the RES+ direction ① to increase speed by 1 MPH (1 km/h).
- Accelerate to new desired speed and press the cancel switch to the SET-direction.

To decrease speed:

- Push down and hold the cancel switch to the SET- direction ② to decrease speed in 5 MPH (5 km/h) increments.
- Push down and quickly release the cancel switch to the SET- direction ② to decrease speed by 1 MPH (1 km/h).

How to momentarily accelerate or decelerate:

- Depress the accelerator pedal when acceleration is required. Release the accelerator pedal to resume to previously set vehicle speed. Vehicle set speed will blink to indicate the vehicle is traveling faster than the set speed.

NOTE:

Hands must be placed on the steering wheel to accelerate in Hands Off mode.

- Depressing the brake pedal when deceleration is required. Doing so will put the system in standby. Push up the cancel switch to the RES+ direction ① to resume to previous set speed.

**WARNING**

When the accelerator pedal is depressed, the ICC system will not provide automatic braking and approach warning. The driver must

manually control the vehicle speed to maintain a safe distance to the vehicle ahead. Failure to do so could result in severe personal injury or death.

How to enable/disable Steering Assist:

Use the following methods to enable or disable Steering Assist:

- Steering Assist switch ⑦
- Vehicle information display
Settings → Driver Assistance → Lane Centering Assist → Steering Assist → ON/OFF

NOTE:

Steering Assist setting will remain even after the EV system is restarted.

How to cancel ProPILOT Assist:

To cancel the ProPILOT Assist, use either of the following methods:

- Push the CANCEL switch ③. This will put the system in standby.
- Tap the brake pedal. This action will keep the system in standby. To resume, push up the cancel switch to the RES+ direction ① to return to the original vehicle set speed, or push down the cancel switch to the SET-direction ② to set the current vehicle speed.

NOTE:

When the ProPILOT Assist is canceled while the vehicle is stopped, the system will automatically apply the parking brake.

WARNING

To prevent the vehicle from moving or rolling unexpectedly, which could result in serious personal injury or property damage, before exiting the vehicle, make sure to push the ProPILOT Assist switch  to turn the system off. Push the P (Park) position switch to shift to the P (Park) position, and turn the EV system off.

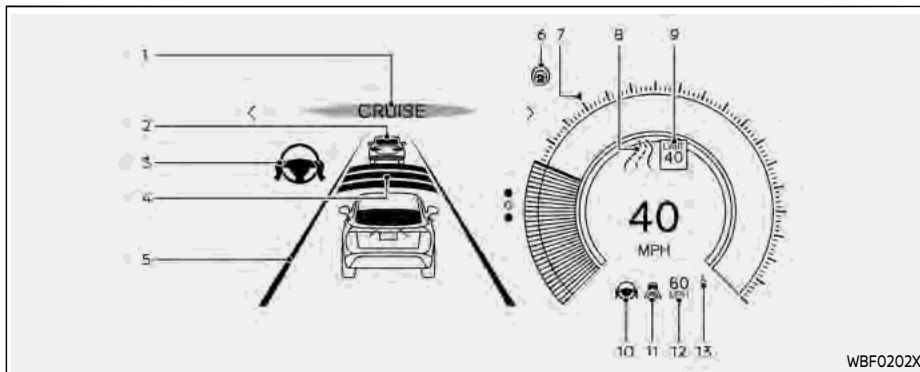

PROPILOT ASSIST DISPLAYS AND INDICATORS

ProPILOT Assist with Navi-link

1. ProPILOT activation

Displays once the ProPILOT Assist system is activated

2. Vehicle ahead detection indicator

Displays whether the system detects a vehicle in front of you (only when ICC is active)

3. Steering Assist indicator

Indicates the status of the Steering Assist function by the color of the indicator

- Steering Assist indicator (gray): Steering Assist standby
- Steering Assist indicator (green): Steering Assist active







4. Set distance indicator

Displays the selected distance

5. Lane marker indicator

Indicates whether the system detects lane markers

- No lane markers displayed: Steering Assist is turned off
- Lane marker indicator (gray): No lane markers detected
- Lane marker indicator (green): Lane markers detected, Steering Assist is

- active
 - Lane marker indicator (yellow): Lane departure is detected
6. **ProPILOT status indicator** ()
- Indicates the status of the ProPILOT Assist system by the color of the indicator
- ProPILOT Assist status indicator (white): ProPILOT Assist is on but in standby
 - ProPILOT Assist status indicator (blue): ProPILOT Assist active
7. **Target speed indicator**
- Indicates the target vehicle speed
- White triangle: Cruise control target speed
 - Green triangle: ICC target speed
8. **Road information indicator (if so equipped)** ( , )
- Indicates the detected road information
9. **Detected road sign (speed limit) indicator (if so equipped)** ()
- Indicates the currently detected speed limit
10. **Steering Assist status indicator/warning** ( , )
- Displays the status of the Steering Assist by the color of the indicator/

warning

- No Steering Assist status indicator displayed: Steering Assist is turned off
 - Steering Assist status indicator (gray): Steering Assist standby
 - Steering Assist status indicator (green): Steering Assist active
 - Steering Assist status indicator (yellow): Steering Assist malfunction
 - Steering Assist status indicator (red): Hands off detected
11. **Speed control status indicator/set distance indicator/lane marker indicator** ()
- Displays the status of speed control by the color of the indicator, and displays the selected distance by the number of horizontal bars shown
- Speed control status indicator (white): ICC standby
 - Speed control status indicator (green): ICC (distance control mode) is active
- Green vehicle icon displayed: Vehicle detected ahead
 - No vehicle icon shown: No vehicle detected ahead (Your vehicle maintains the driver-selected set speed.)

- Speed control status indicator (yellow): Indicates an ICC malfunction

Displays the status of the Steering Assist by the color of the lane marker indicator.

- Lane marker indicator (no lane): Steering Assist is turned off
- Lane marker indicator (gray): Steering Assist standby
- Lane marker indicator (green): Steering Assist active

12. **Vehicle set speed indicator**

Indicates the vehicle set speed

- Green: ICC active
- Gray: ICC standby

The speed unit can be converted between "MPH" and "km/h". (See "Unit/Language" (P.2-31).)

13. **Speed Limit Link indicator (if so equipped)** (, ,)

Indicates the Speed Limit Link activation mode or system operation

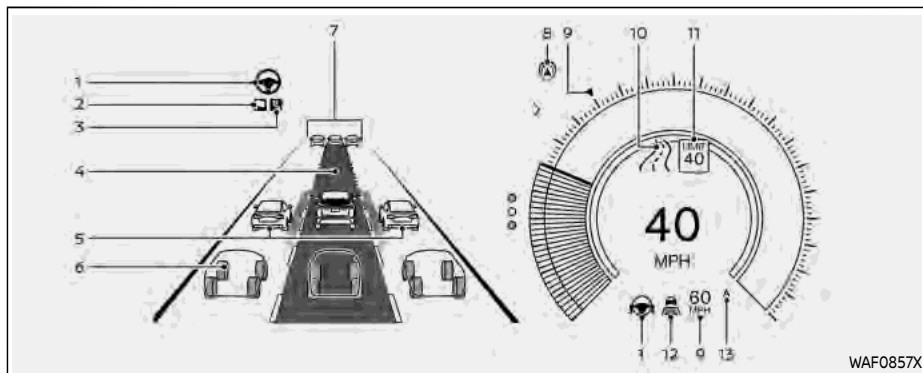

ProPILOT Assist 2.0

NOTE:

Display may vary slightly between ProPILOT Assist type.

Display color will change depending on ProPILOT Assist 2.0 mode.

See "ProPILOT Assist 2.0 mode indicators" (P.5-86).

1. Steering Assist indicator

Indicates the status of the Steering Assist function.

2. Route Assist Indicator (ProPILOT Assist 2.0) ()

Icon is displayed when Route Assist

feature is available.

3. Lane Change Assist Indicator (ProPILOT Assist 2.0) ()

Icon is displayed when Lane Change Assist feature is available.

4. Route Assist display (ProPILOT Assist 2.0)

This image is displayed when Route Assist feature is available.

5. Side detection (ProPILOT Assist 2.0)

Indicates that a vehicle is detected in the side spot.

6. Surrounding Vehicle Display (ProPILOT Assist 2.0)

Displays other detected vehicles, including passenger vehicles, trucks and motorcycles. The multi-lane display is only available on HD* mapped, limited access freeway. (When driving at speeds more than approximately 37 MPH (60 km/h).)

*: HD map data can be used with a subscription service which requires owner consent to activate. The subscription must be active to use these features.

See "License information (ProPILOT Assist 2.0)" (P.5-120).

7. Vehicle ahead detection indicator

Displays whether the system detects a vehicle in front of you.

8. ProPILOT Assist 2.0 status indicator

Indicates the status of ProPILOT Assist 2.0.

9. Vehicle Set Speed Indicator

Indicates the vehicle set speed.

10. Road information indicator (if so equipped) (,)

Indicates the detected road information.

11. Detected road sign (speed limit) indicator (if so equipped) ()

Indicates the currently detected

speed limit.

12. **Intelligent Cruise Control (ICC) Status Indicator**

Displays the status of the speed control including the distance setting and detection of a lead vehicle.

13. **Speed Limit Adjust Indicator (A)**

Indicates the detected speed limit will be automatically applied to the vehicle set speed.

NOTE:

- When the ProPILOT Assist is activated, the display will automatically be switched to the ProPILOT Assist display. To disable this function, turn off in the vehicle information display: Settings → Customize Display → Transition (Cruise).
- The ProPILOT Assist 2.0 display is also shown in the Head Up Display (HUD). (See "Head Up Display (HUD)" (P.2-51).)
- For the license information about HD map data, see "License information (ProPILOT Assist 2.0)" (P.5-120).

Safety Shield Status Screen:

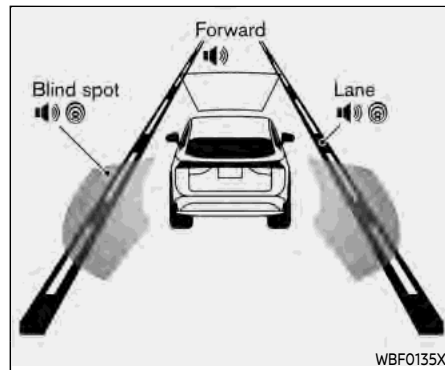

The Safety Shield Status Screen will be displayed after initiating the ProPILOT Assist system, prior to setting the vehicle speed. The display is used to show status of driver assistance features for blind spot, forward driving aids, and side aids. Pressing the ProPILOT Assist switch also activates Intervention systems, if selected in the Driver Assistance settings.



Example (all enabled)

When the Driving Aids are enabled:

Zone	Driving Aid	Display
Forward	Automatic Emergency Braking (AEB) with Pedestrian Detection	Outline
	Intelligent Forward Collision Warning (I-FCW)	
Lane	Lane Departure Warning (LDW)	Outline
	Intelligent Lane Intervention (I-LI)	Shaded
Blind Spot	Blind Spot Warning (BSW)	Outline
	Intelligent Blind Spot Intervention (I-BSI)	Shaded

- When any of the “Warning” systems are enabled, the “” mark is shown in each zone.
- When any of the “Intervention” systems are enabled, the “” mark is shown in each zone.
- When no system is enabled, “OFF” is shown in each zone.

NOTE:

To change the status of the driving aids, use the vehicle information display: Settings → Driver Assistance.

ProPILOT Assist 2.0 modes:

ProPILOT Assist has a variety of modes depending on various conditions and are represented by color. The system will automatically transition to the highest available mode when conditions are met. The table below shows the available system modes and the required conditions.

Mode	Active Systems
OFF	<ul style="list-style-type: none"> • No Systems active – driver initiation required
Gray	<ul style="list-style-type: none"> • No Systems active – driver activation required
White	<ul style="list-style-type: none"> • Intelligent Cruise Control (ICC) active
Green	<ul style="list-style-type: none"> • ICC and Steering Assist active • Driver is holding the steering control
Blue	<ul style="list-style-type: none"> • ICC and Steering Assist active • Driver is paying attention to the traffic and other conditions and laws permit, and it is safe to do so, driver is able to take off their hands from the steering wheel.

NOTE:

If the steering wheel icon is yellow, this indicates that Steering Assist may be limited and should take the driver takes over steering.

INTELLIGENT CRUISE CONTROL (ICC)

Intelligent Cruise Control (ICC) is a part of ProPILOT Assist. Read the entire ProPILOT Assist section before using this system, including how to operate the system and understanding the display. (See “ProPILOT Assist Systems” (P.5-82), “How to operate ProPILOT Assist” (P.5-92) and “ProPILOT Assist displays and indicators” (P.5-94).)

The ICC system uses a forward facing radar sensor and is designed to operate as follows:

- When there is no vehicle detected in the same traveling lane, the ICC system maintains the speed set by the driver.
- When there is a vehicle detected in the traveling lane, the ICC system adjusts the speed to maintain the distance, selected by the driver, from the vehicle ahead. If the vehicle ahead comes to a stop, the vehicle decelerates to a standstill. Once your vehicle stops, the ICC system keeps the vehicle stopped.
- When the vehicle traveling ahead moves to a different traveling lane, the ICC system accelerates and maintains vehicle speed up to the set speed. Maximum speed: 90 MPH (144 km/h)

The ICC system can only apply up to 40% of the vehicle’s total braking power and should only be used when traffic conditions allow vehicle speeds to remain fairly constant. If acceleration is required over the ICC system, the driver may override using the accelerator pedal at any time. The system will not brake the vehicle during driver acceleration. The ICC system requires a lead vehicle if the speed is

below approximately 15 MPH (24 km/h). Vehicle must be traveling at 20 MPH (30 km/h) to initially set the ICC system.

NOTE:

Brake lights of the vehicle come on when braking is performed by the ICC system.

For additional available features of the ICC system, see:

- Speed Adjust by Route (P.5-105) which adjusts speed based on freeway curves, exits and junctions
- Speed Limit Assist (P.5-103) helps alert the driver of a speed limit change and can adjust vehicle set speed

System operation

The ICC system can be set to one of two cruise control modes:

- Cruise control – fixed speed (P.5-102)
- Intelligent Cruise Control – adaptive

NOTE:

Steering Assist is not available in conventional (fixed speed) cruise control.

For Intelligent Cruise Control without Steering Assist, activate ProPILOT Assist and then turn off Steering Assist by the switch or in the settings menu. For additional information, see “How to operate ProPILOT Assist” (P.5-92) and “Steering

Assist” (P.5-106).

For conventional (fixed speed) cruise control, push and hold the ProPILOT Assist switch for longer than approximately 1.5 seconds then set your desired speed. For additional information, see “Conventional (fixed speed) cruise control” (P.5-102).

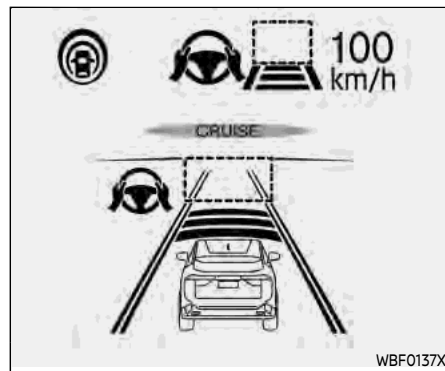

System set display – no vehicle detected ahead (for ProPILOT Assist with Navi-link)



System set display — no vehicle detected ahead (for ProPILOT Assist 2.0)

If no vehicle ahead detected:

The ICC system maintains the vehicle set speed, similar to standard cruise control, as long as no vehicle is detected in the lane ahead.

When a vehicle is no longer detected ahead, the vehicle will gradually accelerate to driver set speed.

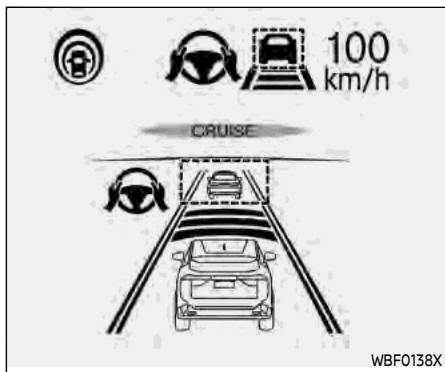

System set display — a vehicle detected ahead (for ProPILOT Assist with Navi-link)



System set display — a vehicle detected ahead (for ProPILOT Assist 2.0)

If vehicle ahead is detected:

When a vehicle is detected in the lane ahead, the ICC system decelerates to the vehicle by controlling the throttle and applying the brakes to match the speed of the slower vehicle ahead and maintain the driver selected distance.

See "How to operate ProPILOT Assist" (P.5-92) for more information.

If the vehicle ahead stops:

When a vehicle ahead is detected and it gradually decelerates to a stop, your vehicle will decelerate to a standstill. When at a standstill, the "(RES+) Follow

Vehicle Ahead” message is displayed on the vehicle information display.

- For vehicles equipped with ProPILOT Assist with Navi-link or ProPILOT Assist 2.0, if the vehicle ahead stops and your vehicle is stopped less than approximately 30 seconds on the freeway, the “Follow Vehicle Ahead” message appears on the vehicle information display. When the vehicle ahead begins to move, your vehicle will start moving automatically.
- If not equipped with these systems, or not on a freeway, your vehicle will automatically start moving after 3 seconds.

To resume the ICC system after stop, push up the cancel switch to the RES+ direction or lightly depress the accelerator pedal.



WARNING

If a vehicle cuts in after your vehicle was stopped by the ICC system, it cannot be detected depending on its position or direction. Your vehicle may approach the cut-in vehicle when restarting. Operate the brake pedal to maintain a safe distance to the vehicle ahead.

Cut-in detection:

For vehicles not equipped with ProPILOT Assist 2.0, if a vehicle moves into your traveling lane near your vehicle, the ICC system may inform the driver by flashing the vehicle ahead detection indicator.

Passing a slower vehicle:

When passing a slower vehicle on the left, the ICC system will temporarily accelerate to aid in the lane change. The system will not exceed set speed during a lane change.

Approach warning:

If your vehicle comes closer to the vehicle ahead due to rapid deceleration of that vehicle or if another vehicle cuts in, the system warns the driver with the chime and ICC system display. Decelerate by depressing the brake pedal to maintain a safe vehicle distance if:

- The chime sounds.
- The vehicle ahead detection indicator blinks.
- You judge it necessary to maintain a safe distance.

The warning chime may not sound in some cases when there is a short distance between vehicles. Some examples are:

- When the vehicles are traveling at the same speed and the distance between vehicles is not changing.
- When the vehicle ahead is traveling faster and the distance between vehicles is increasing.

NOTE:

The approach warning chime may sound and the system display may flash when the radar sensor detects objects on the side of the vehicle or on the side of the road. This may cause the ICC system to decelerate or accelerate the vehicle. The radar sensor may detect these objects when the vehicle is driven on winding, narrow, or hilly roads or when the vehicle is entering or exiting a curve. In these cases, you will have to manually control the proper distance ahead of you vehicle. Also, the sensor sensitivity can be affected by vehicle operation (steering maneuver or driving position in the lane) or traffic or vehicle conditions (for example, if a vehicle is being driven with some damage).

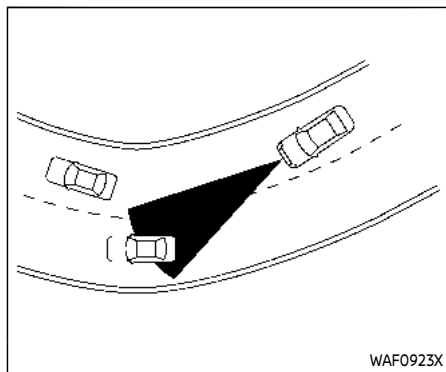

NOTE:

It is important to ensure the radar sensors, cameras and sonar sensors are clean before each drive. Unclean or damaged cameras and sensors, as well as environmental conditions can affect system performance. See "Driver assistance troubleshooting guide" (P.5-36) for more information.

Warnings and malfunctions

Under the following conditions, the ICC system is automatically canceled. A chime will sound and the system will not be able to be set:

- The vehicle ahead is not detected and your vehicle is traveling below the speed of 15 MPH (24 km/h). For ProPILOT Assist with Navi-link equipped vehicles on a limited access freeway as identified in the navigation map data, the ICC system cancels and a warning chime sounds if your vehicle is at a standstill for more than approximately 3 seconds and a vehicle is not detected ahead.
- Any door is open.
- The driver's seat belt is unfastened.
- Your vehicle has been stopped by the ICC system for approximately 3 minutes or longer.
- The shift lever is moved out of the D (Drive) or B position.
- The electronic parking brake is applied.
- The SNOW mode is selected (AWD models).
- The VDC system is turned off.
- The VDC system (including the traction control system) operates.
- A wheel slips.
- The AEB with Pedestrian Detection applied harder braking.
- When the radar signal is temporarily interrupted.

If limitations are considered, all conditions

above are met and the ICC system is still not functioning properly, see "Driver assistance troubleshooting guide" (P.5-36) for full list of messages and conditions.

CONVENTIONAL (fixed speed) CRUISE CONTROL

Conventional (fixed speed) cruise control is available as an alternative to Intelligent Cruise Control. To turn on conventional cruise control mode:

1. Push and hold the ProPILOT Assist switch  for longer than approximately 1.5 seconds.

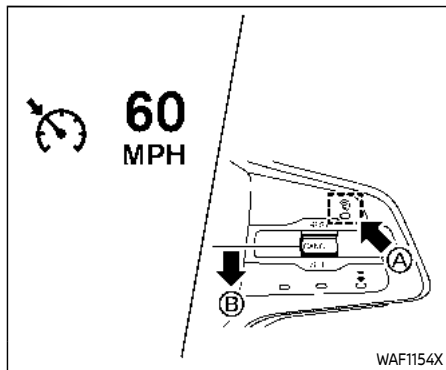

2. Once vehicle is at the desired speed, push down the cancel switch to the SET- direction **B**.

Once set, the vehicle will maintain the desired set speed as shown by the cruise control icon and set speed indicator displayed above.

For complete detail on the operation of conventional (fixed speed) cruise control, see "How to operate ProPILOT Assist" (P.5-92).

NOTE:

No other ProPILOT Assist features are available in conventional (fixed speed) cruise control mode. To use the ICC system again, cancel the system (if

necessary) and quickly push and release the ProPILOT Assist switch.

⚠ WARNING

To avoid accidentally engaging cruise control, make sure to turn the ProPILOT Assist switch off when not using the ICC system.

SPEED LIMIT ASSIST

Speed Limit Assist is a feature of ProPILOT Assist Systems on vehicle equipped with a built-in navigation system. Read the entire ProPILOT Assist and Traffic Sign Recognition sections before using this system.

When ProPILOT Assist with Navi-link (or 2.0) is active and it detects a change of the speed limit, the new speed limit is indicated and it can be applied to the vehicle set speed automatically or manually. The Speed Limit Assist operates:

- When the detected speed limit is 20 MPH (30 km/h) and above.
- The "Speed Limit Assist" is enabled in the settings menu of the vehicle information display.

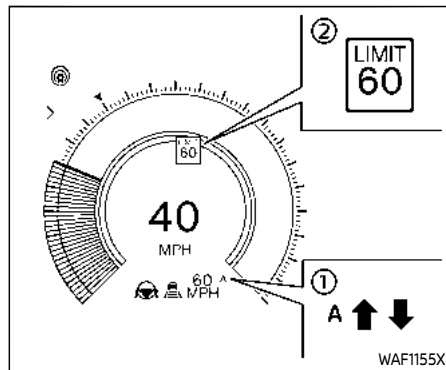

Speed Limit Assist has two modes and is shown in the display **1**.

Setting	Speed Limit
Auto (A)	Automatically adopted
Manual	Request to accept
Offset (for ProPILOT Assist 2.0)	Adds/Subtracts 0-5 MPH (0-10 km/h)
OFF	Feature is OFF

The Auto mode may not be available in some regions or on roads other than limited access freeways. In this case, the system operates as the Manual mode.

NOTE:

- **Auto mode will not function in Hawaii or US island territories.**
- **Auto mode is only available on limited access freeways as identified in the navigation map data.**

When the system detects a different speed limit by the Traffic Sign Recognition (TSR) system, the new speed value is displayed in ②.

When in Manual mode (factory default setting for ProPILOT Assist with Navilink):

- To accept a newly indicated speed limit, operate the cancel switch to the RES+ direction for a speed limit increase or the SET- direction for a speed limit decrease.
- The speed limit can be rejected by operating the opposite switch from the direction indicated by the Speed Limit Assist indicator.
- If no action is taken, the set speed will remain the same.
- If speed limit offset is on, this value will be added or subtracted from speed limit (for ProPILOT Assist 2.0).

When in Auto mode (factory default setting for ProPILOT Assist 2.0):

- The indicated speed limit is applied to the vehicle set speed automatically.
- If speed limit offset is on, this value will be added or subtracted from speed limit (for ProPILOT Assist 2.0).
- If ProPILOT Assist is on (standby), but not set (active), and new speed limit is detected, the vehicle set speed is automatically updated.

How to adjust Speed Limit Offset (for ProPILOT Assist 2.0):

Vehicle information display

Settings → Driver Assistance → Intelligent Cruise → Speed Limit Assist Set → -5MPH (-10 km/h) to + 5MPH (10 km/h)

How to enable/disable/change Speed Limit Assist:

Vehicle information display

Settings → Driver Assistance → Intelligent Cruise → Speed Limit Assist → Auto/Manual/OFF

NOTE:

- **While the accelerator pedal is operated with Auto mode selected, Speed Limit Assist will function (automatically adjust the vehicle set speed) only when the detected speed limit is faster than the vehicle**

set speed.

- **In the following situations, Speed Limit Assist will not operate:**
 - **When an increase in the posted speed limit is detected, but the vehicle set speed is already faster than the new speed limit.**
 - **When a decrease in the posted speed limit is detected, but the vehicle set speed is already lower than the new speed limit.**

**WARNING**

Listed below are the system limitations for Speed Limit Assist. Failure to operate the vehicle in accordance with these system limitations could result in serious injury or death. It is driver's responsibility to select the proper speed, follow all traffic regulations and observe other road users.

- **Speed Limit Assist may not operate properly and the actual speed limit may not be applied to the vehicle set speed in all conditions. The driver must manually control the vehicle speed.**

Below are some examples:

– When the Traffic Sign Recognition (TSR) system is not functioning properly or turned off. (See “Traffic Sign Recognition (TSR)” (P.5-40).)

When speed limit sign is faded, dirty or distorted.

– When driving in countries or areas not covered by the navigation system.

– When crossing national boundaries.

– When driving on the exit of the limited access freeway as identified in the navigation map data.

– When driving in an area with nearby parallel roads (for example, freeway with a parallel service drive).

– When driving in an area where each lane has a different speed limit sign.

– When driving on a road under construction or in a construction zone.



– When the data from the navigation system is not up-to-date or is unavailable.

SPEED ADJUST BY ROUTE

Speed Adjust by Route is a feature of ProPILOT Assist Systems on vehicles equipped with a built-in navigation system. Read the entire ProPILOT Assist section before using this system, including how to operate the system and understanding the display. (See “ProPILOT Assist Systems” (P.5-82), “How to operate ProPILOT Assist” (P.5-92) and “ProPILOT Assist displays and indicators” (P.5-94).)

When ProPILOT Assist with Navi-link is active on a limited access freeway (as identified in the navigation map data), Speed Adjust by Route uses road information provided by the navigation system and can adjust the vehicle speed depending on curves, junctions and exits. The system may not always reduce speed for all curves, junctions or exits and the driver may need to apply additional braking at any time. When the vehicle is through the curve or junction, the vehicle will accelerate again to the set speed. When exiting the limited access freeway, the driver will need to apply braking at the end of the exit.

When Speed Adjust by Route is active, either icon will appear in the vehicle information display.

	Curves and junctions
	Exits

How to enable/disable Speed Adjust by Route:

Vehicle information display

Settings → Driver Assistance → Intelligent Cruise → Speed Adjust by Route → ON/OFF

NOTE:

- The system does not operate when the accelerator pedal is depressed.
- The system may not operate depending on the set distance to the vehicle ahead.
- The system will retain current settings in the vehicle information display even if the EV system is restarted.



WARNING

Listed below are the system limitations for Speed Adjust by Route. Failure to operate the vehicle in accordance with these system lim-

itations could result in serious injury or death:

- There are limitations to Speed Adjust by Route system capability. The system does not function in all driving, traffic, weather and road conditions. It is the driver's responsibility to stay alert, drive safely, and be in control of the vehicle at all times.
- Speed Adjust by Route does not brake the vehicle to a stop. Whenever necessary, the driver must apply appropriate braking.
- It is the driver's responsibility to select the proper speed, follow all traffic regulations and observe other road users.
- Speed Adjust by Route will not function in Hawaii or US island territories.
- Speed Adjust by Route may not operate properly in some road and traffic conditions, and the system may unexpectedly change the speed. The driver must manually control the vehicle speed.

Below are some examples:

- When the data from the navigation system is not up-to-date or is unavailable.
- When not driving along the route suggested by the navigation system.
- When the navigation system is recalculating the route.
- When driving in countries or areas not covered by the navigation system.
- When driving on a road under construction or newly constructed road.
- When driving near a road split or junction.
- When driving in bad weather or poor road conditions.

STEERING ASSIST

Steering Assist is a part of ProPILOT Assist Systems. Read the entire ProPILOT Assist section before using this system, including how to operate the system and understanding the display. (See "ProPILOT Assist Systems" (P.5-82), "How to operate ProPILOT Assist" (P.5-92) and "ProPILOT Assist displays and indicators" (P.5-94).)

Steering Assist uses a forward facing

camera to detect clear and consistent lane markings on both sides of the vehicle and is designed to help keep the vehicle in the center of traveling lane. Steering Assist is only available when combined with the Intelligent Cruise Control (ICC) system making up ProPILOT Assist.

Steering Assist can be activated when the following conditions are met:

- ProPILOT Assist is activated.
- Lane markings on both sides are clearly detected.
- Your vehicle is traveling at speed over 37 MPH (60 km/h), or a vehicle is detected in front of you when traveling under 37 MPH (60 km/h).
- The driver has hands on the steering wheel.
- The vehicle is driven at the center of the lane.
- Turn signals are not active.
- The windshield wipers are not operated in the high speed position.

When a curve or strong cross wind exceeds the capabilities of the system and your vehicle approaches the lane line, the Intelligent Lane Intervention (I-LI) system will activate. The I-LI system will have a visual and audible alert while applying the brakes for a short period of time to help assist the driver to return to

the center of the lane. For more information, see "Intelligent Lane Intervention (ILI)" (P.5-49).

How to enable/disable Steering Assist:

Use the following methods to enable or disable Steering Assist:

- Steering Assist switch (located on the left side of the instrument panel as shown in the diagram. See "How to operate ProPILOT Assist" (P.5-92).)
- Vehicle information display
Settings → Driver Assistance → Lane Centering Assist → Steering Assist → ON/OFF

NOTE:

Steering Assist setting will remain even after the EV system is restarted.

NOTE:

It is important to ensure the radar sensors, cameras and sonar sensors are clean before each drive. Unclean or damaged cameras and sensors, as well as environmental conditions can affect system performance. See "Driver assistance troubleshooting guide" (P.5-36) for more information.

Hands on detection

When Steering Assist is activated, the vehicle monitors the driver's steering wheel operation using a capacitive and torque sensor in the steering wheel. When ProPILOT Assist displays in hands on (green) mode, if the steering wheel is not operated or if the driver takes their hands off the steering wheel for a period of time, the warning ① appears and the hands off warning light ② illuminates. See table on the next page for escalating warnings if the system does not detect drivers hands on the wheel.

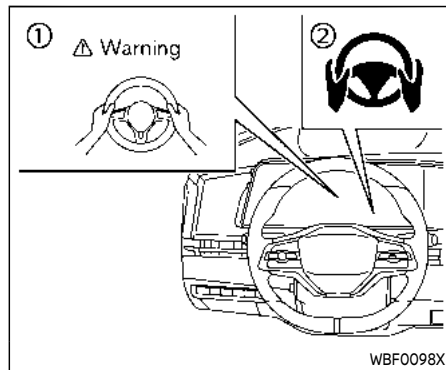

Hands on may be required for other ProPILOT Assist 2.0 features, where the hands on detection function also operates. These functions include Lane Change Assist, Passing Assist or Route Assist as described, while easy assist is operating. (See "Lane Change Assist" (P.5-113), "Passing Assist" (P.5-115) or "Route Assist" (P.5-118).)

NOTE:

The system may not detect the driver's hand(s) on the steering wheel in the following conditions:

- When the driver is wearing gloves.
- When a cover is put on the steering wheel.

- **When the driver grips the seam of leather or spokes on the steering wheel.**
- **If hands are not detected by touch, it is recommended to provide steering torque.**

HANDS ON DETECTION

In Hands On (green) mode, the vehicle uses capacitive and torque sensors in the steering wheel to detect whether the driver has their hands placed on the steering wheel. It is the driver's responsibility to have hands on the wheel in order to avoid these increasing alerts.

First Warning	<ul style="list-style-type: none">● Message appears in the vehicle information display alerting driving that hands are not detected.● Driver must place their hands back on the steering wheel or apply light torque to the steering wheel to clear the message.
Second Warning	<ul style="list-style-type: none">● Message begins to flash with escalating beeping sounds to draw driver's attention.● Driver must place their hands back on the steering wheel or apply light torque to the steering wheel to clear the message.
Third Warning	<ul style="list-style-type: none">● The vehicle will apply 2 brake pulses to alert the driver of failure to comply.● Driver must place their hands back on the steering wheel or apply light torque to the steering wheel to clear the message.
Emergency Stop	<ul style="list-style-type: none">● Emergency warning sound will play and a "Manually Steer" or "Take Steering Control" and/or "Slowing to Stop" warning message will display.● The vehicle will gradually slow vehicle to a complete stop in the traveling lane and the hazard indicator lights will automatically activate when the vehicle reaches approximately 40 MPH (65 km/h).● Driver must place their hands back on the steering wheel or apply light torque to the steering wheel to deactivate the emergency stop.

Steering Assist with HD map data (a feature of ProPILOT Assist 2.0)

On ProPILOT Assist 2.0 equipped vehicle, the ProPILOT Assist 2.0 mode indicator turns blue when the condition is met.

When ProPILOT Assist 2.0 activates with blue indicators, traffic and other conditions and laws permit, and it is safe to do so, your hands can be taken off the steering wheel. Always pay attention to the road and the operation of the vehicle.

The driver can override with manual steering at any time. When ProPILOT Assist 2.0 is active, always be prepared to take immediate steering and braking.

For ProPILOT Assist 2.0 activates with blue indicators, the following conditions must be met. The system may also cancel if any of these conditions are no longer met.

- ProPILOT Assist is active and the driver's hands are detected on the steering wheel.
- The vehicle is driving on a highway or limited access freeway as defined by the HD map data.
- Camera, radar, and GNSS sensors are functioning and free from obstruction or damage.

- The driver monitor system detects the driver's attention is given to the road ahead.
- All driving, road, and traffic conditions allow.
- Lane markings are clearly visible and able to be detected by the system.
- The vehicle is traveling at a speed less than 85 MPH (137 km/h).



WARNING

It is the drivers responsibility to always drive in a legal manner and obey all local and state regulations.

Some local and state regulations may require hands to be kept on the steering wheel at all times. Only remove hands from the steering wheel it is safe to do so, and it is permitted by local and state regulations.

How to enable/disable Hands Off mode:

Vehicle information Display

Settings → Driver Assistance → Lane Centering Assist → Hands Off Mode → ON/OFF



WARNING

Immediately hold the steering wheel when the ProPILOT Assist 2.0 display changes to green. (See "Hands on detection" (P.5-107).)

Steering Assist with HD map data is not available or may cancel if any of the following conditions are met, but not limited to:

- When the vehicle approaches the area near a toll gate, exit, junction, sharp curve, intersection or where the traveling lane merges.
- When the vehicle approaches an area that is not considered a highway or limited access freeway as defined by the HD map data, the HD map data is not available, or the system detects that the HD map data does not match the current roadway.
- When there is no reception of GNSS signals, including tunnels.
- When driving on a road not separated from the opposite lane.
- When depressing the accelerator pedal or actively using the steering wheel.
- A construction zone.

- When the driver monitor camera cannot recognize that the driver is driving with careful attention to the front.
- When the driver's face is not directed toward the road even if the gaze is directed forward.
- When the driver's face cannot be seen correctly from the camera installed on the steering column. It may occur when the face is blocked by the hand or when the driver is in a driving posture where the position of the face is difficult to see from the camera.
- When the shape of the mouth, nose, or face cannot be clearly seen due to wearing a mask, glasses, sunglasses, etc.
- When the driver narrows his or her eyes due to bright sunlight, etc.
- The windshield wipers are operated in any mode other than intermittent.
- The AEB with Pedestrian Detection and/or Lane Departure Warning (LDW) system activates.

NOTE:

For the license information about HD map data, see "License information (ProPILOT Assist 2.0)" (P.5-120).

DRIVER MONITOR

ProPILOT Assist 2.0 monitors the driver's attention to the road ahead with a driver facing camera, located on the steering column. The system is looking for head position and direction, eye opening, and eye direction. If the system does not detect driver's attention on the road, a series of warnings will display in an effort to draw the driver's attention back forward.

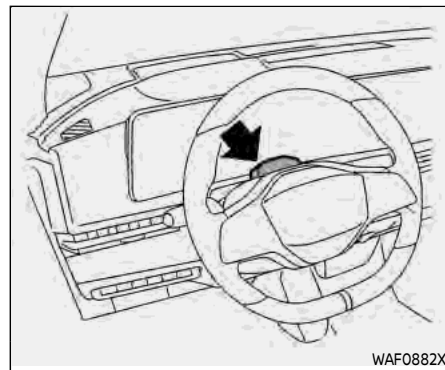

NOTE:

The driver monitor is active in all driving modes, not just when ProPILOT Assist 2.0 is active.

License information

The driver monitoring system includes software using open source software (OSS). License information can be found on the website below.

http://www.embedded-carmultimedia.jp/RTOS/License/oss/DMS_0401/

ATTENTION TO THE ROAD

On ProPILOT Assist 2.0 equipped vehicles, the vehicle uses a camera-based driver monitor system to determine if the driver is monitoring the road ahead. It is the driver's responsibility to pay attention in order to avoid these increasing alerts:

First Warning	<ul style="list-style-type: none">● A beep and a message will appear to draw driver's attention toward the road.● Driver must look ahead to clear the message.
Second Warning	<ul style="list-style-type: none">● The message changes and request to hold the steering wheel.● Message flashes with escalating beeping sounds to draw driver's attention.● Driver must place their hands back on the steering wheel or apply light torque to the steering wheel to clear the message.
Third Warning	<ul style="list-style-type: none">● Vehicle will apply 2 brake pulses to alert the driver of failure to comply.● Driver must place their hands back on the steering wheel or apply light torque to the steering wheel to clear the message.
Emergency Stop	<ul style="list-style-type: none">● Emergency warning sound will play and a "Manually Steer" and/or "Slowing to Stop" warning message will display.● The vehicle will gradually slow to a complete stop in the traveling lane and the hazard indicator lights will automatically activate when the vehicle reaches approximately 40 MPH(65 km/h).● Driver must place their hands back on the steering wheel or apply light torque to the steering wheel to deactivate emergency stop.

LANE CHANGE ASSIST

Lane Change Assist is a feature of ProPILOT Assist 2.0. Read the entire ProPILOT Assist section before using this system, including how to operate the system and understanding the display. (See "ProPILOT Assist Systems" (P.5-82), "How to operate ProPILOT Assist" (P.5-92) and "ProPILOT Assist displays and indicators" (P.5-94).)

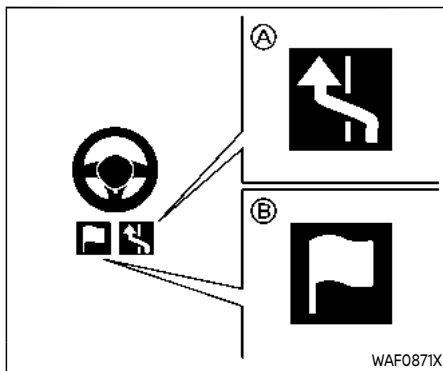

When ProPILOT Assist is active and the status indicator (A) and Route Assist indicator (B) are illuminated in blue, Lane Change Assist helps the driver make a lane change when the turn signal is activated. The driver must place their hands on the steering wheel prior to the lane change maneuver and ensure safety throughout the lane change.

The Lane Change Assist status indicator will illuminate under the following conditions:

- When the ProPILOT Assist 2.0 display is blue (hands-off mode).
- When driving at speeds more than approximately 37 MPH (60 km/h).

- When driving on a road where there are more than two lanes.
- When either right or left, or both target lanes the vehicle moves to has dotted-white lines.
- When driving on a straight road or road with a gentle curve.
- When driving on a road where the speed limit is 45 MPH (70 km/h) or higher.
- When either the "Route Assist", "Activate by turn signal" or "Passing Assist" is enabled.

Lane Change Assist may cancel or not be available under the following conditions:

- When driving on the road where there is a new junction or exit, which is not identified in the navigation map.
- When the "Lane Change Assist" is disabled in the settings menu of the vehicle information display (even if the Lane Change Assist status indicator illuminates in blue).
- When another vehicle is detected in the target lane.
- When lane markers are not longer detected.
- When the vehicle speed is below approximately 37 MPH (60km/h).

- When the driver's hands are not detected on the steering wheel.
- When the ICC system/ProPILOT Assist is cancelled.
- When a shield is found near the lane marker in the direction of the target lane.

How to enable/disable Lane Change Assist:

Vehicle information Display

Settings → Driver Assistance → Lane Change Assist → Activate by turn signal → ON/OFF



WARNING

Failure to follow the warnings and instructions for proper use of Lane Change Assist could result in serious injury or death.

- **Lane Change Assist only assists the driver to make a Lane change. The system does not steer the vehicle to avoid a collision. Be sure to keep your hands on the steering wheel and move safely to a different lane.**

NOTE:

The steering operation by the driver is always prioritized. If the driver's hands are not detected, it warns the driver to place their hands on the steering wheel. If hands are not detected in a timely manner, the Lane Change Assist feature may not be cancelled.

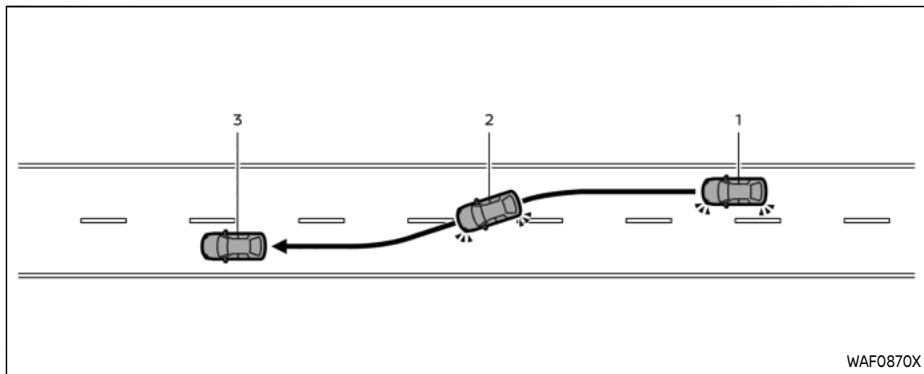

- When the vehicle speed is below approximately 37 MPH (60km/h).
- When the driver's hands are not detected on the steering wheel.
- When the ICC system/ProPILOT Assist is canceled.
- When the lane markers in both lanes are not dotted-white lines.
- When a shield is found near the lane marker in the direction of the target lane.
- When the Lane Change Assist operation is stopped within the lane where the system starts to operate, the system will control the steering wheel to return the vehicle to the center of the lane.

Limitations

For system limitations, see "Limitations" (P.5-88).

PASSING ASSIST

Passing Assist is a feature of ProPILOT Assist 2.0. Read the entire ProPILOT Assist section before using this system, including how to operate the system and understanding the display. (See "ProPILOT Assist Systems" (P.5-82), "How to operate ProPILOT Assist" (P.5-92) and "ProPILOT Assist displays and indicators" (P.5-94).) Passing Assist also uses Lane Change

System operation

Before starting a lane change, ensure that the target lane is clear and it is safe to move into the lane.

1. Hold the steering wheel and activate the turn signal in the direction of moving.
2. The Lane Change Assist display appears and flashes green, and the system starts to assist the vehicle moving to the target lane by steering control.
3. When the lane change is completed, the turn signal cancels automatically*1. Then Steering Assist operates again.

*1 If the turn signal lever was moved up or down fully to activate, the turn signal will not cancel automatically. (See "Turn signal switch" (P.2-68).)

The Lane Change Assist operation will be stopped (the Lane Change Assist display turns off):

- When the turn signal is operated to the opposite direction.
- When the steering wheel is operated.
- When a vehicle is detected in the target lane.
- When the lane markers are no longer detected.

Assist features. (See "Lane Change Assist" (P.5-113) for details.)

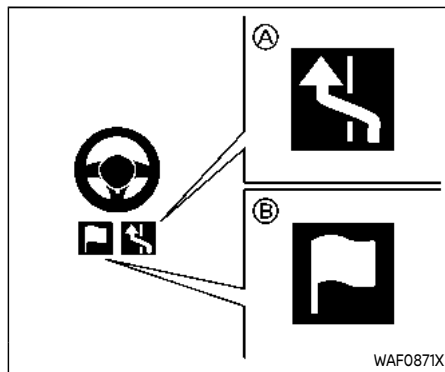

When ProPILOT Assist is active and the status indicator (A) and Route Assist indicator (B) are illuminated in blue, Passing Assist will help the driver to overtake a slower vehicle by:

1. Notifying the driver of slower vehicle by suggesting to pass on the left when no vehicles are detected in blind spot.

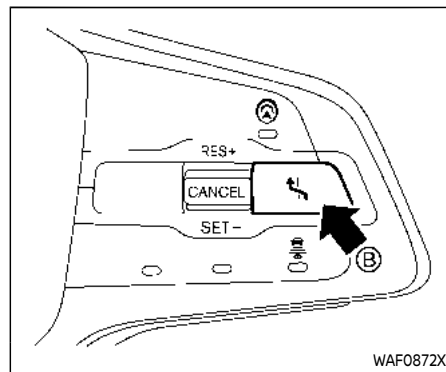

2. Assist in lane change with Lane Change Assist after the driver's acceptance by the Lane Change Assist switch (B) on the steering wheel.



WARNING

Driver is responsible to move out of passing lane as laws require.

All conditions must be met in order for Passing Assist to operate:

- ProPILOT Assist must be active
- The Lane Change Assist status indicator illuminates in blue (See "Lane

Change Assist" (P.5-113) for conditions)

- No vehicle is detected in the intended lane
- Lane markers are detected
- Vehicle speed is above approximately 37 MPH (60 km/h)
- Driver's hands must be detected on the steering wheel
- Passing Assist is enabled

The vehicle will suggest to pass when the slower lead vehicle is detected traveling at the following speeds:

Setting	Lead vehicle speed
Sport	3 MPH + (5 km/h) slower
Standard	6 MPH + (10 km/h) slower
Comfort	9 MPH + (15 km/h) slower

NOTE:

The steering operation by the driver is always prioritized.

How to enable/disable Passing Assist:

Vehicle information display

Settings → Driver Assistance → Lane Change Assist → Passing Assist → ON/OFF

How to change Passing Assist mode:

Settings → Driver Assistance → Lane Change Assist → Passing Setting → Sport/Standard/Comfort

System operation

1. When a slower vehicle is detected ahead, the message "Slow Vehicle Ahead  Change Lanes Left" appears.
2. Ensure that it is safe to move into the left lane, hold the steering wheel and push the Lane Change Assist switch on the steering wheel.
 - **If the blind spot is clear**, the vehicle will proceed to step 3.
 - **If a vehicle is detected in the blind spot**, the system will search for a space for approximately 30 seconds. If no space is created in this time, the system will cancel.
 - **If the driver's hands are not detected on the steering wheel, the system will issue a warning.** If their hands are not placed on the steering wheel in a timely manner, Lane Change Assist may cancel.
3. The Lane Change Assist display flashes green and the turn signal is activated automatically (if not activated by the driver). The system starts to assist the vehicle moving into the left lane by steering control.
4. When the lane change is completed, the turn signal cancels automatically. Then Steering Assist operates again.

5. Hands off (blue) mode will resume as soon as conditions are met.

To stop Passing Assist operation:

The Passing Assist operation will be stopped (the Lane Change Assist display turns off):

- When the turn signal is operated in the opposite direction of the lane change.
- When the steering wheel is operated.
- When open space in the adjacent lane cannot be detected within approximately 10 seconds after pushing the Lane Change Assist switch.
- When a vehicle is detected in the target lane after the turn signal is operated.
- When the lane markers are not longer detected.
- When the vehicle speed is below approximately 37 MPH (60km/h).
- When the driver's hands are not detected on the steering wheel.
- When the ICC system/ProPILOT Assist is canceled.
- When the vehicle to be overtaken accelerates or changes lanes
- When the vehicle reaches the lane change point required to drive according to the navigation route

- When a shield is found near the lane marker in the direction of the target lane after the turn signal is operated.

The turn signal also cancels automatically after the Passing Assist operation is stopped. When the Passing Assist operation is stopped within the lane where the system starts to operate, the system will assist the driver to return the vehicle to the center of the lane.

Limitations

For system limitations, see "Limitations" (P.5-88).

ROUTE ASSIST

Route Assist is a feature of ProPILOT Assist 2.0. Read the entire ProPILOT Assist section before using this system, including how to operate the system and understanding the display. (See "ProPILOT Assist Systems" (P.5-82), "How to operate ProPILOT Assist" (P.5-92) and "ProPILOT Assist displays and indicators" (P.5-94).) Route Assist also uses Lane Change Assist features. (See "Lane Change Assist" (P.5-113) for details.)

Route Assist helps notify the driver of a required upcoming lane change according to the route set in the navigation system. The following conditions must be met for Route Assist to operate:

1. ProPILOT Assist 2.0 must be active with a route set in the in-vehicle navigation system.
2. The Lane Change Assist status indicator and Route Assist indicator are illuminated in blue. (See "Lane Change Assist" (P.5-113) for conditions.)

To accept the suggest lane change, push the Lane Change Assist switch on the steering wheel.

Route Assist will suggest a lane change to follow route in the following scenes:

- Current lane merges/ends
- Approaching exit
- Approaching junction
- Lane change in preparation for above scenarios

NOTE:

- **The system will prompt the driver approximately 1.2 miles (2 km) prior for every required lane change.**
- **When necessary to change lanes more than twice continuously, a zigzag image extending to the desired lane and a number of times indicating the remaining lane changes will be displayed on the screen.**

How to enable/disable Route Assist:

- When the vehicle is necessary to change lanes more than twice continuously, a zigzag image extending to the desired lane and a number of times indicating the remaining lane changes will be displayed on the screen.

Vehicle information display

Settings → Driver Assistance → Lane Change Assist → Route Assist → ON/OFF

How to change Route Assist Mode setting:

Vehicle information display

Settings → Driver Assistance → Lane Change Assist → Route Assist Mode → Once/Everytime

If multiple lane changes are required, the driver can accept all lane changes with one approval or one lane change at a time based on the Route Assist Mode setting.

NOTE:

- **The steering operation by the driver is always prioritized.**
- **Hands must be placed on the steering wheel during the Lane Change Assist operation.**

System operation

1. When a lane change is required to follow set route, a chime will sound and a message will appear.
2. To accept, ensure that it is safe to move into the target lane, hold the steering wheel and push the Lane Change Assist switch on the steering wheel.
3. The Lane Change Assist display will flash green and the turn signal is activated automatically (if not activated by the driver). The system will attempt to assist and maneuver into the target lane by steering control.
4. When the lane change is completed, the turn signal cancels automatically. Then Steering Assist operates again and will resume to hands off (blue) mode when conditions are met.

NOTE:

If the target lane is too congested or the lane change cannot be made in the time required, the system will chime and a message "Lane Change Assist Canceled" appears. It is necessary for the driver to complete the lane change in order to stay on route.

To stop Route Assist operation:

The Route Assist operation will be stopped (the Lane Change Assist display turns off):

- When the Lane Change Assist switch is pushed and held.
- When the turn signal is operated to the opposite direction.
- When the steering wheel is operated.
- After pushing the Lane Change Assist switch, when the vehicle approaches an exit/branch road or a point where the number of lanes decreases without detecting the space where the lane can be changed.
- When a vehicle is detected in the target lane after the turn signal is operated.
- When the lane markers are no longer detected.
- When the vehicle speed is below approximately 37 MPH (60km/h).
- When the driver's hands are not detected on the steering wheel.
- When the ICC system/ProPILOT Assist is canceled.
- When a new route is presented by the navigation system and the vehicle no longer needs to change lanes according to the route.

The turn signal also cancels automatically

after the Route Assist operation is stopped. When the Route Assist operation is stopped within the lane where the system starts to operate, the system will assist the driver to return the vehicle to the center of the lane.

Limitations

For system limitations, see "Limitations" (P.5-88).



WARNING

Under the following conditions, Route Assist will not operate properly. Stay alert to the surrounding vehicles and operate the steering wheel to proceed to the exit or junction:

- **When the distance of the exit or junction is extremely short.**
- **When driving on the road where frequent lane changes are necessary near the exit or junction.**

LICENSE INFORMATION (ProPILOT Assist 2.0)

3D HD MAP data process includes software using open source(OSS) and algorithm. The license information is printed in the web sites below.

http://www.embedded-carmultimedia.jp/RTOS/License/oss/HDL_0101/

http://www.embedded-carmultimedia.jp/RTOS/License/oss/HDL_0102/

http://www.embedded-carmultimedia.jp/RTOS/License/lib/HDL_0121/

License information of 3D HD MAP data is as follows:

TERMS OF USE OF USHR INC. MATERIAL AND AGREEMENT TO END USER SUB-LICENSE AGREEMENT

This vehicle contains data, software, Intellectual Property or a portion thereof, and Confidential Information or a portion thereof that is incorporated into the driver assistance systems of this vehicle and which is subject to a license with Ushr Inc. (the "Ushr Materials"). Any use of the Ushr Materials or systems incorporating them constitute your agreement to these Terms of Use and to the terms and conditions of the End User Sub-License Agreement as fully stated on Ushr Inc.'s website, available at www.ushrauto.com/legal and which are expressly incorporated into 5-120 **Starting and driving**

rated by reference herein. If you do not agree to these Terms of Use and to the End User Sub-License Agreement ("license"), do not use the Ushr Materials. The license affects your legal rights and relates to the following, among other things, your agreement to abide by the permissions and prohibitions as to the use of the Ushr Materials; that the Ushr Materials are provided on an AS IS basis and WITHOUT WARRANTY OF ANY KIND; Ushr's limitations on liabilities, Ushr's reservation of all rights in and the protection of its intellectual property and confidential information; and YOUR WAIVER OF A RIGHT TO A JURY TRIAL AND AGREEMENT TO ARBITRATE ANY CLAIMS ON THE TERMS SET FORTH IN THE LICENSE.

©2020 Ushr Inc. All Rights Reserved. Please refer to www.ushrauto.com/copyright.

"Ushr", the Ushr logo, "Ushr Auto", and www.ushrauto.com are the intellectual property of Ushr Inc. and it reserves all rights in these marks.

©OpenStreetMap contributors, www.openstreetmap.org/copyright.

AUTOMATIC EMERGENCY BRAKING (AEB) WITH PEDESTRIAN DETECTION SYSTEM



WARNING

Failure to follow the warnings and instructions for proper use of the AEB with Pedestrian Detection system could result in serious injury or death.

- **The AEB with Pedestrian Detection system is a supplemental aid to the driver. It is not a replacement for the driver's attention to traffic conditions or responsibility to drive safely. It cannot prevent accidents due to carelessness or dangerous driving techniques.**
- **The AEB with Pedestrian Detection system does not function in all driving, traffic, weather and road conditions.**

The AEB with Pedestrian Detection system can assist the driver when there is a risk of a forward collision with

- a vehicle ahead in the travelling lane
- a pedestrian ahead in the travelling lane

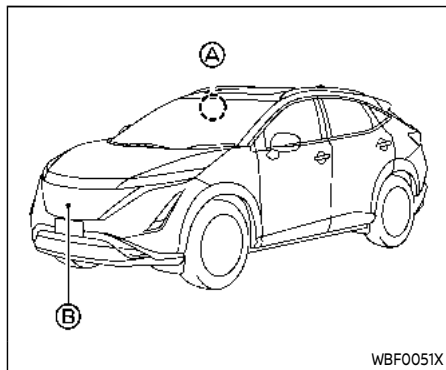

WBF0051X

The AEB with Pedestrian Detection system uses a radar sensor **B** located on the front of the vehicle to measure the distance to the vehicle ahead in the same lane.

For pedestrians, the AEB system uses a camera **A** installed behind the windshield in addition to the radar sensor.

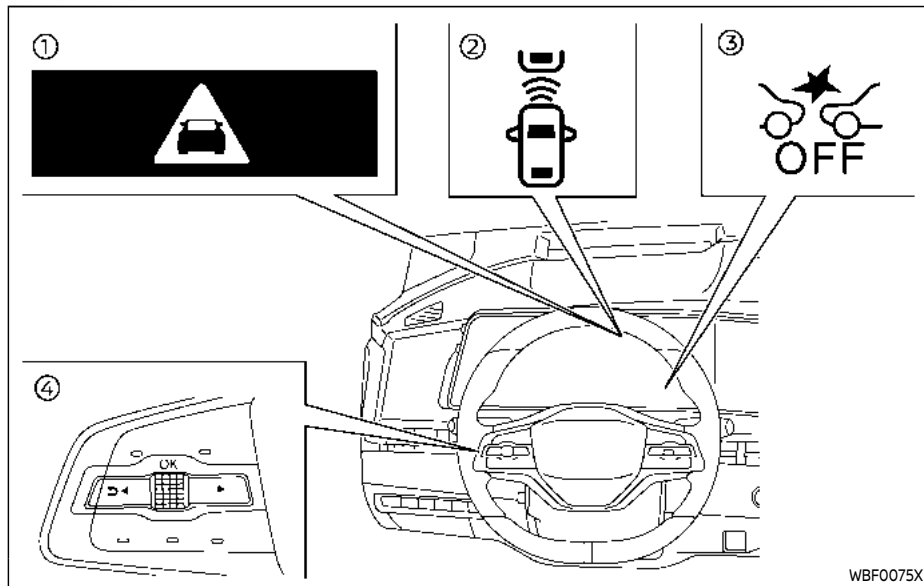

WBF0075X

- ① AEB emergency warning indicator
- ② Vehicle ahead detection indicator (on the vehicle information display)
- ③ AEB system OFF warning light (on the meter panel)
- ④ Steering-wheel-mounted controls (left side)

AEB WITH PEDESTRIAN DETECTION SYSTEM OPERATION

The AEB with Pedestrian Detection system will function when your vehicle is driven at speeds above approximately 3 MPH (5 km/h).

For the pedestrian detection function, the

AEB with Pedestrian Detection system operates at speeds between 6 – 37 MPH (10 – 60 km/h).

If a risk of a forward collision is detected, the AEB with Pedestrian Detection system will firstly provide the warning to the driver by flashing the vehicle ahead detection indicator (yellow) in the vehicle information display and providing an audible alert. In addition, the system applies partial braking.

If the driver applies the brakes quickly and forcefully after the warning, and the AEB with Pedestrian Detection system detects that there is still the possibility of a forward collision, the system will automatically increase the braking force.

If the driver does not take action, the AEB with Pedestrian Detection system issues the second visual (flashing red and white) and audible warning. Then the system applies partial braking.

If the risk of a collision becomes imminent, the AEB with Pedestrian Detection system applies harder braking automatically.

While the AEB with Pedestrian Detection system is operating, you may hear the sound of brake operation. This is normal and indicates that the AEB with Pedestrian Detection system is operating prop-

erly.

NOTE:

The vehicle's stop lights come on when braking is performed by the AEB with Pedestrian Detection system.

Depending on vehicle speed and distance to the vehicle, pedestrian ahead, as well as driving and roadway conditions, the system may help the driver avoid a forward collision or may help mitigate the consequences of a collision should one be unavoidable.

If the driver is handling the steering wheel, accelerating or braking, the AEB with Pedestrian Detection system will function later or will not function.

The automatic braking will cease under the following conditions:

- When the steering wheel is turned as far as necessary to avoid a collision.
- When the accelerator pedal is depressed.
- When there is no longer a vehicle, pedestrian detected ahead.

If the AEB with Pedestrian Detection system has stopped the vehicle, the vehicle will remain at a standstill for approximately 2 seconds before the brakes are released.

When the brake pedal is depressed while

the brake is applied by the system, you may feel the pedal effort is changed and may hear a sound and vibration noise. This is normal and does not indicate a malfunction. In addition, the braking force can be increased by adding the pedal effort.

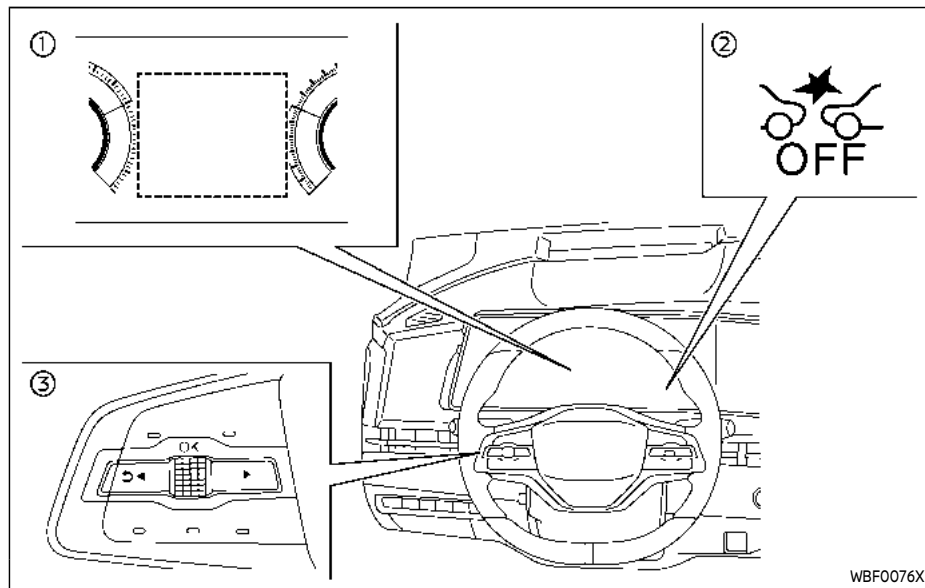

- ① AEB system OFF warning light (on the meter panel)
- ② Vehicle information display
- ③ Steering-wheel-mounted controls (left side)

TURNING THE AEB WITH PEDESTRIAN DETECTION SYSTEM ON/OFF

Perform the following steps to turn the AEB with Pedestrian Detection system on or off.

1. Push the ◀ ▶ button until "Settings" appears in the vehicle informa-

tion display and then push the scroll dial. Use the scroll dial to select "Driver Assistance." Then push the scroll dial.

2. Select "Emergency Assist" and push the scroll dial.
3. Select "Emergency Braking" and use the scroll dial to turn the system on or off.

When the AEB with Pedestrian Detection system is turned off, the AEB system OFF warning light illuminates.

NOTE:

- The AEB with Pedestrian Detection system will be automatically turned ON when the EV system is restarted.
- The Intelligent Forward Collision Warning (I-FCW) system is integrated into the AEB system. There is not a separate selection for the I-FCW system. When the AEB with Pedestrian Detection system is turned off, the I-FCW system is also turned off.

AEB WITH PEDESTRIAN DETECTION SYSTEM LIMITATIONS



WARNING

Listed below are the system limitations for the AEB with Pedestrian Detection system. Failure to operate the vehicle in accordance with these system limitations could result in serious injury or death.

- The AEB with Pedestrian Detection system cannot detect all vehicles, pedestrians under all conditions.
- The AEB with Pedestrian Detection system does not detect the following:
 - Pedestrians that are small (for example, children), in a sitting position, operating toys/skateboards, on scooters or in wheelchairs, or not in an upright standing or walking position.
 - Animals of any size.
 - Obstacles (for example, cargo or debris) on the roadway or roadside.

- Oncoming or crossing vehicles.

- Vehicles where the tires are difficult to see or the shape of the rear of the vehicle is unclear or obstructed.

- Parked vehicles.

- The AEB with Pedestrian Detection system has some performance limitations.

- If a stationary vehicle is in the vehicle's path, the system will not function when the vehicle approaches the stationary vehicle at speeds over approximately 50 MPH (80 km/h).

- Pedestrian detection will not function when the vehicle is driven at speeds over approximately 37 MPH (60 km/h) or below approximately 6 MPH (10 km/h).

- For pedestrians, the AEB with Pedestrian Detection system will not issue the first warning.
- The AEB with Pedestrian Detection system may not function properly or detect a vehicle or pedestrian ahead in the following conditions:

- In poor visibility conditions (such as rain, snow, fog, dust storms, sand storms, smoke, and road spray from other vehicles).

- If dirt, ice, snow, fog or other material is covering the radar sensor area or camera area of the windshield.

- If strong light (for example, sunlight or high beams) enters the front camera or a sudden change in brightness occurs (for example, entering a tunnel or driving in lighting).

- In dark or dimly lit conditions, such as at night or in tunnels, including cases where your vehicle's headlights are off or dim, or the tail lights of the vehicle ahead are off.

- When the direction of the camera is misaligned.

- When driving on a steep downhill slope, on roads with sharp curves, and/or bumpy or dirt roads.

- If there is interference by other radar sources.
- When your vehicle's position or movement is changed quickly or significantly (for example, lane change, turning vehicle, abrupt steering, sudden acceleration or deceleration).
- When your vehicle or the vehicle or pedestrian ahead moves quickly or significantly such that the system cannot detect and react in time (for example, pedestrian moving quickly toward the vehicle at close range, vehicle cutting in, changing lanes, making a turn, steering abruptly, sudden acceleration or deceleration).
- When the vehicle or pedestrian is offset from the vehicle's forward path.
- If the speed difference between the two vehicles is small.
- The pedestrian's profile is partially obscured or unidentifiable; for example, due to

- transporting luggage, pushing a stroller, wearing bulky or very loose-fitting clothing or accessories, or being in a unique posture (such as raising hands).
- There is poor contrast of a person to the background, such as having clothing color or pattern which is similar to the background.
- For approximately 15 seconds after starting the EV system
- If the vehicle ahead has a unique or unusual shape, extremely low or high clearance heights, or unusual cargo loading or is narrow (for example, a motorcycle).
- When the vehicle or pedestrian is located near a traffic sign, a reflective area (for example, water on road), or is in a shadow.
- When multiple pedestrians are grouped together.
- When the view of the pedestrian is obscured by a vehicle or other object.

- While towing a trailer or other vehicle (AWD models).
- The system performance may be degraded in the following conditions:
 - The vehicle is driven on a slippery road.
 - The vehicle is driven on a slope.
 - Excessively heavy baggage is loaded in the rear seat or the cargo area of your vehicle.
- The system is designed to automatically check the sensor (radar and camera)'s functionality, with certain limitations. The system may not detect some forms of obstruction of the sensor area such as ice, snow or stickers, for example. In these cases, the system may not be able to warn the driver properly. Be sure that you check, clean and clear sensor areas regularly.
- In some road and traffic conditions, the AEB with Pedestrian Detection system may unexpectedly apply partial braking. When acceleration is necessary, depress the accelerator pedal to

override the system.

- The AEB with Pedestrian Detection system may operate when a pattern, object, shadow or lights are detected that are similar to the outline of vehicles or pedestrians, or if they are the same size and position as a vehicle or motorcycle's tail lights.
- The system may keep operating when the vehicle ahead is turning right or left.
- The system may operate when your vehicle is approaching and passing a vehicle ahead.
- Depending on the road shape (curved road, entrance and exit of the curve, winding road, lane regulation, under construction, etc.), the system may operate temporarily for the oncoming vehicle in front of your vehicle.

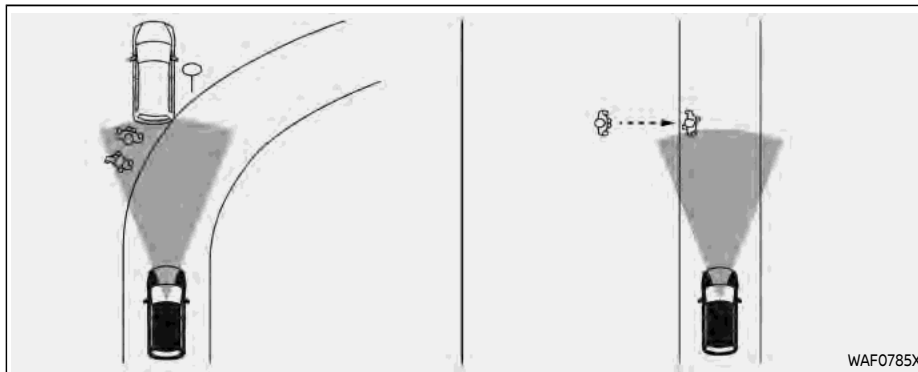

WARNING

Listed below are the system limitations for the AEB with Pedestrian Detection system. Failure to operate the vehicle in accordance with these system limitations could result in serious injury or death.

- The AEB with Pedestrian Detection system may react to:
 - objects on the roadside (traffic sign, guardrail, pedestrian, motorcycle, vehicle, etc.)

- pedestrians when driving on the narrow alleys, etc.
- pedestrians who temporarily protrude into or approaching the driving lane to avoid the obstacles on the road shoulder
- objects above road (low bridge, traffic sign, etc.)
- objects on the road surface (railroad track, grate, steel plate, etc.)
- objects in the parking garage (beam, pillar, etc.)

- pedestrians or motorcycles approaching the traveling lane
- vehicles, pedestrians, motorcycles or objects in adjacent lanes or close to the vehicle
- oncoming pedestrians
- objects on the road (such as trees)
- Braking distances increase on slippery surfaces.
- Excessive noise will interfere with the warning chime sound, and the chime may not be heard.

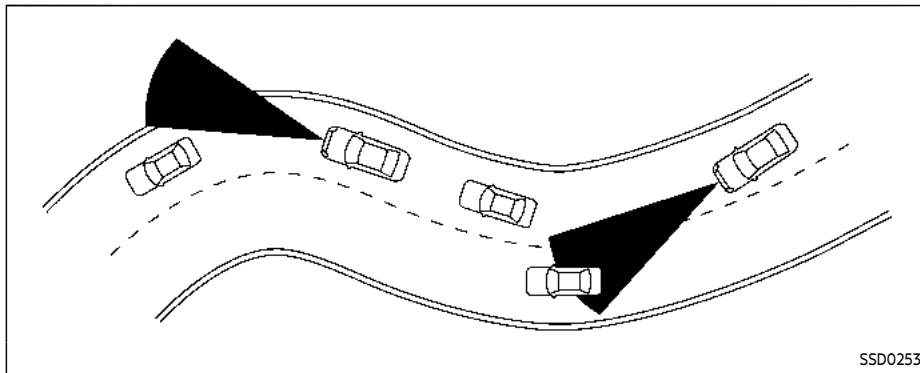

SSD0253

When driving on some roads, such as winding, hilly, curved, narrow roads, or roads which are under construction or on a slope, the sensor may detect vehicles in a different lane, or may temporarily not detect a vehicle traveling ahead. This may cause the system to work inappropriately.

The detection of vehicles may also be affected by vehicle operation (steering maneuver or traveling position in the lane, etc.) or vehicle condition. **If this occurs, the system may warn you by blinking the system indicator and sounding the chime unexpectedly. You will have to manually control the proper distance away from the vehicle traveling ahead.**

SYSTEM TEMPORARILY UNAVAILABLE

Condition A

If the following conditions, the AEB system OFF warning light will flash (no message appears in the vehicle information display).

- Strong light is shining from the front of the vehicle.
- The cabin temperature is over approximately 104°F (40°C) in direct sunlight.
- The camera area of the windshield is misted or frozen.

- The camera unit detects it's misalignment condition.
- The radar sensor picks up interference from another radar source.

Action to take:

When the above conditions no longer exist, the AEB with Pedestrian Detection system will resume automatically.

NOTE:

When the inside of the windshield on camera area is misted or frozen, it will take a period of time to remove it after air conditioner turns on. If dirt appears on this area, it is recommended you visit a NISSAN certified ARIYA dealer.

Condition B

In the following condition, the AEB system OFF warning light will flash and the "Forward Driving Aids temporarily disabled Front Sensor blocked See Owner's Manual" warning message will appear in the vehicle information display.

- The sensor area of the front of the vehicle is covered with dirt or is obstructed

Action to take:

If the warning light flashes, stop the vehicle in a safe place and turn the EV system off. Clean the radar cover on the front of the vehicle with a soft cloth, and

restart the EV system. If the warning message continues to appear, have the AEB with Pedestrian Detection system checked. It is recommended that you visit a NISSAN certified ARIYA dealer for this service.

- When driving on roads with limited road structures or buildings (for example, long bridges, deserts, snow fields, driving next to long walls).

Action to take:

When the above conditions no longer exist, the AEB with Pedestrian Detection system will resume automatically.

Condition C

When the Vehicle Dynamic Control (VDC) system is OFF, the AEB brake will not operate. In this case only visible and audible warning operates. The AEB system OFF warning light (orange) will illuminate.

Action to take:

When the VDC system is ON, the AEB with Pedestrian Detection system will resume automatically.

See "Driver assistance troubleshooting guide" (P.5-36).

SYSTEM MALFUNCTION

If the AEB with Pedestrian Detection system malfunctions, it will be turned off automatically, a chime will sound, the AEB system OFF warning light will (orange) will illuminate and the "Malfunction See Owner's Manual" warning message will appear in the vehicle information display.

Action to take:

If the warning light (orange) comes on, stop the vehicle in a safe location. Turn the EV system off and restart the EV system. If the warning light continues to illuminate, have the AEB with Pedestrian Detection system checked. It is recommended that you visit a NISSAN certified ARIYA dealer for this service.

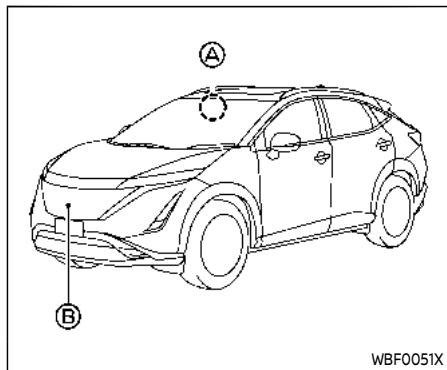

SYSTEM MAINTENANCE

The radar sensor ② is located on the front of the vehicle. The camera ① is located on the upper side of the windshield.

To keep the AEB with Pedestrian Detection system operating properly, be sure to observe the following:

- Always keep the sensor area on the front of the vehicle and windshield clean.
- Do not strike or damage the areas around the sensors (ex. bumper, windshield).
- Do not cover or attach stickers or similar objects on the front of the vehicle near the sensor area. This

could cause failure or malfunction.

- Do not attach metallic objects near the radar sensor area (brush guard, etc.). This could cause failure or malfunction.
- Do not place reflective materials, such as white paper or a mirror, on the instrument panel. The reflection of sunlight may adversely affect the camera unit's detection capability.
- Do not alter, remove or paint the front of the vehicle near the sensor area. Before customizing or restoring the sensor area, it is recommended that you visit a NISSAN certified ARIYA dealer.

Radio frequency statement

For USA

Type approval number:

FCC ID: NF3-FR5CPEC

User Manual statement according to §15.19:

This device complies with Part 15 of the FCC Rules.

Operation is subject to the following two conditions:

1. this device may not cause harmful interference, and

2. this device must accept any interference received, including interference that may cause undesired operation.

User Manual statement according to §15.21:

Changes or modifications made to this equipment not expressly approved by Robert BOSCH GmbH may void the FCC authorization to operate this equipment.

User Manual statement according to §15.105:

This equipment has been tested and found to comply with the limits for a Class A digital device, pursuant to Part 15 of the FCC Rules. These limits are designed to provide reasonable protection against harmful interference when the equipment is operated in a commercial environment. This equipment generates, uses, and can radiate radio frequency energy and, if not installed and used in accordance with the instruction manual, may cause harmful interference to radio communications. Operation of this equipment in a residential area is likely to cause harmful interference in which case the user will be required to correct the interference at his own expense.

RF Exposure Information according 2.1091/2.1093/OET bulletin 65:

Radiofrequency radiation exposure infor-

INTELLIGENT FORWARD COLLISION WARNING (I-FCW)

mation:

This equipment complies with FCC radiation exposure limits set forth for an uncontrolled environment. This equipment should be installed and operated with minimum distance of 20 cm between the radiator and your body.

The transmitter must not be co-located or operating in conjunction with any other antenna or transmitter.

For Canada

Type approval number:

IC: 3387A-FR5CPEC

Legal warning for RF equipment:

This device complies with Industry Canada licence-exempt RSS standard(s). Operation is subject to the following two conditions: (1) this device may not cause interference, and (2) this device must accept any interference, including interference that may cause undesired operation of the device.



WARNING

Failure to follow the warnings and instructions for proper use of the I-FCW system could result in serious injury or death.

- **The I-FCW system helps warn the driver before a collision but will not avoid a collision. It is the driver's responsibility to stay alert, drive safely and be in control of the vehicle at all times.**

The I-FCW system can help alert the driver when there is a sudden braking of a second vehicle traveling in front of the vehicle ahead in the same lane.

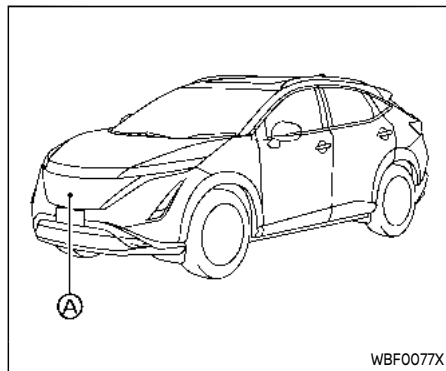

The I-FCW system uses a radar sensor (A) located on the front of the vehicle to measure the distance to a second vehicle ahead in the same lane.

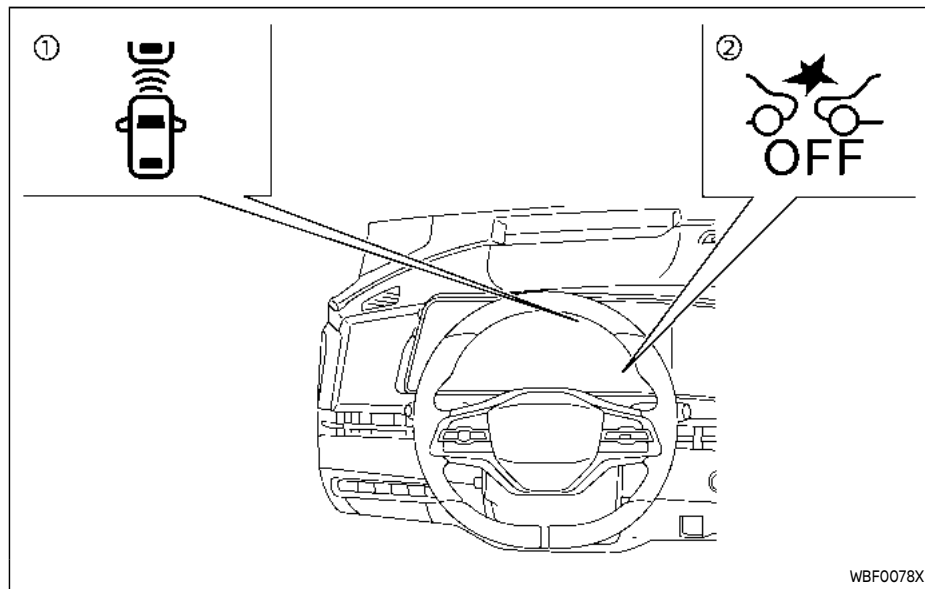

WBF0078X

- ① Vehicle ahead detection indicator (on the vehicle information display)
- ② Automatic Emergency Braking (AEB) system OFF warning light (on the meter panel)

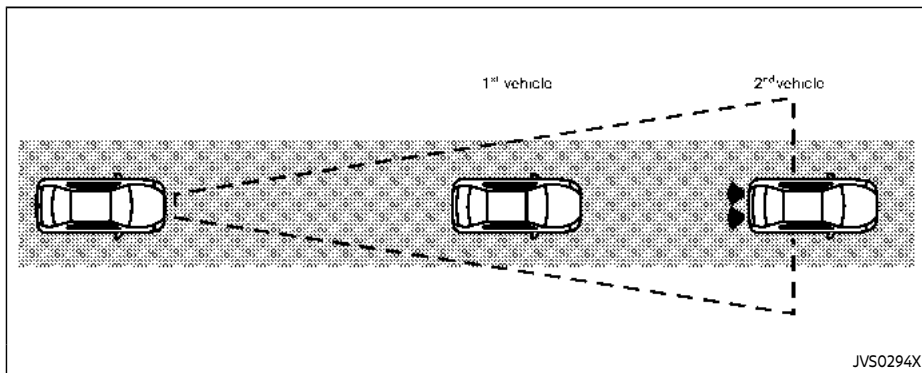

I-FCW SYSTEM OPERATION

The I-FCW system operates at speeds above approximately 3 MPH (5 km/h).

If there is a potential risk of a forward collision, the I-FCW system will warn the driver by blinking the vehicle ahead detection indicator, and sounding an audible alert.

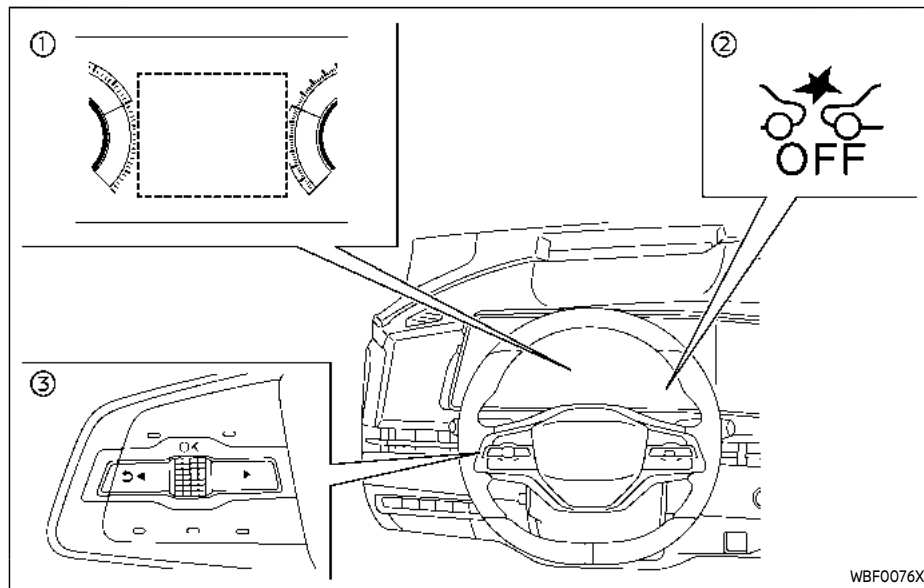

- ① AEB system OFF warning light (on the meter panel)
- ② Vehicle information display
- ③ Steering-wheel-mounted controls (left side)

TURNING THE I-FCW SYSTEM ON/ OFF

Perform the following steps to turn the I-FCW system on or off.

1. Push the ◀ ▶ button until "Settings" appears in the vehicle information display and then push the scroll

dial. Use the scroll dial to select "Driver Assistance." Then push the scroll dial.

2. Select "Emergency Assist" and push the scroll dial.
3. Select "Emergency Braking" and use the scroll dial to turn the system on or off.

When the I-FCW system is turned off, the AEB system OFF warning light (orange) illuminates.

NOTE:

- The I-FCW system will be automatically turned on when the EV system is restarted.
- The I-FCW system is integrated into the AEB system. There is not a separate selection for the I-FCW system. When the AEB system is turned off, the I-FCW system is also turned off.

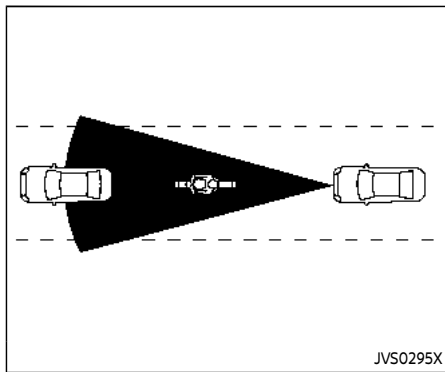

Illustration A

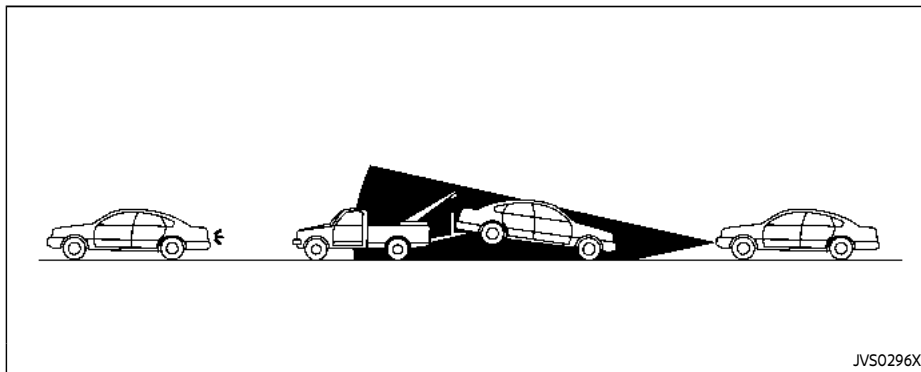

Illustration B

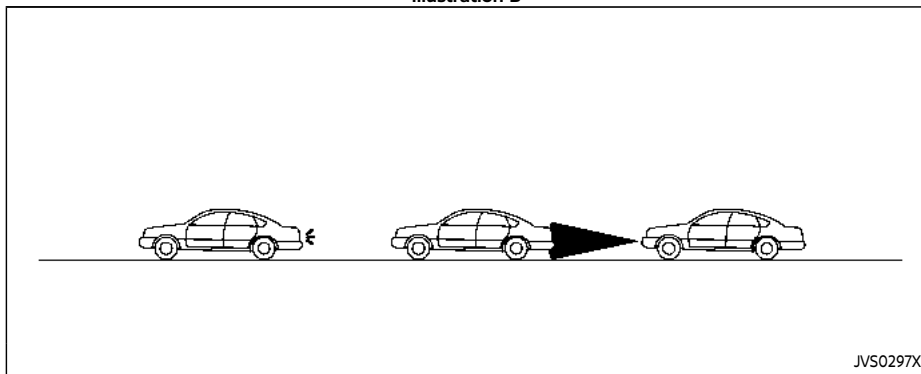
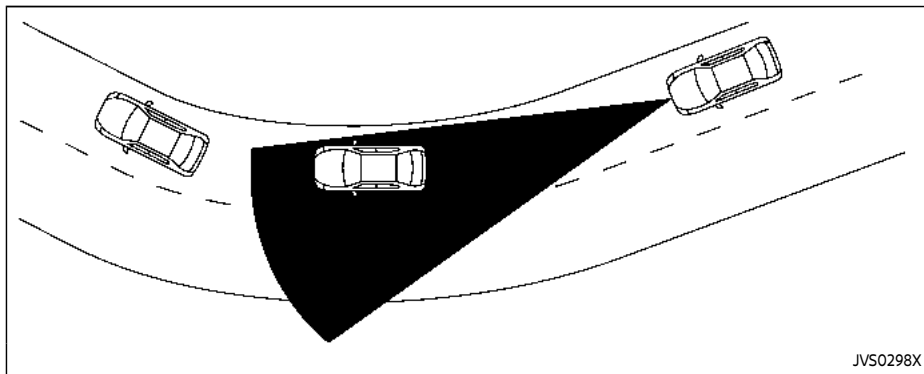

Illustration C



JVS0298X

Illustration D

I-FCW SYSTEM LIMITATIONS



WARNING

Listed below are the system limitations for the I-FCW system. Failure to operate the vehicle in accordance with these system limitations could result in serious injury or death.

- The I-FCW system cannot detect all vehicles under all conditions.
- The radar sensor does not detect the following objects:

- Pedestrians, animals or obstacles in the roadway
- Oncoming vehicles
- Crossing vehicles

- (Illustration A) The I-FCW system does not function when a vehicle ahead is a narrow vehicle, such as a motorcycle.
- The radar sensor may not detect a vehicle ahead in the following conditions:
 - Snow or heavy rain

- Dirt, ice, snow or other material covering the radar sensor
- Interference by other radar sources
- Snow or road spray from travelling vehicles.
- Driving in a tunnel
- Towing a trailer (AWD models)
- (Illustration B) When the vehicle ahead is being towed.
- (Illustration C) When the distance to the vehicle ahead is too close, the beam of the radar sensor is obstructed.
- (Illustration D) When driving on a steep downhill slope or roads with sharp curves.
- The system is designed to automatically check the sensor's functionality, within certain limitations. The system may not detect some forms of obstruction of the sensor area such as ice, snow, stickers, for example. In these cases, the system may not be able to warn the driver properly. Be sure that you check, clean and clear the sensor area regularly.

- Excessive noise will interfere with the warning chime sound, and the chime may not be heard.

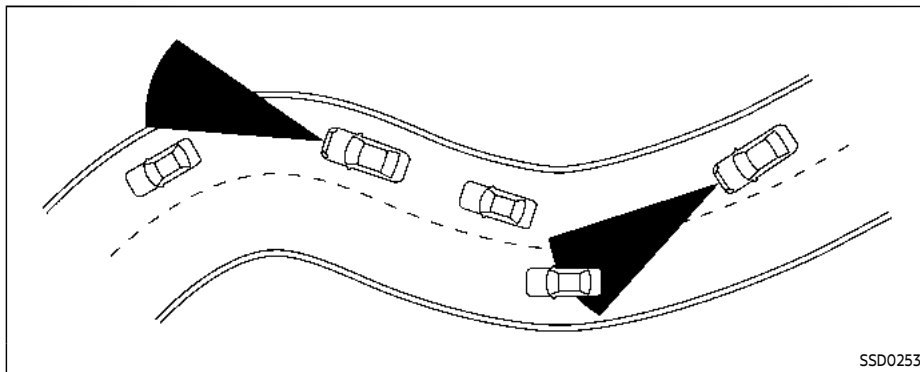

When driving on some roads, such as winding, hilly, curved, narrow roads, or roads which are under construction, the radar sensor may detect vehicles in a different lane, or may temporarily not detect a vehicle traveling ahead. This may cause the I-FCW system to work inappropriately.

The detection of vehicles may also be affected by vehicle operation (steering maneuver or traveling position in the lane, etc.) or vehicle condition. **If this occurs, the system may warn you by blinking the vehicle ahead detection indicator and sounding the chime unexpectedly. You will have to manually control the proper distance away from**

the vehicle traveling ahead.

SYSTEM TEMPORARILY UNAVAILABLE

Condition A

When the radar sensor picks up interference from another radar source, making it impossible to detect a vehicle ahead, the I-FCW system is automatically turned off. The AEB system OFF warning light (orange) will flash.

Action to take:

When the above conditions no longer exist, the I-FCW system will resume automatically.

Condition B

Under the following conditions, making it impossible to detect a vehicle ahead, the I-FCW system is automatically turned off.

The AEB system OFF warning light (orange) will flash and the "Forward Driving Aids temporarily disabled Front Sensor blocked See Owner's Manual" warning message will appear in the vehicle information display.

- When the sensor area of the front of the vehicle is covered with dirt or is obstructed

Action to take:

If the warning light (orange) flashes, stop the vehicle in a safe place, push the park button to engage the P (Park) position and turn the EV system off. Clean the radar cover on the front of the vehicle with a soft cloth, and restart the EV system. If the warning light continues to illuminate, have the I-FCW system checked. It is recommended you visit a NISSAN certified ARIYA dealer for this service.

- When driving on roads with limited road structures or buildings (for example, long bridges, deserts, snow fields, driving next to long walls)

Action to take:

When the above conditions no longer

exist, the I-FCW system will resume automatically.

See "Driver assistance troubleshooting guide" (P.5-36).

SYSTEM MALFUNCTION

If the I-FCW system malfunctions, it will be turned off automatically, a chime will sound, the AEB system OFF warning light (orange) will illuminate and the "Malfunction See Owner's Manual" warning message will appear in the vehicle information display.

Action to take:

If the warning light (orange) illuminates, stop the vehicle in a safe location. Turn the EV system off and restart the EV system. If the warning light continues to illuminate, have the I-FCW system checked. It is recommended you visit a NISSAN certified ARIYA dealer for this service.

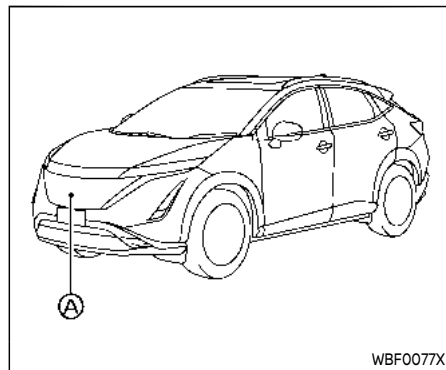

SYSTEM MAINTENANCE

The radar sensor (A) is located on the front of the vehicle.

To keep the system operating properly, be sure to observe the following:

- Always keep the sensor area on the front of the vehicle clean.
- Do not strike or damage the areas around the sensor.
- Do not cover or attach stickers or similar objects on the front bumper near the sensor area. This could cause failure or malfunction.
- Do not attach metallic objects near the sensor area (brush guard, etc.). This could cause failure or malfunction.

tion.

- Do not alter, remove or paint the front bumper. It is recommended you contact a NISSAN certified ARIYA dealer before customizing or restoring the front bumper.

Radio frequency statement

For USA

Type approval number:

FCC ID: NF3-FR5CPEC

User Manual statement according to §15.19:

This device complies with Part 15 of the FCC Rules.

Operation is subject to the following two conditions:

1. this device may not cause harmful interference, and
2. this device must accept any interference received, including interference that may cause undesired operation.

User Manual statement according to §15.21:

Changes or modifications made to this equipment not expressly approved by Robert BOSCH GmbH may void the FCC authorization to operate this equipment.

User Manual statement according to §15.105:

5-138 **Starting and driving**

This equipment has been tested and found to comply with the limits for a Class A digital device, pursuant to Part 15 of the FCC Rules. These limits are designed to provide reasonable protection against harmful interference when the equipment is operated in a commercial environment. This equipment generates, uses, and can radiate radio frequency energy and, if not installed and used in accordance with the instruction manual, may cause harmful interference to radio communications. Operation of this equipment in a residential area is likely to cause harmful interference in which case the user will be required to correct the interference at his own expense.

RF Exposure Information according 2.1091/2.1093/OET bulletin 65:

Radiofrequency radiation exposure information:

This equipment complies with FCC radiation exposure limits set forth for an uncontrolled environment. This equipment should be installed and operated with minimum distance of 20 cm between the radiator and your body.

The transmitter must not be co-located or operating in conjunction with any other antenna or transmitter.

For Canada

Type approval number:

IC: 3387A-FR5CPEC

Legal warning for RF equipment:

This device complies with Industry Canada licence-exempt RSS standard(s). Operation is subject to the following two conditions: (1) this device may not cause interference, and (2) this device must accept any interference, including interference that may cause undesired operation of the device.

INTELLIGENT DRIVER ALERTNESS (I-DA)



WARNING

Failure to follow the warnings and instructions for proper use of the I-DA system could result in serious injury or death.

- The I-DA system is only a warning to inform the driver of a potential lack of driver attention or drowsiness. It will not steer the vehicle or prevent loss of control.
- The I-DA system does not detect and provide an alert of the driver's lack of attention or fatigue in every situation.
- It is the driver's responsibility to:
 - Stay alert.
 - Drive safely.
 - Keep the vehicle in the traveling lane.
 - Be in control of the vehicle at all times.
 - Avoid driving when tired.
 - Avoid distractions (texting, etc).

The I-DA system helps alert the driver if the system detects a lack of attention or driving fatigue.

The system monitors driving style and steering behavior over a period of time, and it detects changes from the normal pattern. If the system detects that driver attention is decreasing over a period of time, the system uses audible and visual warnings to suggest that the driver take a break.

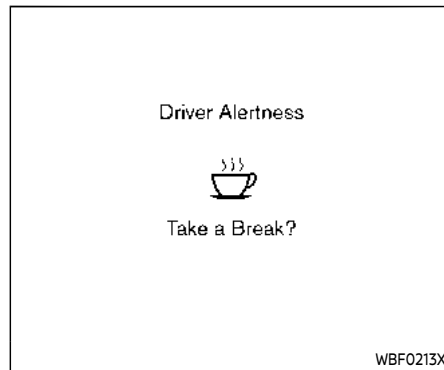

Example

I-DA SYSTEM OPERATION

If the system detects driver fatigue or that driver attention is decreasing, the message "Take a Break?" appears in the vehicle information display and a chime sounds when the vehicle is driven at speeds above 37 MPH (60 km/h).

The system continuously monitors driver attention and can provide multiple warnings per trip.

The system resets and starts reassessing driving style and steering behavior when the power switch is cycled from the ON to the OFF position and back to the ON position.

The system will not operate when Steering Assist system is activated.

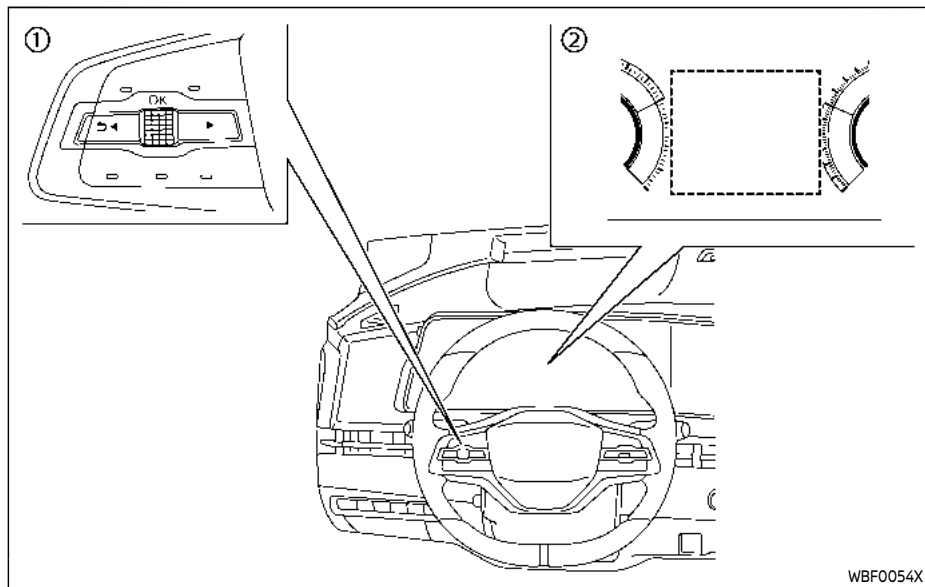

- ① Steering-wheel-mounted control (left side)
- ② Vehicle information display

HOW TO ENABLE/DISABLE THE I-DA SYSTEM

Perform the following steps to enable or disable the I-DA system.

1. Push the ◀ ▶ button until "Settings" appears in the vehicle information display and push the scroll dial.

REAR AUTOMATIC BRAKING (RAB)

- Use the scroll dial to select "Driver Assistance." Then push the scroll dial.
2. Select "Driver Monitor" and push the scroll dial.
 3. Select "Driver Alertness" and use the scroll dial to turn the system on or off.

NOTE:

The I-DA system will automatically be turned on when the EV system is restarted.

I-DA SYSTEM LIMITATIONS



WARNING

Listed below are the system limitations for the I-DA system. Failure to operate the vehicle in accordance with these system limitations could result in serious injury or death.

- The I-DA system may not operate properly and may not provide an alert in the following conditions:
 - Poor road conditions such as an uneven road surface or pot holes.
 - Strong side wind.
 - If you have adopted a sporty driving style with higher cornering speeds or higher rates

of acceleration.

- Frequent lane changes or changes to vehicle speed.
- The I-DA system will not provide an alert in the following conditions:
 - Vehicle speeds lower than 37 MPH (60 km/h).
 - Short lapses of attention.
 - Instantaneous distractions such as dropping an object.

SYSTEM MALFUNCTION

If the I-DA system malfunctions, the "Malfunction See Owner's Manual" warning message will appear in the vehicle information display and the function will be stopped automatically.

Action to take

Stop the vehicle in a safe location, place the vehicle in P (Park) position, turn the EV system off and restart the EV system. If the warning message continues to appear, have the system checked. It is recommended that you visit a NISSAN certified ARIYA dealer for this service.



WARNING

Failure to follow the warnings and instructions for proper use of the RAB system could result in serious injury or death.

- The RAB system is a supplemental aid to the driver. It is not a replacement for proper driving procedures. Always use the side and rear mirrors and turn and look in the direction you will move before and while backing up. Never rely solely on the RAB system. It is the driver's responsibility to stay alert, drive safely, and be in control of the vehicle at all times.
- There is a limitation to the RAB system capability. The RAB system is not effective in all situations.

The RAB system can assist the driver when backing up and approaching an object directly behind the vehicle. If an item is detected, and the driver fails to stop, this feature can automatically engage the brakes to help avoid a rear collision or help lessen the severity of an impact.

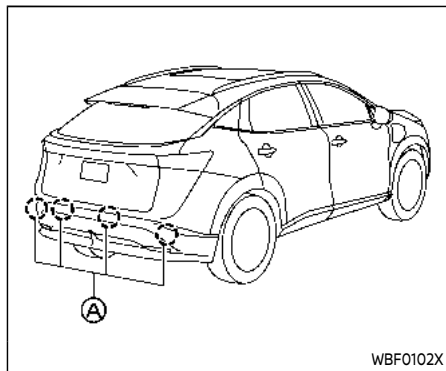

Models with 4 sonar sensors

The RAB system detects obstacles behind the vehicle using the sonar sensors **A** located on the rear bumper.

NOTE:

You can temporarily cancel the sonar function and the RAB system in the vehicle. For additional information, see "Sonar system" (P.5-160).

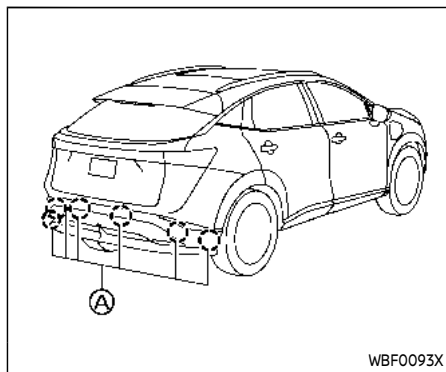

Models with 6 sonar sensors

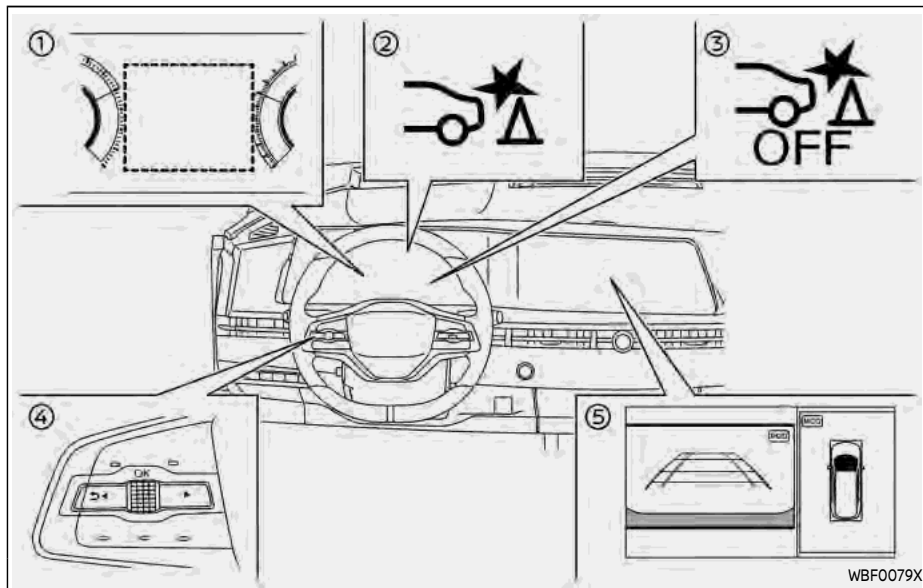

- ① Vehicle information display
- ② RAB system warning indicator (on the vehicle information display)
- ③ RAB system OFF warning light (on the meter panel)
- ④ Steering-wheel-mounted controls (left side)
- ⑤ Center display (if so equipped)

RAB SYSTEM OPERATION

When the shift lever is in the R (Reverse) position and the vehicle speed is less than approximately 9 MPH (15 km/h), the RAB system operates.

If a risk of a collision with an obstacle is detected when your vehicle is backing up, the RAB system warning indicator will flash in the vehicle information display, a red frame will appear in the center display (models with the Intelligent Around View® Monitor system), and the system will chime three times. The system will then automatically apply the brakes. After the automatic brake application, the driver must depress the brake pedal to maintain brake pressure.

NOTE:

- **The stop lights of the vehicle come on when braking is performed by the RAB system.**
- **When the brakes operate, a noise may be heard. This is not a malfunction.**

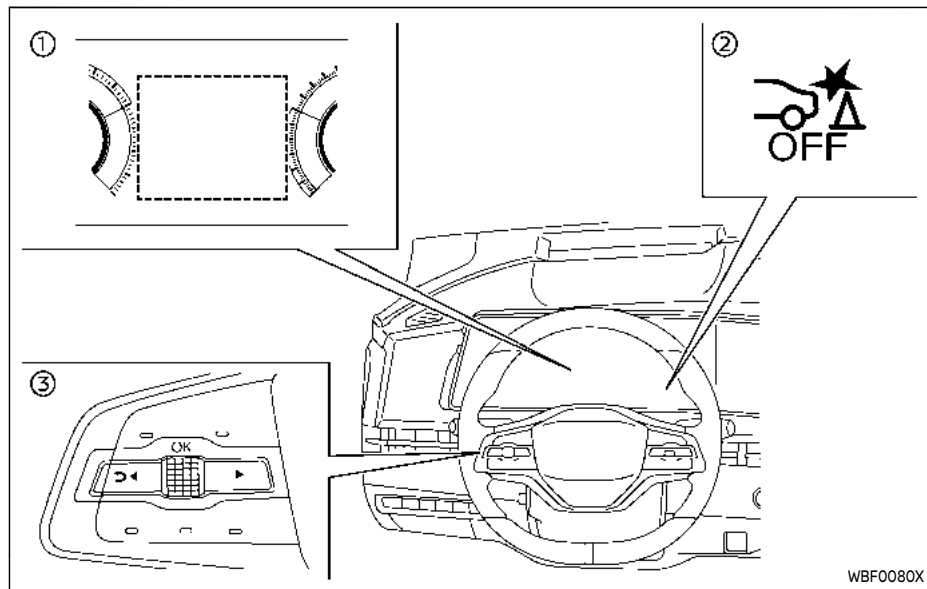

- ① Vehicle information display
- ② RAB system OFF warning light
- ③ Steering-wheel-mounted control (left side)

HOW TO ENABLE/DISABLE REAR AUTOMATIC BRAKING

Perform the following steps to turn the RAB system ON or OFF.

1. Push the ◀ ▶ button until "Settings" appears in the vehicle information display and then push the scroll

dial. Use the scroll dial to select "Driver Assistance." Then push the scroll dial.

2. Select "Emergency Assist" and push the scroll dial.
3. Select "Rear Auto Braking" and use the scroll dial to turn the system on or off.

When the RAB system is turned off, the RAB system OFF warning light illuminates when the shift lever is in the R (Reverse) position.

The RAB system OFF warning light will also illuminate when the shift lever is in the R (Reverse) position and the RAB system is ON if the sonar sensors have been temporarily disabled using the "Parking Assist" setting.

NOTE:

- The RAB system will be automatically turned on when the EV system is restarted.
- When the shift lever is in the R (Reverse) position and the Parking Assist screen is displayed in the vehicle information display the RAB system can be disabled temporarily by pushing the scroll dial on the steering wheel.

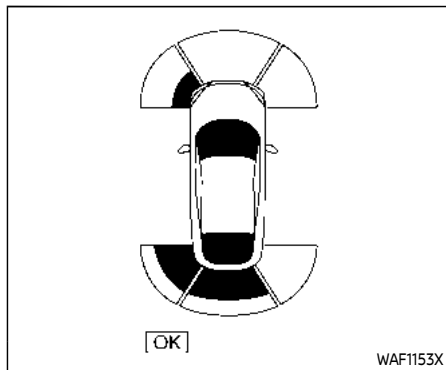

RAB SYSTEM LIMITATIONS

WARNING

Listed below are the system limitations for the RAB system. Failure to follow the warnings and instructions for proper use of the RAB system could result in serious injury or death.

- When the vehicle approaches an obstacle while the accelerator or brake pedal is depressed, the function may not operate or the start of the operation may be

delayed. The RAB system may not operate or may not perform sufficiently due to vehicle conditions, driving conditions, the traffic environment, the weather, road surface conditions, etc. Do not wait for the system to operate. Operate the brake pedal by yourself as soon as necessary.

- If it is necessary to override RAB operation, strongly press the accelerator pedal.
- Always check your surroundings and turn to check what is behind you before and while backing up. The RAB system detects stationary objects behind the vehicle. The RAB system does not detect the following objects:
 - Moving objects
 - Low objects
 - Narrow objects
 - Wedge-shaped objects
 - Complex-shaped objects
 - Multiple object in close
 - Objects close to the bumper (less than approximately 1 ft [30 cm])

- Objects that suddenly appear
- Thin objects such as rope, wire, chain, etc.
- The RAB system may not operate for pedestrians or animals.
- The RAB system may not operate for the following obstacles:
 - Obstacles located high off the ground
 - Obstacles in a position offset from your vehicle
 - Obstacles, such as spongy materials or snow, that have soft outer surfaces and can easily absorb a sound wave
- The RAB system may not operate in the following conditions:
 - There is rain, snow, ice, dirt, etc., attached to the sonar sensors.
 - A loud sound is heard in the area around the vehicle.
 - The surface of the obstacle is diagonal to the rear of the vehicle.
 - The sonar sensors or the area around them are extremely hot or cold.

- The RAB system may unintentionally operate in the following conditions:
 - There is overgrown grass in the area around the vehicle.
 - There is a structure (e.g., a wall, toll gate equipment, a narrow tunnel, a parking lot gate) near the side of the vehicle.
 - There are bumps, protrusions, or manhole covers on the road surface.
 - The vehicle is driving through a draped flag or a curtain.
 - The vehicle is driving on a steep hill.
 - There is an accumulation of snow or ice behind the vehicle.
 - An ultrasonic wave source, such as another vehicle's sonar, is near the vehicle.
- Once the automatic brake control operates, it does not operate again if the vehicle approaches the same obstacle.

- The automatic brake control can only operate for a short period of time. Therefore, the driver must depress the brake pedal.
- In the following situations, the RAB system may not operate properly or may not function sufficiently:
 - The vehicle is driven in bad weather (rain, fog, snow, etc.).
 - The vehicle is driven on a steep hill.
 - The vehicle's posture is changed (e.g., when driving over a bump).
 - The vehicle is driven on a slippery road.
 - The vehicle is turned sharply by turning the steering wheel fully.
 - Snow chains are used.
 - Wheels or tires other than NISSAN recommended are used.
 - The brakes are cold at low ambient temperatures or immediately after driving has started.

- The braking force becomes poor due to wet brakes after driving through a puddle or washing the vehicle.
- Turn the RAB system off in the following conditions to prevent the occurrence of an unexpected activation resulting from sudden system operation:
 - The vehicle is towed.
 - The vehicle is carried on a flatbed truck.
 - The vehicle is on the chassis dynamometer.
 - The vehicle drives on an uneven road surface.
 - The vehicle is towing an object (if so equipped).
 - Suspension parts other than those designated as genuine parts are used. (If the vehicle height or the vehicle body inclination is changed, the system may not detect an obstacle correctly.)
 - If the vehicle is using an accessory like a bike rack or cargo carrier that blocks the sensors.

- **Excessive noise (e.g., audio system volume, an open vehicle window) will interfere with the chime sound, and it may not be heard.**

See "Driver assistance troubleshooting guide" (P.5-36).

SYSTEM MALFUNCTION

If the RAB system malfunctions, it will be turned off automatically, the RAB system OFF warning light will illuminate, and the "Malfunction See Owner's Manual" warning message will appear in the vehicle information display.

Action to take

If the warning light illuminates, park the vehicle in a safe location, turn the EV system off, and restart the EV system. If the warning light continues to illuminate, have the RAB system checked. It is recommended that you visit a NISSAN certified ARIYA dealer for this service.

NOTE:

If the RAB system cannot be operated temporarily, the RAB system OFF warning light blinks.

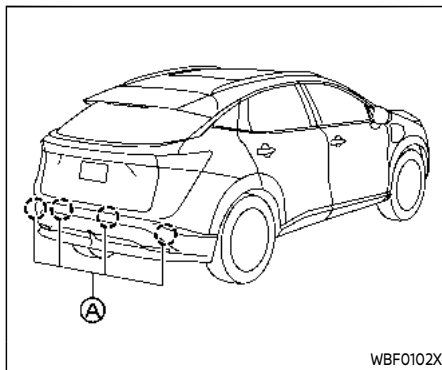

Models with 4 sonar sensors

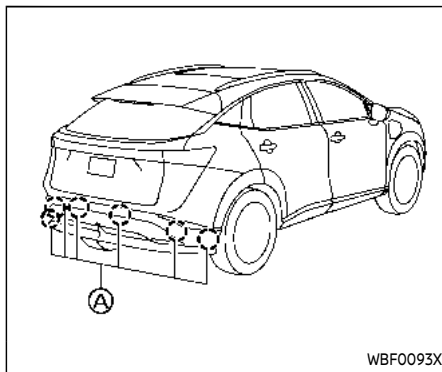

Models with 6 sonar sensors

SYSTEM MAINTENANCE

The sonar sensors (A) are located on the rear bumper. Observe the following items to ensure proper operation of the system:

- Always keep the sonar sensors clean.
- If the sonar sensors are dirty, wipe them off with a soft cloth while being careful to not damage them.
- The sonar sensors may be blocked by temporary ambient conditions such as splashing water, mist or fog. The blocked condition may also be caused by objects such as ice, frost or dirt obstructing the sonar sensors. Check for and remove objects obstructing the area around the sonar sensors.
- Do not subject the area around the sonar sensors to strong impact. Also, do not remove or disassemble the sonar sensors. If the sonar sensors and peripheral areas are deformed in an accident, etc., have the sonar sensors checked. It is recommended that you visit a NISSAN certified ARIYA dealer for this service.
- Do not attach stickers (including transparent material), install accessories or apply additional paint on the sonar sensors and their surrounding areas. This may cause a malfunction or improper operation.

INCREASING POWER ECONOMY

- When washing the vehicle using a high-pressure washer, do not apply direct washer pressure on the sonar sensors. This may cause a malfunction of the sonar sensors.

The actual driving range will vary depend upon:

- speed
- vehicle load
- electrical load from vehicle accessories
- traffic and road conditions

NISSAN recommends the following driving habits to help maximize driving range:

Before driving:

- Follow recommended scheduled maintenance.
- Keep tires inflated to the correct pressure.
- Keep wheels in correct alignment.
- Pre-heat or pre-cool the interior cabin while the vehicle is charging.
- Remove unnecessary cargo from the vehicle.

While driving:

- Drive in ECO mode
 - The ECO mode helps reduce power consumption by reducing acceleration when compared to the same accelerator pedal position in the STANDARD mode.
- Drive at a constant speed. Maintain cruising speeds with constant accelerator pedal positions or use the

cruise control system when appropriate.

- Accelerate slowly and smoothly. Gently depress and release the accelerator pedal for acceleration and deceleration.
- Drive at moderate speeds on the highway.
- Avoid frequent stopping and braking. Maintain a safe distance behind other vehicles.
- Turn off the climate control system when it is not necessary.
- Select a moderate temperature setting for heating or cooling to help reduce power consumption.
- Use the “Fan ONLY” to help reduce power consumption.
- In cold weather, use the heated seats and the heated steering wheel (if so equipped) as a substitute for the climate control system to help reduce power consumption.
- Use the climate control system and close windows to reduce drag when cruising at highway speed.
- Release the accelerator pedal to slow down and do not apply the brakes when traffic and road conditions allow.

- This vehicle is equipped with a regenerative brake system. The primary purpose of regenerative brake system is to provide some power to recharge the Li-ion battery and extend driving range. A secondary benefit is “engine braking” that operates based on Li-ion battery conditions. In the D (Drive) or B position, when the accelerator pedal is released, the regenerative brake system provides some deceleration and some power to the Li-ion battery.

ALL-WHEEL DRIVE (AWD) SYSTEM (if so equipped)



WARNING

- **For AWD equipped vehicles, do not attempt to raise two wheels off the ground and shift the transmission to any drive or reverse position with the EV system running. Doing so may result in drivetrain damage or unexpected vehicle movement which could result in serious vehicle damage or personal injury.**
- **Do not attempt to test an AWD equipped vehicle on a 2-wheel dynamometer or similar equipment even if the other two wheels are raised off the ground. Make sure that you inform the test facility personnel that your vehicle is equipped with AWD before it is placed on a dynamometer. Using the wrong test equipment may result in drivetrain damage or unexpected vehicle movement which could result in serious vehicle damage or personal injury.**



CAUTION

Do not operate the EV system on a free roller when any of the wheels raised.

When the vehicle is in the P (Park) position, the operation noise may be heard from the lower part of the vehicle. This is not a malfunction.

PARKING/PARKING ON HILLS

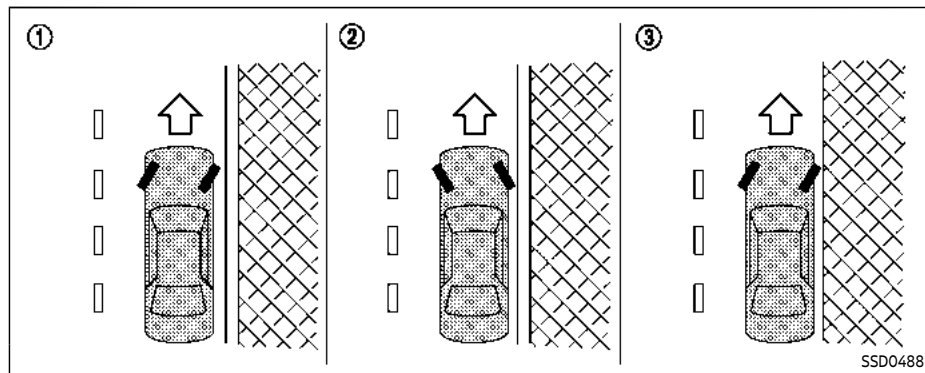

WARNING

- Do not stop or park the vehicle over flammable materials such as dry grass, waste paper or rags. They may ignite and cause a fire.
- Never leave the vehicle in the READY to drive mode while the vehicle is unattended.
- Do not leave children unattended inside the vehicle. They could unknowingly activate switches or controls. Unattended children could become involved in serious

accidents.

- To help avoid risk of injury or death through unintended operation of the vehicle and/or its systems, do not leave children, people who require the assistance of others or pets unattended in your vehicle. Additionally, the temperature inside a closed vehicle on a warm day can quickly become high enough to cause a significant risk of injury or death to people and pets.

- Safe parking procedures require that both the parking brake be applied and the transmission placed into P (Park). Failure to do so could cause the vehicle to move unexpectedly or roll away and result in an accident.
- Make sure the shift lever cannot be moved without depressing the foot brake pedal.

1. Apply the parking brake.
2. Push the park button to shift to the P (Park) position.
3. To help prevent the vehicle from rolling into the street when parked on a sloping drive way, it is a good practice to turn the wheels as illustrated.
 - HEADED DOWNHILL WITH CURB: ①
Turn the wheels into the curb and move the vehicle forward until the curb side wheel gently touches the curb.
 - HEADED UPHILL WITH CURB: ②
Turn the wheels away from the curb and move the vehicle back until the curb side wheel gently touches the curb.
 - HEADED UPHILL OR DOWNHILL, NO CURB: ③
Turn the wheels toward the side of

ELECTRIC POWER STEERING

the road so the vehicle will move away from the center of the road if it moves.

4. Place the power switch in the OFF position.



WARNING

- **If the READY to drive indicator light is OFF while driving, the power assist for the steering will not work. Steering will be harder to operate.**
- **When the electric power steering warning light illuminates while the READY to drive indicator light is ON, the power assist for the steering will be limited or cease operation. You will still have control of the vehicle but the steering will be harder to operate.**

The electric power steering is designed to provide power assist while driving to operate the steering wheel with light force.

When SPORT mode is selected, the steering wheel effort is moderately increased for a sporty feel. (See "SPORT mode" (P.5-31).)

When the steering wheel is operated repeatedly or continuously while parking or driving at a very low speed, the power assist for the steering wheel will be reduced. This is to prevent overheating of the electric power steering and protect

it from getting damaged. While the power assist is reduced, steering wheel operation will become heavy. If the steering wheel operation is still performed, the electric power steering may stop and the electric power steering warning light  will illuminate. In a safe location, stop the EV system and place the power switch in the OFF position. When the temperature of the electric power steering goes down, the power assist level will return to normal. Avoid repeating such steering wheel operations that could cause the electric power steering to overheat.

You may hear a noise when the steering wheel is operated quickly. However, this is not a malfunction.

If the electric power steering warning light illuminates while the READY to drive indicator light is ON, it may indicate the electric power steering is not functioning properly and may need servicing. Have the electric power steering checked. It is recommended that you visit a NISSAN certified ARIYA dealer for this service. (See "Electric power steering warning light" (P.2-17).)

When the electric power steering warning light illuminates, the power assist for the steering will be limited or cease operation, which may cause the steering wheel operation to become heavy. Even if this

BRAKE SYSTEM

occurs, the performance of the manual steering is ensured. Grip the steering wheel securely and operate it with greater force than usual.

BRAKING PRECAUTIONS

This vehicle is equipped with two braking systems:

1. Hydraulic brake system
2. Regenerative brake system

Hydraulic brake system

The hydraulic brake system is similar to the brakes used on conventional vehicles.

The brake system has two separate hydraulic circuits. If one circuit malfunctions, you will still have braking at two wheels.

Regenerative brake system

The primary purpose of regenerative brake system is to provide some power to help recharge the Li-ion battery and extend driving range. A secondary benefit is “engine braking” that operates based on battery conditions.

In the D (Drive) position, when the accelerator is released, the regenerative brake system provides some deceleration and generates power for the Li-ion battery. Power is also generated when the brake pedal is applied.

When you put the shift lever in the B position and take your foot off the accelerator pedal, more regenerative brake is applied than in the D (Drive) position.

However, during high-speed driving you may feel that regenerative brake provides less deceleration than the engine braking in an ordinary vehicle. This is normal.

Less deceleration is provided by the regenerative brake system when the Li-ion battery is fully charged. Regenerative brake is automatically reduced when the Li-ion battery is fully charged to prevent the Li-ion battery from becoming overcharged. Regenerative brake is also automatically reduced when the battery temperature is high/low to prevent Li-ion battery damage.

The brake pedal should be used to slow or stop the vehicle depending on traffic or road conditions. The vehicle brakes are not affected by regenerative brake system operation.

NOTE:

- **When applying the regenerative brakes, you may hear a sound coming from the regenerative brake system. This is a normal operating characteristic of an EV (Electric vehicle).**
- **If the power switch position is in a position other than ON or READY to drive, you can stop the vehicle by depressing the brake pedal. However, greater foot pressure on the brake pedal will be required to stop**

the vehicle, and the stopping distance will be longer.

- When depressing the brake pedal, the braking pedal feel will not be smooth or may change when the cooperative regenerative brake system activates. However, the electronically controlled brake system is operating normally and this does not indicate a malfunction.

Using the brakes

Avoid resting your foot on the brake pedal while driving. This will cause overheating of the brakes, wearing out the brake pads faster and will reduce driving range.

To help reduce brake wear and to prevent the brakes from overheating, reduce speed and select the B position before going down a slope or long grade. Overheated brakes may reduce braking performance and could result in loss of vehicle control.



WARNING

- While driving on a slippery surface, be careful when braking or accelerating. Abrupt braking or accelerating could cause the wheels to skid, which could result

in an accident.

- If the brake pedal is depressed with the EV (Electric Vehicle) system OFF, you may feel an increased brake pedal effort and a decreased pedal stroke. If the brake warning light (red) does not illuminate and the brake pedal feels like it has returned to its normal state after the EV system is started, this indicates that there is no malfunction and the vehicle can be operated normally.

Wet brakes

When the vehicle is washed or driven through water, the brakes may get wet. As a result, your braking distance will be longer and the vehicle may pull to one side during braking.

To dry brakes, drive the vehicle at a safe speed while lightly tapping the brake pedal to heat-up the brakes. Do this until the brakes return to normal. Avoid driving the vehicle at high speeds until the brakes function correctly.

BRAKE ASSIST

BRAKE ASSIST

When the force applied to the brake pedal exceeds a certain level, the Brake Assist is activated generating greater braking force than a conventional brake booster even with light pedal force.



WARNING

The Brake Assist is only an aid to assist braking operation and is not a collision warning or avoidance device. It is the driver's responsibility to stay alert, drive safely and be in control of the vehicle at all times.

ANTI-LOCK BRAKING SYSTEM (ABS)



WARNING

- The Anti-lock Braking System (ABS) is a sophisticated device, but it cannot prevent accidents resulting from careless or dangerous driving techniques. It can help maintain vehicle control during braking on slippery surfaces. Remember that stopping distances on slippery surfaces will be longer than on normal sur-

faces even with ABS. Stopping distances may also be longer on rough, gravel or snow covered roads, or if you are using tire chains. Always maintain a safe distance from the vehicle in front of you. Ultimately, the driver is responsible for safety.

- Tire type and condition may also affect braking effectiveness.
 - When replacing tires, install the specified size of tires on all four wheels.
 - For detailed information, see “Wheels and tires” (P.8-18) of this manual.

The Anti-lock Braking System (ABS) controls the brakes so the wheels do not lock during hard braking or when braking on slippery surfaces. The system detects the rotation speed at each wheel and varies the brake fluid pressure to prevent each wheel from locking and sliding. By preventing each wheel from locking, the system helps the driver maintain steering control and helps to minimize swerving and spinning on slippery surfaces.

Using the system

Depress the brake pedal and hold it down. Depress the brake pedal with firm steady pressure, but do not pump the brakes. The ABS will operate to prevent the wheels from locking up. Steer the vehicle to avoid obstacles.



WARNING

Do not pump the brake pedal. Doing so may result in increased stopping distances.

Self-test feature

The ABS includes electronic sensors, electric pumps, hydraulic solenoids and a computer. The computer has a built-in diagnostic feature that tests the system each time you push the power switch in the READY to drive position and move the vehicle at a low speed in forward or reverse. When the self-test occurs, you may hear a “clunk” noise and/or feel a pulsation in the brake pedal. This is normal and does not indicate a malfunction. If the computer senses a malfunction, it switches the ABS off and illuminates the ABS warning light on the instrument panel. The brake system then operates normally, but without anti-lock

assistance.

If the ABS warning light illuminates during the self-test or while driving, have the vehicle checked. It is recommended you visit a NISSAN certified ARIYA dealer for this service.

Normal operation

The ABS operates at speeds above 3 to 6 MPH (5 to 10 km/h). The speed varies according to road conditions.

When the ABS senses that one or more wheels are close to locking up, the actuator rapidly applies and releases hydraulic pressure. This action is similar to pumping the brakes very quickly. You may feel a pulsation in the brake pedal and hear a noise from under the hood or feel a vibration from the actuator when it is operating. This is normal and indicates that the ABS is operating properly. However, the pulsation may indicate that road conditions are hazardous and extra care is required while driving.

VEHICLE DYNAMIC CONTROL (VDC) SYSTEM

The Vehicle Dynamic Control (VDC) system uses various sensors to monitor driver inputs and vehicle motion. Under certain driving conditions, the VDC system helps to perform the following functions.



- Controls brake pressure to reduce wheel slip on one slipping drive wheel so power is transferred to a non slipping drive wheel on the same axle.
- Controls brake pressure and EV system output to reduce drive wheel slip based on vehicle speed (traction control function).
- Controls brake pressure at individual wheels and EV system output to help the driver maintain control of the vehicle in the following conditions:
 - understeer (vehicle tends to not follow the steered path despite increased steering input)
 - oversteer (vehicle tends to spin due to certain road or driving conditions).

The VDC system can help the driver to maintain control of the vehicle, but it cannot prevent loss of vehicle control in all driving situations.

When the VDC system operates, the slip indicator light  in the instrument panel flashes so note the following:

- The road may be slippery or the system may determine some action is required to help keep the vehicle on the steered path.
- You may feel a pulsation in the brake pedal and hear a noise or vibration from under the hood. This is normal and indicates that the VDC system is working properly.
- Adjust your speed and driving to the road conditions.

If a malfunction occurs in the system, the slip indicator light  illuminates in the instrument panel. The VDC system automatically turns off.

The vehicle information display is used to turn off the VDC system. The VDC off indicator  illuminates to indicate the VDC system is off. When the VDC system is turned off, the VDC system still operates to prevent one drive wheel from slipping by transferring power to a non slipping drive wheel. The slip indicator light  flashes if this occurs. All other VDC functions are off, and the slip indicator light  will not flash. The VDC system is automatically reset to on when the power switch is placed in the off position then back to the on position.

See “Slip indicator light” (P.2-19) and “Vehicle Dynamic Control (VDC) off indicator light” (P.2-19).





The computer has a built-in diagnostic feature that tests the system each time you start the EV system and move the vehicle forward or in reverse at a slow speed. When the self-test occurs, you may hear a “clunk” noise and/or feel a pulsation in the brake pedal. This is normal and is not an indication of a malfunction.



WARNING

- **The VDC system is designed to help improve driving stability but does not prevent accidents due to abrupt steering operation at high speeds or by careless or dangerous driving techniques. Reduce vehicle speed and be especially careful when driving and cornering on slippery surfaces and always drive carefully.**
- **Do not modify the vehicle's suspension. If suspension parts such as shock absorbers, struts, springs, stabilizer bars, bushings and wheels are not NISSAN recommended for your vehicle or are extremely deteriorated, the VDC system may not operate properly. This could adversely affect vehicle handling performance, and the slip indicator light**

 may illuminate.

- If brake related parts such as brake pads, rotors and calipers are not NISSAN recommended or are extremely deteriorated, the VDC system may not operate properly and the slip indicator light  may illuminate.
- If EV system control related parts are not NISSAN recommended or are extremely deteriorated, the slip indicator light  may illuminate.
- When driving on extremely inclined surfaces such as higher banked corners, the VDC system may not operate properly and the slip indicator light  may illuminate. Do not drive on these types of roads.
- When driving on an unstable surface such as a turntable, ferry, elevator or ramp, the slip indicator light  may illuminate. This is not a malfunction. Restart the EV system after driving onto a stable surface.
- If wheels or tires other than the NISSAN recommended ones are used, the VDC system may not operate properly and the slip

indicator light  may illuminate.

- The VDC system is not a substitute for winter tires or tire chains on a snow covered road.

HOW TO TURN OFF THE VDC SYSTEM

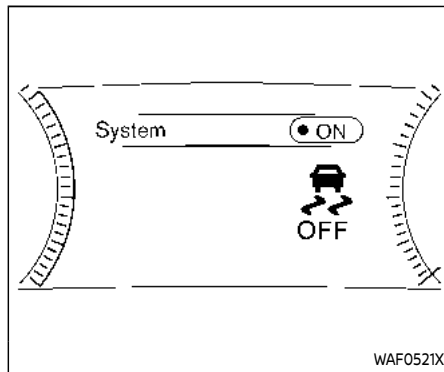

The vehicle should be driven with the Vehicle Dynamic Control (VDC) system ON for most driving conditions.

When the vehicle is stuck in mud or snow, the VDC system reduces the EV system output to reduce wheel spin. The EV system speed will be reduced even if the accelerator is depressed to the floor. If maximum EV system power is needed to free a stuck vehicle, turn the VDC system off.



Example

To turn off the VDC system, perform the following steps in the vehicle information display.

1. Push the   button on the steering wheel until "Settings" appears and then push the job dial.
2. Use the scroll dial to select "VDC Setting" and then push it.
3. Select "System" and push the scroll dial. The  indicator light will illuminate.



Turn "VDC Setting" back on in the vehicle information display or restart the EV system to turn on the VDC system.











BRAKE FORCE DISTRIBUTION



During braking while driving through turns, the system optimizes the distribution of force to each of the four wheels depending on the radius of the turn.



WARNING

- The VDC system is designed to help the driver maintain stability but does not prevent accidents due to abrupt steering operation at high speeds or by careless or dangerous driving techniques. Reduce vehicle speed and be especially careful when driving and cornering on slippery surfaces and always drive carefully.
- Do not modify the vehicle's suspension. If suspension parts such as shock absorbers, struts, springs, stabilizer bars, bushings and wheels are not NISSAN recommended for your vehicle or are extremely deteriorated, the VDC system may not operate properly. This could adversely affect vehicle handling performance, and the  indicator light may flash or both the  and  indicator lights may illuminate.

- If brake related parts such as brake pads, rotors and calipers are not NISSAN recommended or are extremely deteriorated, the VDC system may not operate properly and both the  and  indicator lights may illuminate.
- If EV system control related parts are not NISSAN recommended or are extremely deteriorated, both the  and  indicator lights may illuminate.
- When driving on extremely inclined surfaces such as higher banked corners, the VDC system may not operate properly and the  indicator light may flash or both the  and  indicator lights may illuminate. Do not drive on these types of roads.
- When driving on an unstable surface such as a turntable, ferry, elevator or ramp, the  indicator light may flash or both the  and  indicator lights may illuminate. This is not a malfunction. Restart the EV system after driving onto a stable surface.
- If wheels or tires other than the NISSAN recommended ones are

used, the VDC system may not operate properly and the  indicator light may flash or both the  and  indicator lights may illuminate.

- The VDC system is not a substitute for winter tires or tire chains on a snow covered road.

CHASSIS CONTROL

The chassis control is an electric control module that includes the following functions:

- Intelligent Trace Control

INTELLIGENT TRACE CONTROL

This system senses driving based on the driver's steering and acceleration/braking patterns, and controls brake pressure at individual wheels, driving torque control* and driving torque distribution control* to aid tracing at corners and help smooth vehicle response. (*: Only equipped for AWD models)

The Intelligent Trace Control can be set to ON (enabled) or OFF (disabled) using the "Driver Assistance" settings in the vehicle information display. (Driving torque distribution control* is not turned off.) (*: Only equipped for AWD models) (See "Settings" (P.2-25).)

When the VDC system is turned off, the Intelligent Trace Control is also turned off. (Even if the VDC is turned off to escape muddy or snowy roads, driving torque distribution control* will not be turned off to ensure traction.) Amount of the Intelligent Trace Control is changed based on the mode selected by the Drive Mode Selector.

(*: Only equipped for AWD models)

Amount of brake control is changed

depending on the mode selected by the Drive Mode selector.

When the Intelligent Trace Control is not functioning properly, the master warning light illuminates, and the warning message "Chassis Control System Error" will also appear in the vehicle information display.

If the chassis control warning message appears in the vehicle information display, it may indicate that the Intelligent Trace Control is not functioning properly. Have the system checked as soon as possible. It is recommended that you visit a NISSAN certified ARIYA dealer for this service. (See "Vehicle information display warnings and indicators" (P.2-34).)



WARNING

The Intelligent Trace Control may not be effective depending on the driving condition. Always drive carefully and attentively.

When the Intelligent Trace Control is operating, you may feel a pulsation in the brake pedal and hear a noise. This is normal and indicates that the Intelligent Trace Control is operating properly. You may also feel deceleration when the

Intelligent Trace Control is operating. However, this is not a malfunction.

HILL START ASSIST SYSTEM



WARNING

- **Never rely solely on the hill start assist system to prevent the vehicle from moving backward on a hill. Always drive carefully and attentively. Depress the brake pedal when the vehicle is stopped on a steep hill. Be especially careful when stopped on a hill on frozen or muddy roads. Failure to prevent the vehicle from rolling backwards may result in a loss of control of the vehicle and possible serious injury or death.**
- **The hill start assist system is not designed to hold the vehicle at a standstill on a hill. Depress the brake pedal when the vehicle is stopped on a steep hill. Failure to do so may cause the vehicle to roll backwards and may result in a collision or serious personal injury.**
- **The hill start assist system may not prevent the vehicle from rolling backwards on a hill under all load or road conditions. Always be prepared to depress the brake pedal to prevent the vehicle from rolling backwards. Failure to do**

so may result in a collision or serious personal injury.

The hill start assist system automatically keeps the brakes applied to help prevent the vehicle from rolling backwards in the time it takes the driver to release the brake pedal and apply the accelerator when the vehicle is stopped on a hill.

The hill start assist system will operate automatically under the following conditions:

- The transmission is shifted to a forward or reverse gear.
- The vehicle is stopped completely on a hill by applying the brake.

The maximum holding time is 2 seconds. After 2 seconds the vehicle will begin to roll back and the hill start assist system will stop operating completely.

The hill start assist system will not operate when the transmission is shifted to the N (Neutral) or P (Park) position or on a flat and level road.

When the slip indicator light illuminates in the meter, the hill start assist system will not operate. (See "Slip indicator light" (P.2-19).)

SONAR SYSTEM

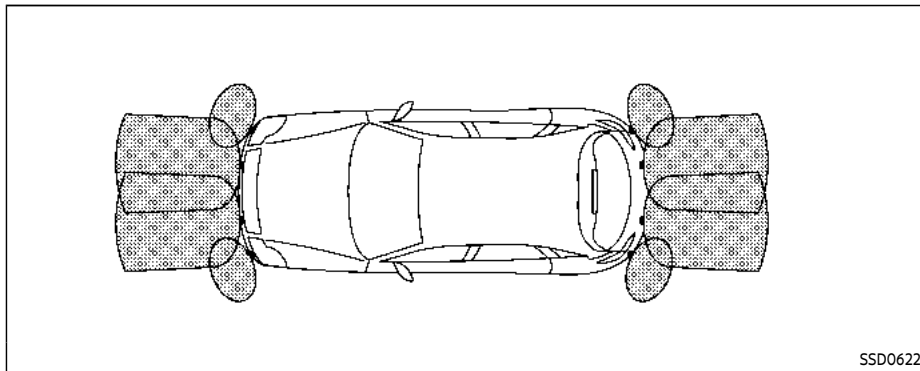

The sonar system sounds a tone to inform the driver of obstacles near the bumper.

When the sonar system is turned on, the sonar view will automatically appear in the vehicle information display and in the center display.



WARNING

- The sonar system is a convenience but it is not a substitute for proper parking.
- The driver is always responsible for safety during parking and

other maneuvers. Always look around and check that it is safe to do so before parking.

- If there is any doubt the surroundings in the path of the parking area and/or the parking area itself are not free from obstacles, immediately stop the vehicle and check the surroundings.
- The sonar system is intended as an aid to parking, to be used in conjunction with the inside and outside mirrors.

- Read and understand the limitations of the sonar system as contained in this section. The colors of the sonar indicator indicates different distances to the object.
- Inclement weather or ultrasonic sources such as an automatic car wash, a truck's compressed-air brakes or a pneumatic drill may affect the function of the system; this may include reduced performance or a false activation.
- The sonar system is designed as an aid to the driver in detecting large stationary objects to help avoid damaging the vehicle.
- The sonar system is not designed to prevent contact with small or moving objects. Always move slowly. The system will not detect small objects below the bumper, and may not detect objects close to the bumper or on the ground.
- The sonar system may not detect the following objects: fluffy objects such as snow, cloth, cotton, glass-wool, etc.; thin objects such as rope, wire and chain, etc.; or wedge-shaped objects.

- The front and rear sonar sensors detect the distance between the vehicle and the obstacle by detecting the sound wave reflected from the surface of an obstacle. When there is a sound such as horn, or an ultrasonic source (such as sonar of other vehicles) around the vehicle, the sensor (sonar) may not detect objects properly.
- The sonar system may detect some types of curbstones.

If your vehicle sustains damage to the bumper fascia, leaving it misaligned or bent, the sensing zone may be altered causing inaccurate measurement of obstacles or false alarms.



CAUTION

- Excessive noise (such as audio system volume or an open vehicle window) will interfere with the tone and it may not be heard.
- Keep the sonar sensors (located on the bumper fascia) free from snow, ice and large accumulations of dirt. Do not clean the sonar sensors with sharp objects.

If the sensors are covered, the accuracy of the sonar function will be diminished.

SYSTEM OPERATION

The system informs with a visual and audible signal of front obstacles when the shift lever is in the "D" (Drive) position and both front and rear obstacles when the shift lever is in the "R" (Reverse) position.

The system is deactivated at speeds above 6 MPH (10 km/h). It is reactivated at lower speeds.

The intermittent tone will stop after 3 seconds when an obstacle is detected by only the corner sensor and the distance does not change. The tone will stop when the obstacle get away from the vehicle.

When the object is detected, the indicator (green) appears and blinks and the tone sounds intermittently. When the vehicle moves closer to the object, the color of the indicator turns yellow and the rate of the blinking increases. When the vehicle is very close to the object, the indicator stops blinking and turns red, and the tone sounds continuously.

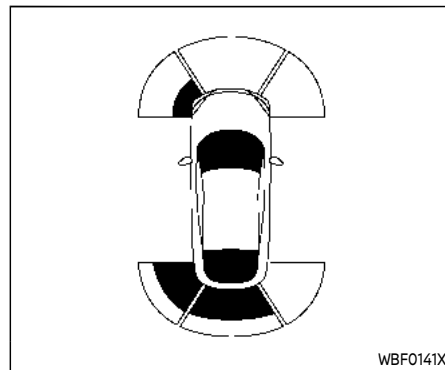

When the vehicle moves closer to an obstacle, the sonar indicator (detected area) appears in the vehicle information display.

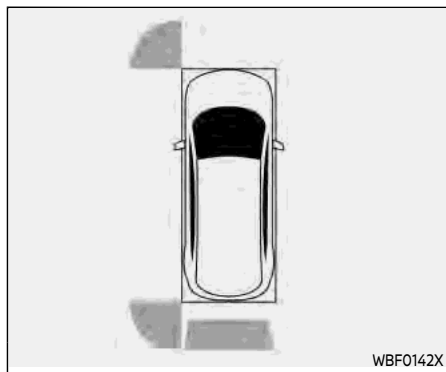

The sonar indicator also appears on the camera view of the center display.

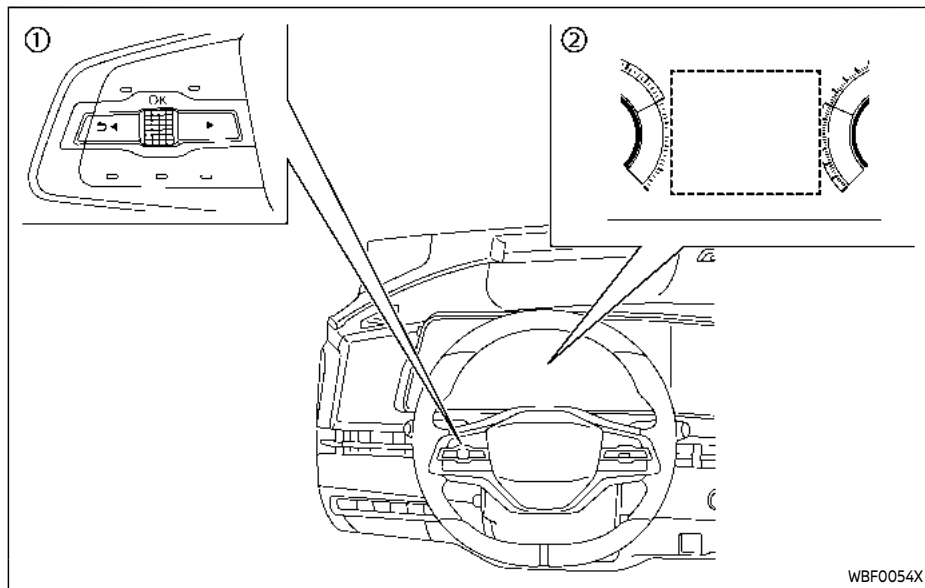

- ① Steering-wheel-mounted control (left side)
- ② Vehicle information display

HOW TO ENABLE/DISABLE THE SONAR SYSTEM

The system is automatically activated when the power switch is in the ON position and the shift lever is in the D (Drive) or R (Reverse) position.

NOTE:

When the shift lever is in the R (Reverse) position and the [Parking Assist] screen is displayed in the vehicle information display the sonar system can be disabled temporarily by pushing the scroll dial on the steering wheel.

Perform the following steps to set up the sonar system function.

1. Push the ◀ ▶ button until "Settings" appears in the vehicle information display and then push the scroll dial. Use the scroll dial to select "Driver Assistance." Then push the scroll dial.
2. Select "Parking Assist" and push the scroll dial.
3. Use the scroll dial to navigate in the menu and select or change an item:
 - Front Sonar
 - Turns ON/OFF the front sonar sensors
 - Rear Sonar
 - Turns ON/OFF the rear sonar sensors

NOTE:

Disabling Rear Sonar will not automatically disable Rear Automatic Braking (RAB). To activate/deactivate RAB, see "How to enable/disable Rear Automatic Braking" (P.5-144).

- Sonar Distance
 - Changes the sonar sensor's detection distance to "Long," "Medium" or "Short"
- Auto Show Sonar
 - Shows the sonar display in the vehicle information display when the sonar activates
- Sonar Volume
 - Changes the volume of the tone sound to "High," "Medium" or "Low"

SONAR SYSTEM LIMITATIONS**WARNING**

Listed below are the system limitations for the sonar system. Failure to operate the vehicle in accordance with these system limitations could result in serious injury or death.

- Read and understand the limitations of the sonar system as contained in this section. Inclement weather may affect the function of the sonar system; this may include reduced performance or a false activation.
- The sonar system is deactivated at speeds above 6 MPH (10 km/h). It is reactivated at lower speeds.

- Inclement weather or ultrasonic sources such as an automatic car wash, a truck's compressed-air brakes or a pneumatic drill may affect the function of the sonar system; this may include reduced performance or a false activation.
- The sonar system is not designed to prevent contact with small or moving objects. Always move slowly. The system will not detect small objects below the bumper or on the ground.
- The sonar system may not detect the following objects: fluffy objects such as snow, cloth, cotton, glass-wool, etc.; thin objects such as rope, wire and chain, etc.; or wedge-shaped objects; complex-shaped objects or multiple objects in close.
- The sonar system may not detect objects at speed above 3 MPH (5 km/h) and may not detect certain angular or moving objects.
- The sonar system may not detect the following objects:
 - Pedestrians who approach the vehicle from the side

- Objects placed next to the vehicle
- The sonar system may not operate in the following conditions:
 - When rain, snow, ice, dirt, etc. adheres to the sonar sensors.
 - When a loud sound is heard in the area around the vehicle.
 - When the surface of the obstacle is diagonal to the front or rear of the vehicle.
 - When a sonar system or the area around the sensor is extremely hot or cold.
- The sonar system may unintentionally operate in the following conditions:
 - When there is overgrown grass in the area around the vehicle.
 - When there is a structure (for example, a wall, a toll gate equipment, a narrow tunnel or a parking lot gate) near the side of the vehicle.
 - When there are bumps, protrusions or manhole covers on the road surface.

- When the vehicle drives through a draped flag or a curtain.
- When there is an accumulation of snow or ice behind the vehicle.
- When driving on a steep hill.

SYSTEM TEMPORARILY UNAVAILABLE

When sonar blockage is detected, the system will be deactivated automatically.

The system is not available until the conditions no longer exist.

The sonar sensors may be blocked by temporary ambient conditions such as splashing water, mist or fog. The blocked condition may also be caused by objects such as ice, frost or dirt obstructing the sonar sensors.

Action to take:

When the above conditions no longer exist, the system will resume automatically.

See "Driver assistance troubleshooting guide" (P.5-36).

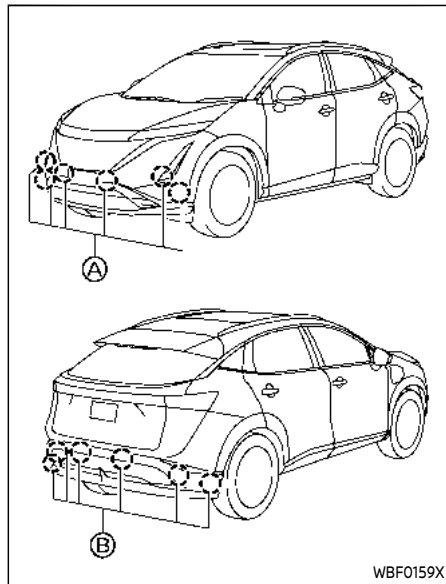

WBF0159X

SYSTEM MAINTENANCE

The sonar sensors ① and ② (8 or 12) are located on the front and rear bumpers.

- Always keep the area near the sonar sensors clean.
- If the sonar sensors are dirty, wipe them off with a soft cloth while being

PROPILOT PARK (if so equipped)

careful to not damage them.

- The sonar sensors may be blocked by temporary ambient conditions such as splashing water, mist or fog. The blocked condition may also be caused by objects such as ice, frost or dirt obstructing the sonar sensors. Check for and remove objects obstructing the area around the sonar sensors.
- Do not subject the area around the sonar sensors to strong impact. Also, do not remove or disassemble the sonar sensors. If the sonar sensors and peripheral areas are deformed in an accident, etc., have the sonar sensors checked. It is recommended that you visit a NISSAN certified ARIYA dealer for this service.
- Do not attach stickers (including transparent material), install accessories or apply additional paint on the sonar sensors and their surrounding areas. This may cause a malfunction or improper operation.
- When washing the vehicle using a high-pressure washer, do not apply direct washer pressure on the sonar sensors. This may cause a malfunction of the sonar sensors.

OVERVIEW

ProPILOT Park is a parking assist system that can help detect an available parking space and support parallel and perpendicular back-in parking maneuvers. Once activated, the system controls the accelerator, brake, steering wheel and shifting operations in order to support the series of parking operations.

To determine if your vehicle is equipped: ProPILOT Park will have a button near the shift lever similar to the image below:

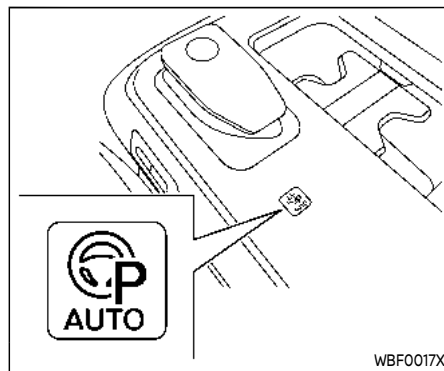

WARNING

Failure to follow the warnings and instructions for proper use of ProPILOT Park systems could result in serious injury or death.

- **ProPILOT Park systems are not a self-driving systems and are only capable within the limits as described in this manual.**
- **ProPILOT Park systems are not a replacement for proper driving procedures. It is a driver assistance system and is not intended to replace the driver. The driver is**

always responsible for the driving task.

- The ProPILOT Park System is designed to operate only under certain conditions. Accordingly the system may not always function as intended. It is the drivers responsibility to actively monitor the operation of the system and intervene as necessary.

How it works

ProPILOT Park uses some or all of the following components:

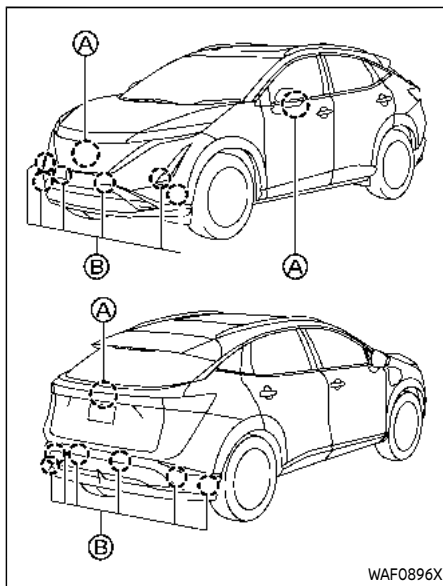

- Ⓐ Intelligent Around View® Monitor cameras (Front, Rear and Side):
Used to detect a parking space
- Ⓑ Sonar Sensors (Front, Side and Rear):
Used to detect parking space and surrounding objects

NOTE:

It is important to ensure the cameras and sonar sensors are clean before each drive. Unclean or damaged cameras and sensors, as well as environmental conditions can affect system performance.

WARNING

The sonar sensors system has some limitations. For details, see “Sonar system limitations” (P.5-163).

The Intelligent Around View® Monitor has some limitations. For details, see “Intelligent Around View® Monitor system limitations” (P.4-20).

WARNING

LIMITATIONS:

Many factors can impact the performance of ProPILOT Park causing the system not to perform as intended. ProPILOT Park should not be used in certain situations. These include (but are not limited to):

- Poor visibility due to heavy rain, snow, ice, fog, etc.

- Bright light (due to oncoming traffic, direct sunlight, etc.)
- Obstruction to sensors, and cameras caused by mud, dirt, ice, snow, etc.
- When using a trailer hitch (if so equipped)

ProPILOT Park may not react to:

- Stationary vehicles
- Pedestrians, bicycles or animals
- Road debris
- Road pylon in a construction zone

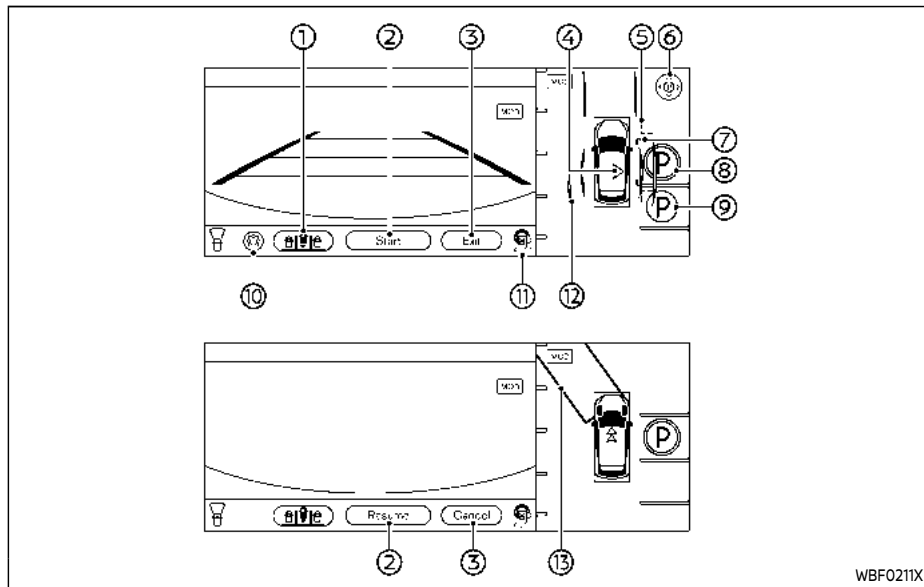

HOW TO OPERATE PROPILOT PARK

1. **Parking method selection icon:**

Indicates the parking method that is currently selected. Touch to change the parking method. Refer to "ProPILOT Park operation" (P.5-168).

2. **[Start]/[Resume]:**

Touch this key to start the ProPILOT Park control.

3. **[Exit]/[Cancel]:**

Touch this key to deactivate ProPILOT Park.

4. **Parking space detection icon:**

Indicates which side of parking space is detected during parking space search.

 : A parking space is detected on the right side.

 : A parking space is detected on the left side.

5. **Clearance Guidelines (Red):**

Indicates the approximate area that the vehicle will pass through when parking control is active.

6. **Parking guide box adjustment icon ():**

Touch this key to adjust the location of the parking guide box.

7. **Parking guide box (Green):**

This indicates the approximate position where the vehicle will be parked. The box turns light blue when parking control is active.

8. **P sign (Blue):**

Indicates the position where the vehicle will be parked.

9. **P sign (Colorless):**

Indicates a selectable parking position besides the selected parking position. When touched, the icon will change to blue.

10. **Settings icon ():**

Touch this icon to change the ProPILOT Park settings.

11. **ProPILOT Park control icon ():**

The ProPILOT Park control status is indicated by colors.

Green: The parking control is active.

Gray: The parking control is not active.



12. **Parking space search area guidelines (Light blue):**

Indicates that the system is currently searching for a parking space. Lines are also used as a guide for vehicle positioning during space searching. Refer to "Parking space detection requirements" (P.5-169).

13. **Direction change position rectangle (Green):**

Indicates the position at which to make the next shift change.

NOTE:

When the wipers are operating or when water or other substances on the camera lens is detected, the  sign is displayed. When the  sign is displayed, the detectable parking positions are restricted.

PROPILOT PARK OPERATION



1. Push the ProPILOT Park Switch .

- The ProPILOT Park display appears on the navigation system screen.
- ProPILOT Park can also be activated by touching [CAMERA] on the navigation system and then touching  on the Intelligent Around View Monitor screen.

NOTE:

Vehicle speed must be less than 18 MPH (29 km/h) to activate and search for an available parking space.

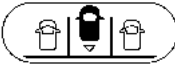
2. Select desired parking method by using the switch on the screen:

<p>Bay reverse parking</p> 	<p>Supports reversing into a parking space where vehicles are parked next to one another.</p>
<p>Parallel parking</p> 	<p>Supports reversing into a parking space where vehicles are parked in line with one another.</p>

3. Drive forward slowly while the system searches for a space:
 - When a parking space is detected, the system will provide a chime (in case of Sonar detection) and the indicator will appear.
 - Stop the vehicle next to the available space.
 - See page "Parking space detection requirements" (P.5-169) for detailed detection requirements.
4. Adjust space, if necessary
 - Using the arrows  to adjust target parking position as desired.
5. Keep the brake pedal depressed and touch [Start] on the screen.
 - The ProPILOT Park icon turns green and the brakes are applied automatically to keep the vehicle stopped.
 - Parking control cannot be started if the system detects an obstacle with the sonar sensors or cameras.
6. Release brake pedal and monitor surroundings:
 - Vehicle will move in the intended direction as indicated by the green rectangle.
 - Vehicle will control accelerator, brake, steering wheel and gear shift as necessary to complete the park-

ing maneuver.

- Parking control may be interrupted if an obstacle or object is detected in the intended path.
- For additional deactivation or cancellation conditions, see "Pause/deactivation of the system" (P.5-171).

NOTE:

Sonar system alerts are active during the parking maneuver.

7. Parking complete
 - When the vehicle is in the intended parking space as indicated by the blue rectangle, the parking maneuver is complete.
 - The shift position changes to P (Park) and the electronic parking brake is applied.
 - A sound and display will notify the driver when the parking control ends.



WARNING

- **It is the drivers responsibility to always park in a legal manner and obey all local and state regulations.**
- **Before exiting the vehicle, check that the electronic parking brake**

is activated and the shift position is in P (Park).

PARKING SPACE DETECTION REQUIREMENTS

The system may not be able to detect a parking space if :

- Distance from the vehicle to the parking position is too large
- Desired parking space is too large, too small, or too narrow
- Parking space markings are faded, covered or blocked
- The environment is too dark
- Curb is along a curved road
- Vehicle is on a high grade
- Rain or other substance blocking the cameras or sonar sensors

For additional conditions see "Pause/deactivation of the system" (P.5-171).

Parking position accuracy depends on the object position and angle and can vary based on the specific parking space.

Parallel Parking

The following conditions must be met for the system to detect an available parallel parking space:

- Vehicle must be within the following distances of the desired parking space:

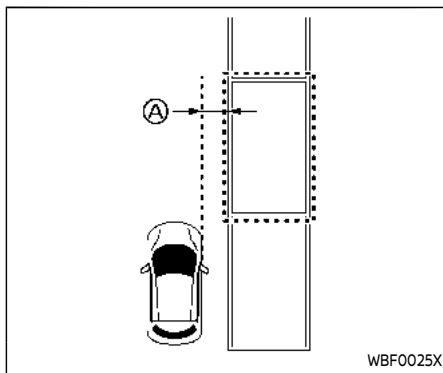

Ⓐ Approximately 3ft (1m)

- If the desired space is within painted parking lines, the system will attempt to position the vehicle within the painted lines. If painted lines aren't present, the system will use surrounding vehicles to position the vehicle within the space.

Perpendicular (Back-In) Parking

The following conditions must be met for the system to detect an available perpendicular parking space:

- Vehicle must be within the following distances of the desired parking space:

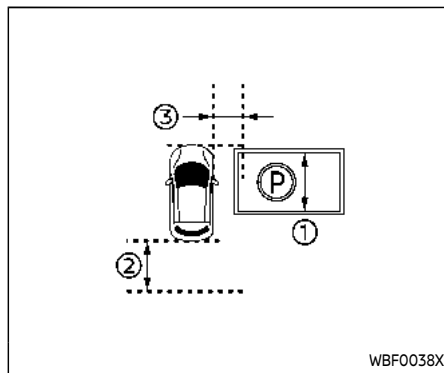

① Approximately 8 ft (2.3 m)

② Approximately 6 ft (2 m)

③ Approximately 3 ft (1 m)

- The desired space must have painted parking lines. The system will attempt to center the vehicle within the space, side to side. The system will attempt to align the front bumper with the end of the painted parking lines.

PAUSE/DEACTIVATION OF THE SYSTEM

To Pause the system:

- Apply the brake pedal. System will resume when brake pedal is released.

To Deactivate the system:

- Shift gears
- Apply steering wheel input
- Press the accelerator pedal

The system may have difficulty detecting a parking space, automatically pause or deactivate the system in any of the following conditions listed below. If the system pauses, the brakes are applied and the vehicle will stop. Parking control can be resumed by touching [Resume] on the screen while depressing the brake pedal after confirming that the conditions have been corrected. If the system deactivates, it is recommended to park the vehicle manually or move the vehicle to a more suitable position.

- An obstacle in the direction of travel was detected.
- The system determined the move to the parking position was not possible.
- The driver's seatbelt was unfastened.
- The electronic parking brake was activated.

- A door or liftgate was opened.
- 3 minutes or more have passed after ProPILOT Park was activated.
- 1 minute has passed after ProPILOT Park was paused.
- The vehicle drove 500 m or more after ProPILOT Park was activated.
- Vehicle speed exceeded approximately 19 MPH (30 km/h) during detection or 5 MPH (8 km/h) during parking maneuver.
- The outside mirrors were folded.
- The screen was switched by pressing the [MAP] or [Camera] button.
- The ProPILOT Park button was pushed.
- The VDC system was turned off.
- The VDC/TCS/ABS was activated.
- A system malfunction was detected.

PROPILOT PARK SETTINGS

To use the last selected type of parking:

Settings on the launch bar → Parking → Use the last selected type of parking → ON/OFF

- When this item is turned on, the parking method that was most recently used will be selected. When the item is turned off, parallel parking will be selected.

To detect parallel spaces on either side:

Settings on the launch bar → Parking → Detect Parallel parking spaces on both sides → ON/OFF

- When this item is turned on, parking positions on the both sides of the vehicle will be detected. When the item is turned off, only parking positions on the side last time ProPILOT Park used will be detected. If the turn signal switch is operated in this state, parking spaces on that side of the vehicle will be detected.

To enable/disable parking types:

Settings on the launch bar → Parking → Type Of Parking → Back In (perpendicular/Parallel)

The parking methods that are turned on can be selected each time the parking method selection icon is touched. The parking methods that are turned off cannot be selected by touching the parking method selection icon.



WARNING

ProPILOT Park LIMITATIONS

Many factors can impact the performance of ProPILOT Park causing the system to not perform as intended.

ProPILOT Park should not be used in certain situations. These include (but are not limited to):

- When there is rain, snow, ice, dirt or other substance adhering to the sonar sensors or camera lens.
- When people, children or animals enter the area.
- When there is a loud noise or thick grass in the surrounding area.
- When there is a structure (such as a wall, toll collection equipment, or parking gate) located nearby to the side of the vehicle.
- When there is a step, projecting object, or drain cover on the road.
- When under a hanging flag, plastic curtain, or similar object.
- When the surrounding area is dark, such as at night or in a parking garage.
- When parking space lines are not clearly visible.
- When parking on a steep hill, gravel, or unpaved roads.
- When strong light from the sun or streetlight shines on the road or camera.

- When there is a device generating ultrasound (including vehicles equipped with sonar sensors in the surrounding area.
- Under certain conditions it may be impossible or difficult to detect a parking position. As necessary, move the vehicle to a more suitable position.
- When the vehicle is equipped with non-original or winter tires. It is recommended that you visit your NISSAN certified ARIYA dealer.

NOTE:

If limitations are considered, all conditions are met and ProPILOT Park is still not functioning properly, it is recommended that you contact a NISSAN certified ARIYA dealer.

ProPILOT Park uses functions of Intelligent Around View® Monitor and Sonar System. It is important to understand limitations of these individual systems. For full troubleshoot guiding guide see "Intelligent Around View® Monitor system limitations" (P.4-20) and "Sonar system limitations" (P.5-163).

PROPILOT PARK MALFUNCTIONS

If there is an abnormality in the system, a warning message is displayed on the screen, the color of the ProPILOT Park control icon changes to orange, and ProPILOT Park is automatically deactivated. If a warning is displayed while the system is in use, stop the vehicle in a safe location and place the power switch in the OFF position and then place it back in the ON position. If it is not possible to activate ProPILOT Park after performing the above, there may be a malfunction in the system. This does not interfere with ordinary driving. However, the system should be inspected by a knowledgeable repairer such as a NISSAN certified ARIYA dealer.

COLD WEATHER DRIVING



WARNING

- Whatever the condition, drive with caution. Accelerate and decelerate with great care. If accelerating or decelerating too fast, the drive wheels will lose even more traction.
- Allow more stopping distance in cold weather driving. Braking should be started sooner than on dry pavement.
- Keep at a greater distance from the vehicle in front of you on slippery roads.
- Wet ice (32°F, 0°C and freezing rain), very cold snow and ice can be slick and very difficult to drive on. The vehicle will have a lot less traction or grip under these conditions. Try to avoid driving on wet ice until the road is salted or sanded.
- Watch for slippery spots (glaring ice). These may appear on an otherwise clear road in shaded areas. If a patch of ice is seen ahead, brake before reaching it. Try not to brake while actually on the ice, and avoid any sudden

steering maneuvers.

- Do not use cruise control on slippery roads.



CAUTION

To prevent damage to the Li-ion battery: Do not store a vehicle in temperatures below -13°F (-25°C) for over seven days. If the outside temperature is -13°F (-25°C) or less, the Li-ion battery may freeze and it cannot be charged or provide power to drive the vehicle. Move the vehicle to a warm location.

NOTE:

- Driving range may be substantially reduced in extremely cold conditions (for example under -4°F (-20°C)).
- Using the climate control system to heat the cabin when outside temperature is below 32°F (0°C) uses more electricity and affects driving range more than when using the heater when the temperature is above 32°F (0°C).

- The Li-ion battery requires more time to charge when the Li-ion battery temperature control system (if so equipped) operates.
- The Climate Ctrl. Timer does not turn on while the Li-ion battery temperature control system (if so equipped) operates.
- Set only the charging timer [End Time] when charging in cold weather. The vehicle automatically determines when to start charging, to fully charge the Li-ion battery, whether or not the Li-ion battery temperature control system (if so equipped) operates.

12-VOLT BATTERY

If the 12-volt battery is not fully charged during extremely cold weather conditions, the 12-volt battery fluid may freeze and damage the 12-volt battery. To maintain maximum efficiency, the 12-volt battery should be checked regularly. For additional information, see "12-volt battery" (P.8-11).

COOLANT

If the vehicle is to be left outside without anti-freeze, drain the cooling system. Refill before operating the vehicle. For details, see "Cooling system" (P.8-4).

TIRE EQUIPMENT

SUMMER tires have a tread designed to provide superior performance on dry pavement. However, the performance of these tires will be substantially reduced in snowy and icy conditions. If you operate your vehicle on snowy or icy roads, NISSAN recommends the use of MUD & SNOW or ALL SEASON tires on all four wheels. It is recommended you consult a NISSAN certified ARIYA dealer for the tire type, size, speed rating and availability information.

For additional traction on icy roads, studded tires may be used. However, some U.S. states and Canadian provinces prohibit their use. Check local, state and provincial laws before installing studded tires.

Skid and traction capabilities of studded snow tires, on wet or dry surfaces, may be poorer than that of non-studded snow tires.

Tire chains may be used. For details, see "Tire chains" (P.8-26) of this manual.

All-Wheel Drive (AWD) model

If you install snow tires, they must also be the same size, brand, construction and tread pattern on all four wheels.

SPECIAL WINTER EQUIPMENT

It is recommended that the following items be carried in the vehicle during the winter:

- A scraper and stiff-bristled brush to remove ice and snow from the windows.
- A sturdy, flat board to be placed under the jack to give it firm support.
- A shovel to dig the vehicle out of snowdrifts.

PARKING BRAKE

When parking in the area where the outside temperature is below 32°F (0°C), do not apply the parking brake to prevent it from freezing. For safe parking:

- Push the park button to place the vehicle in the P (Park) position.
- Securely block the wheels.

CORROSION PROTECTION

Chemicals used for road surface deicing are extremely corrosive and will accelerate corrosion and the deterioration of underbody components such as the brake lines, brake cables, floor pan and fenders.

In the winter, the underbody must be cleaned periodically. For additional information, see "Corrosion protection" (P.7-7).

For additional protection against rust and corrosion, which may be required in some areas, it is recommended that you consult a NISSAN certified ARIYA dealer.

FREEING A FROZEN CHARGE PORT LID

When the charge port is frozen, melt the ice.

ACTIVE SOUND ENHANCEMENT (AWD models)

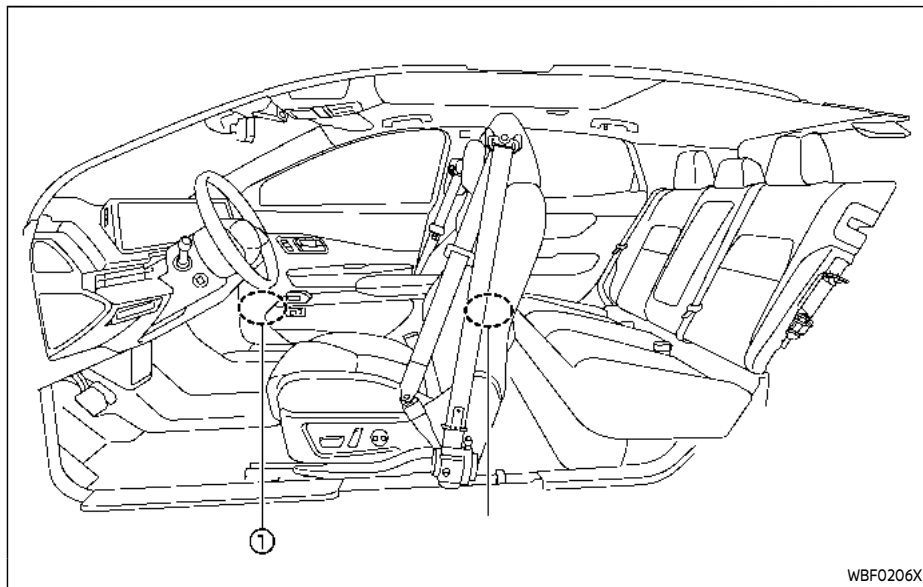

WBF0206X

NOTE:

To operate the active sound enhancement system properly:

- Do not cover the speakers.
- Do not change or modify speakers and any audio related parts such as the amplifier.
- Do not make any modification including sound deadening or modifications around the speakers.

The active sound enhancement generates sounds according to motor speed and driving modes through the speakers ① to enhance the quality of the motor sound.

MEMO

6 In case of emergency

Hazard warning flasher switch	6-2	Jump starting	6-15
Connection to Roadside Assistance	6-2	If the Li-ion battery becomes completely discharged	6-18
Emergency EV system shut off	6-3	Push starting	6-19
Flat tire	6-3	Towing your vehicle	6-20
Tire Pressure Monitoring System (TPMS)	6-3	Towing Recommended by NISSAN	6-21
Repairing flat tire	6-4	Vehicle recovery (freeing a stuck vehicle)	6-23
Jacking up vehicle and replacing tires	6-10		

HAZARD WARNING FLASHER SWITCH

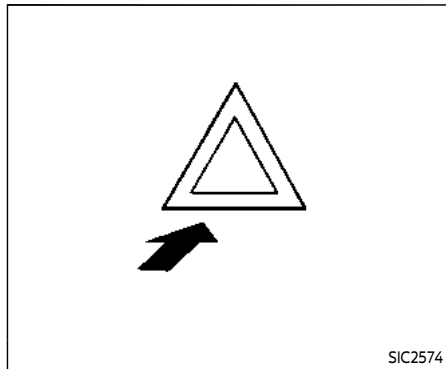

The hazard indicator flasher switch operates regardless of the power switch position except when the battery is discharged.

The hazard indicator flasher is used to warn other drivers when you have to stop or park under emergency conditions.

When the hazard indicator flasher switch is pushed, all turn signal lights will flash. To turn off the hazard indicator flasher, push the hazard indicator flasher switch again.

When an impact that could activate the supplemental air bags is detected, the hazard warning flasher lights blink automatically. If the hazard warning flasher

6-2 In case of emergency

switch is pushed, the hazard warning flashers will turn off.



WARNING

- **If stopping for an emergency, be sure to move the vehicle well off the road.**
- **Do not use the hazard warning flashers while moving on the highway unless unusual circumstances force you to drive so slowly that your vehicle might become a hazard to other traffic.**
- **Turn signals do not work when the hazard warning flasher lights are on.**



WARNING

Do not turn the hazard warning flasher switch to off until you can make sure that it is safe to do so. Also, the hazard flasher warning may not blink automatically depending on the force of impact.

CONNECTION TO ROADSIDE ASSISTANCE

In the event of a roadside emergency, Roadside Assistance Service is available to you. Please refer to your Warranty Information Booklet (U.S.) or Warranty & Roadside Assistance Information Booklet (Canada) for details.

EMERGENCY EV SYSTEM SHUT OFF

To shut off the EV system in an emergency situation while driving, perform the following procedure:

- Rapidly push the push-button power switch 3 consecutive times in less than 1.5 seconds, or
- Push and hold the push-button power switch for more than 2 seconds.

FLAT TIRE

TIRE PRESSURE MONITORING SYSTEM (TPMS)

This vehicle is equipped with the Tire Pressure Monitoring System (TPMS). It monitors tire pressure of all tires. When the low tire pressure warning light is lit, and the "Tire Pressure Low - Add Air" warning message is displayed in the vehicle information display, one or more of your tires is significantly under-inflated. If the vehicle is being driven with low tire pressure, the TPMS will activate and warn you of it by the low tire pressure warning light. This system will activate only when the vehicle is driven at speeds above 16 MPH (25 km/h). For more details, see "Warning lights, indicator lights and audible reminders" (P.2-11) and "Tire Pressure Monitoring System (TPMS)" (P.5-5).



WARNING

- Radio waves could adversely affect electric medical equipment. Those who use a pacemaker should contact the electric medical equipment manufacturer for the possible influences before use.
- If the low tire pressure warning light illuminates while driving,

avoid sudden steering maneuvers or abrupt braking, reduce vehicle speed, pull off the road to a safe location and stop the vehicle as soon as possible. Driving with under-inflated tires may permanently damage the tires and increase the likelihood of tire failure. Serious vehicle damage could occur and may lead to an accident and could result in serious personal injury. Check the tire pressure for all four tires. Adjust the tire pressure to the recommended COLD tire pressure shown on the Tire and Loading Information label to turn the low tire pressure warning light OFF. If the light still illuminates while driving after adjusting the tire pressure, a tire may be flat. If you have a flat tire, repair it with an emergency tire puncture repair kit as soon as possible.

- Replacing tires with those not originally specified by NISSAN could affect the proper operation of the TPMS.
- NISSAN recommends using only Genuine NISSAN Emergency Tire Sealant provided with your vehicle. Other tire sealants may da-

mage the valve stem seal which can cause the tire to lose air pressure. It is recommended that you visit a NISSAN certified ARIYA dealer as soon as possible after using tire repair sealant.

CAUTION

- The TPMS may not function properly when the wheels are equipped with tire chains or the wheels are buried in snow.
- Do not place metalized film or any metal parts (antenna, etc.) on the windows. This may cause poor reception of the signals from the tire pressure sensors, and the TPMS will not function properly.

Some devices and transmitters may temporarily interfere with the operation of the TPMS and cause the TPMS indicator light to illuminate. Some examples are:

- Facilities or electric devices using similar radio frequencies are near the vehicle.

– If a transmitter set to similar frequencies is being used in or near the vehicle.

– If a computer (or similar equipment) or a DC/AC converter is being used in or near the vehicle.

- When inflating the tires and checking the tire pressure, never bend the valves.
- Use Genuine NISSAN valve caps that comply with the factory-fitted valve cap specifications.
- Do not use metal valve caps.
- Fit the valve caps properly. Without the valve caps the valve and tire pressure monitor sensors could be damaged.
- Do not damage the valves and sensors when storing the wheels or fitting different tires.
- Replace the TPMS sensor valve stem (including valve core and cap) and screw (if so equipped) when the tires are replaced due to wear or age. The screw (if so equipped) must be fitted correctly with a torque setting of 1.4 ± 0.1 N.m. The TPMS sensors can be used again.

REPAIRING FLAT TIRE

WARNING

- After using Genuine NISSAN Emergency Tire Sealant to repair a minor tire puncture, do not drive the vehicle at speeds faster than 50 mph (80 km/h).
- Immediately after using the Genuine NISSAN Emergency Tire Sealant to repair a minor tire puncture, it is recommended that you visit a NISSAN certified ARIYA dealer. The Genuine NISSAN Emergency Tire Sealant cannot permanently seal a punctured tire. Continuing operation of the vehicle without a permanent tire repair can lead to a crash.
- If you used the Genuine NISSAN Emergency Tire Sealant to repair a minor tire puncture, it is recommended that you visit a NISSAN certified ARIYA dealer to replace the TPMS sensor in addition to repairing or replacing the tire.
- NISSAN recommends using only Genuine NISSAN Emergency Tire Sealant provided with your vehicle. Other tire sealants may da-

Damage the valve stem seal which can cause the tire to lose air pressure.

This vehicle does not have a spare tire. The emergency tire puncture repair kit (Genuine NISSAN Emergency Tire Sealant) is supplied with the vehicle instead of a spare tire. It can be used to temporarily repair minor tire punctures.

If possible, have the vehicle towed to a facility that can repair or replace the flat tire. Using the emergency tire puncture repair kit may cause a malfunction of the tire pressure sensor and cause the low tire pressure warning light to illuminate.



CAUTION

- **To avoid the emergency tire puncture kit being damaged during storage or use:**
 - Only use the emergency tire puncture repair kit on your vehicle. Do not use it on other vehicles.
 - Only use the kit to inflate the tires of your vehicle and to check the vehicle's tire pressure.

- Only plug the compressor into a 12-volt DC car power point.
- Keep the kit free of water and dirt.
- Do not disassemble or modify the kit.
- Do not drop the kit or allow hard impacts to the kit.
- **Do not use the emergency tire puncture repair kit under the following conditions. It is recommended that you visit a NISSAN certified ARIYA dealer or professional road assistance.**
 - when the sealant has passed its expiration date (shown on the label attached to the bottle)
 - when the cut or the puncture is approximately 0.20 in (5 mm) or longer
 - when the tire sidewall is damaged
 - when the vehicle has been driven with extremely low tire pressure
 - when the tire has come off the inside or the outside of the wheel

- when the tire wheel is damaged
- when two or more tires are flat

If you have a flat tire, follow the instructions below.

Stopping vehicle



WARNING

- **Make sure the parking brake is securely applied and the vehicle is placed into the "P" (Park) position.**
 - **Never repair tires when the vehicle is on a slope, ice or slippery area. This is hazardous.**
 - **Never repair tires when the oncoming traffic is close to your vehicle. Call for professional road assistance.**
1. Safely move the vehicle off the road away from traffic.
 2. Turn on the hazard indicator flasher lights.

3. Park on a level surface.
4. Apply the parking brake.
5. Push the park button to engage the "P" (Park) position.
6. Turn off the EV system.
7. Open the hood and set up the warning triangle (if so equipped):
 - To warn other traffic.
 - To signal professional road assistance personnel that you need assistance.
8. Have all passengers get out from the vehicle and stand in a safe place, away from other traffic and clear of the vehicle.

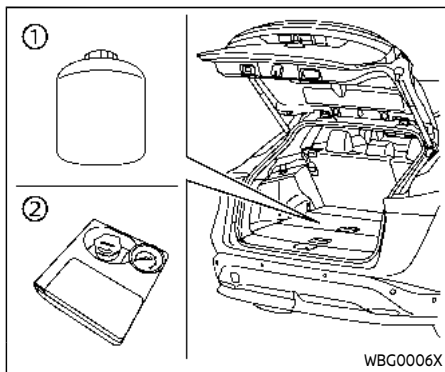

Getting emergency tire puncture repair kit

Take out the emergency tire puncture repair kit from the storage area under the luggage floor board. The repair kit consists of the following items:

- ① Tire sealant bottle
- ② Air compressor*

*: The compressor shape may differ depending on the models.

Before using emergency tire puncture repair kit

- If any foreign object (for example, a screw or nail) is embedded in the tire, do not remove it.
- Check the expiration date of the sealant (shown on the label attached to the bottle). Never use a sealant whose expiration date has passed.

Repairing tire



WARNING

Observe the following precautions when using the emergency tire puncture repair kit.

- **Swallowing the compound is dangerous. Immediately drink as much water as possible and seek prompt medical assistance.**
- **Rinse well with lots of water if the compound comes into contact with skin or eyes. If irritation persists, seek prompt medical attention.**
- **Keep the repair compound out of the reach of children.**
- **The emergency repair compound may cause a malfunction of the**

tire pressure sensors and cause the low tire pressure warning light to illuminate. Have the tire pressure sensor replaced as soon as possible.

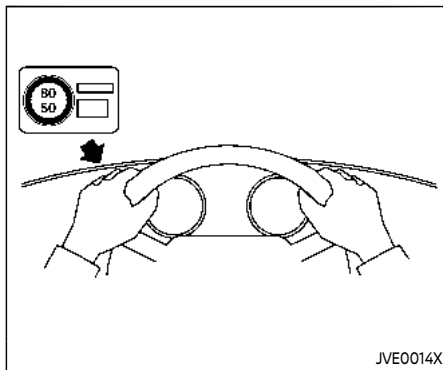

1. Take out the speed restriction sticker from the air compressor*, then put it in a location where the driver can see it while driving.

*: The compressor shape may differ depending on the models.



CAUTION

Do not put the speed restriction label on the steering wheel pad, the speedometer or the warning light locations.

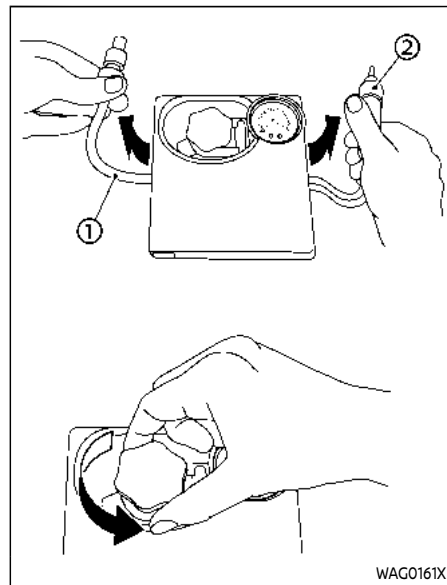

2. Take the hose ① and the power plug ② out of the air compressor. Remove the cap of the bottle holder from the air compressor.

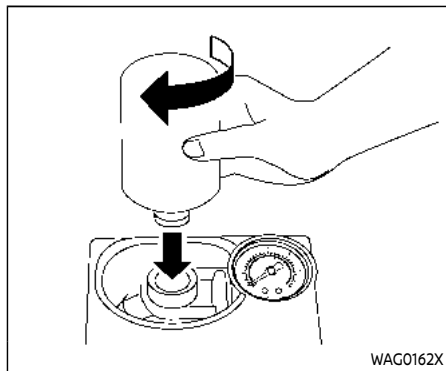

3. Remove the cap of the tire sealant bottle, and screw the bottle clockwise onto the bottle holder. (Leave the bottle seal intact. Screwing the bottle onto the bottle holder will pierce the seal of the bottle.)
4. Remove the cap of the tire valve on the flat tire.

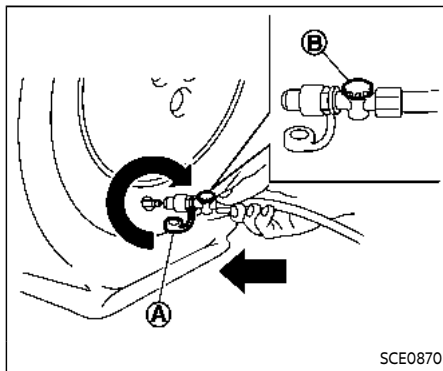

5. Remove the protective cap **A** of the hose and screw the hose securely onto the tire valve. Make sure that the pressure release valve **B** is securely tightened. Make sure that the air compressor switch is in the OFF (○) position, and then insert its power plug into the power outlet in the vehicle.

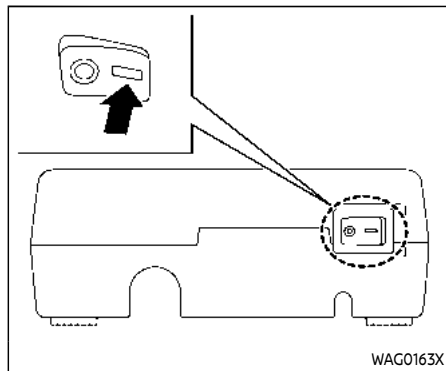

6. Place the power switch in the "ON" position. Then turn the compressor switch to the ON (-) position and inflate the tire up to the pressure that is specified on the Tire and Loading Information label affixed to the driver's side center pillar if possible, or to the minimum of 26 psi (180 kPa). Turn the air compressor off briefly in order to check the tire pressure with the pressure gauge.

If the tire is inflated to higher than the specified pressure, adjust the tire pressure by releasing air with the pressure release valve. The cold tire pressures are shown on the Tire and Loading Information label affixed to

the driver's side center pillar.



CAUTION

- An incomplete connection between the hose and tire valve causes air leakage or sealant scatter.
- Do not stand directly beside the damaged tire while it is being inflated because of the risk of the rupture. If there are any cracks or bumps, turn the compressor off immediately.
- There is a possibility that the pressure reaches 87 psi (600 kPa) while the tire is being inflated, but it is normal condition. Usually the pressure will drop in about 30 seconds.
- Do not operate the compressor for more than 10 minutes.

If the tire pressure does not increase to **26 psi (180 kPa) within 10 minutes**, the tire may be seriously damaged and **the tire cannot be repaired with this tire puncture repair kit**. It is recommended that you contact a NISSAN certified ARIYA dealer.

7. When the tire pressure is reaching the specified pressure or is at the minimum of 26 psi (180 kPa), turn the air compressor off. Remove the power plug from the power outlet and quickly remove the hose from the tire valve. Attach the protective cap and valve cap.



CAUTION

Leave the tire sealant bottle on the bottle holder in order to prevent sealant from spilling out.

8. Immediately drive the vehicle for 10 minutes or 2 miles (3 km) at a speed of 50 MPH (80 km/h) or less.
9. After driving, make sure that the air compressor switch is in the OFF (○) position, then screw the hose securely onto the tire valve. Check the tire pressure with the pressure gauge.

If the tire pressure drops under 19 psi (130 kPa):

The tire cannot be repaired with this tire puncture repair kit. It is recommended that you contact a NISSAN certified ARIYA dealer.

If the tire pressure is 19 psi (130 kPa) or more but less than the specified pressure:

Turn the compressor switch to the ON (—) position and inflate the tire up to the specified pressure. Then repeat the steps from 8.

If the pressure drops again, **the tire cannot be repaired with this tire puncture repair kit**. It is recommended that you contact a NISSAN certified ARIYA dealer.

When the tire pressure is the specified pressure:

The temporary repair is completed.

It is recommended that you visit a NISSAN certified ARIYA dealer for tire repair/replacement as soon as possible.



CAUTION

Do not reuse the tire sealant bottle or the hose.

For a new tire sealant bottle and hose, it is recommended that you contact a NISSAN certified ARIYA dealer.

After repairing tire

It is recommended that you visit a NISSAN certified ARIYA dealer for tire repair/replacement as soon as possible.

JACKING UP VEHICLE AND REPLACING TIRES

This section provides the information about the vehicle jack-up procedures and the tire replacement.

You can temporarily fix a minor tire puncture using the emergency tire puncture repair kit. (See "Repairing flat tire" (P.6-4).)



WARNING

- Be sure to apply the parking brake firmly.
- Be sure to push the park button to engage the "P" (Park) position.
- Never change tires when the vehicle is on a slope, ice or slippery area. This is hazardous.
- Never change tires when the oncoming traffic is close to your vehicle. Call for professional road assistance.

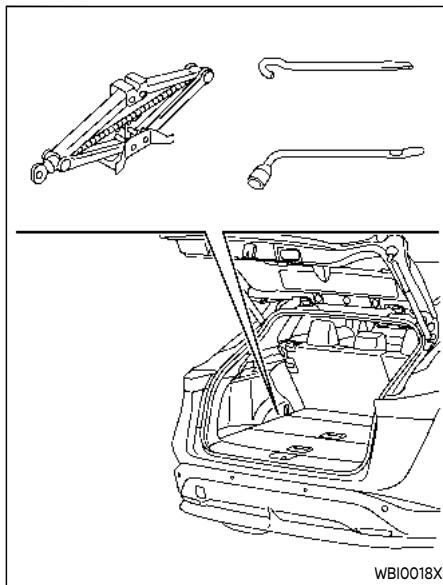

Preparing tools

Open the liftgate. Raise the luggage floor board. Remove the jacking tools.

The jack, jack rod and wheel nut wrench are not equipped as standard with this vehicle. It is recommended that you contact a NISSAN certified ARIYA dealer

about acquiring the tools.



CAUTION

Do not touch floor metal directly. Doing so could result in any burns.

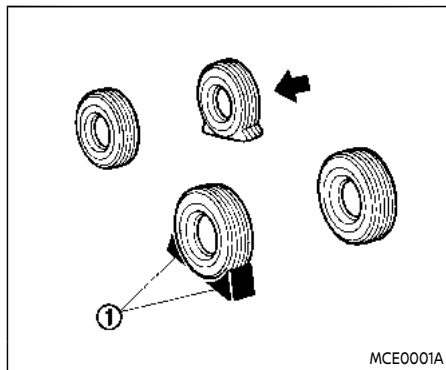

Blocking wheels

WARNING

Be sure to block the appropriate wheel to prevent the vehicle from moving, which may cause personal injury.

Place suitable blocks ① at both the front and back of the wheel diagonally opposite the flat tire ← to prevent the vehicle from moving when it is jacked up.

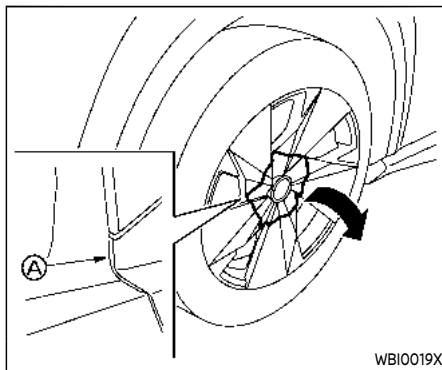

Removing tire

Removing wheel center cover (models with 20 inch wheel):

WARNING

Never use your hands to remove the wheel cover. This may cause personal injury.

To remove the wheel center cover, insert a suitable tool to the point Ⓐ and pry the cover off.

Apply cloth between the wheel and a tool

to prevent damaging the wheel and wheel cover.

CAUTION

Do not remove plastic parts other than the center cover on the wheel. Doing so may damage the plastic parts and the wheel.

Jacking up vehicle:

WARNING

- Never get under the vehicle while it is supported only by the jack. If it is necessary to work under the vehicle, support it with safety stands.
- Use only the jack provided with your vehicle to lift the vehicle. Do not use the jack provided with your vehicle on other vehicles. The jack is designed for lifting only your vehicle during a tire change.
- Use the correct jack-up points. Never use any other part of the vehicle for jack support.

- Never jack up the vehicle more than necessary.
- Never use blocks on or under the jack.
- Do not start or run the EV system while vehicle is on the jack, as it may cause the vehicle to move.
- Do not allow passengers to stay in the vehicle while it is on the jack.

Carefully read the caution label attached to the jack body and the following instructions.

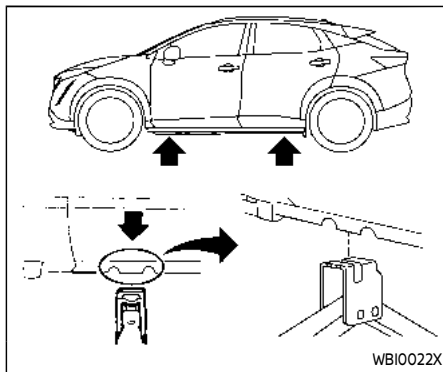

jack-up points

1. Place the jack directly under the jack-up point as illustrated so the top of the jack contacts the vehicle at the jack-up point. Align the jack head between the two notches in the front or the rear as shown. Also fit the groove of the jack head between the notches as shown.

The jack should be used on firm and level ground.

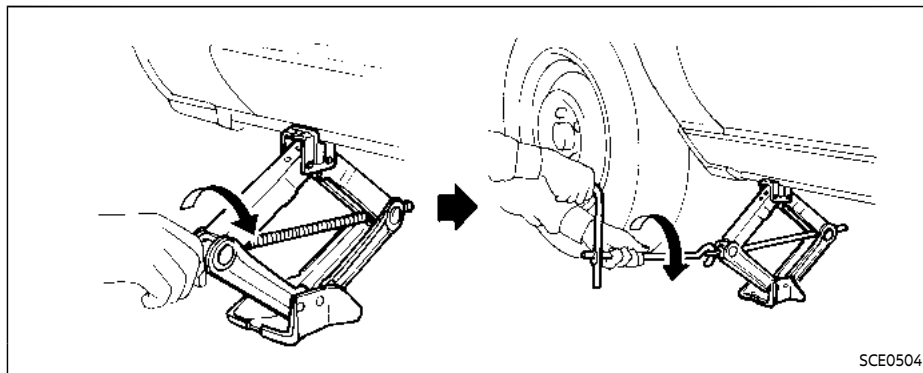

2. Loosen each wheel nut one or two turns by turning it counterclockwise with the wheel nut wrench. **Do not remove the wheel nuts until the tire is off the ground.**
3. To lift the vehicle, securely hold the jack lever and rod with both hands as shown above. Carefully raise the vehicle until the tire clears the ground. Remove the wheel nuts, and then remove the tire.

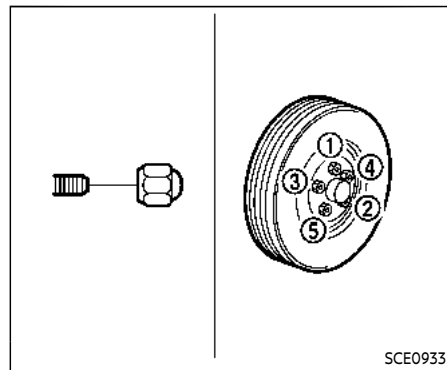

Installing tire



WARNING

- Never use wheel nuts which are not provided with your vehicle. Incorrect wheel nuts or improperly tightened wheel nuts may cause the wheel to become loose or come off. This could cause an accident.
- Never use oil or grease on the wheel studs or nuts. This may cause the wheel nuts to become loose.

1. Clean any mud or dirt from the surface between the wheel and hub.
2. Carefully put the tire on and tighten the wheel nuts with your fingers. Check that all the wheel nuts contact the wheel surface horizontally.
3. Tighten the wheel nuts alternately and evenly, more than 2 times in the sequence illustrated (① - ⑤), with the wheel nut wrench, until they are tight.
4. Lower the vehicle slowly until the tire touches the ground.
5. Tighten the wheel nuts securely, with the wheel nut wrench, in the sequence illustrated.
6. Lower the vehicle completely.

Tighten the wheel nuts to the specified torque with a torque wrench as soon as possible.

**Wheel nut tightening torque:
80 ft-lb (108 N-m)**

The wheel nuts must be kept tightened to specification at all times. It is recommended that the wheel nuts be tightened to specification at each lubrication interval.

- After adjusting tire pressure to the COLD tire pressure, the display of the tire pressures may show higher pressure than the COLD tire pressure after

the vehicle has been driven more than 1 mile (1.6 km). This is because the tire pressurizes as tire temperature rises. This does not indicate a system malfunction.

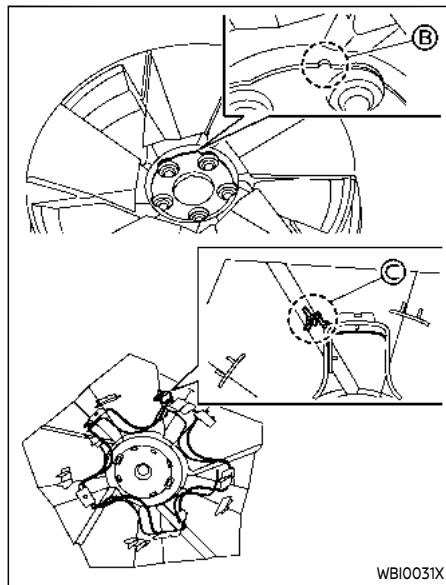

WB10031X

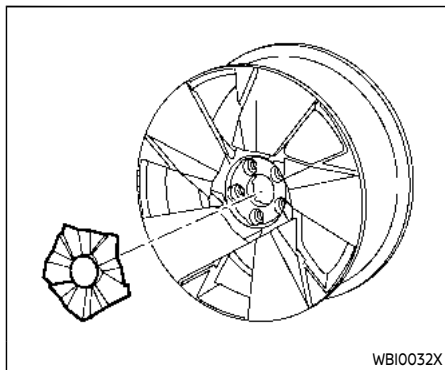

Installing wheel center cover (models with 20 inch wheel):

1. Align the notch **Ⓢ** on the wheel with the anti-rotation pin **Ⓢ** on the cover.
2. Push with the palm of your hand perpendicularly to the cover surface.

Stowing damaged tire and tools



WARNING

Be sure that the tire, jack and tools used are properly stored after use. Such items can become dangerous projectiles in an accident or sudden stop.

1. Securely store the damaged tire, jack and tools used in the storage area.
2. Replace the luggage floor board.
3. Close the liftgate.

JUMP STARTING

To start your EV (Electric Vehicle) system with a booster battery, the instructions and precautions below must be followed.

Jump starting provides power to the 12-volt system to allow the electrical systems to operate. The electrical systems must be operating to allow the Li-ion battery to be charged. Jump starting does not charge the Li-ion battery. The Li-ion battery must be charged before the vehicle can be driven.



WARNING

- Incorrect jump starting can lead to a 12-volt battery explosion. The 12-volt battery explosion may result in severe injury or death. It may also result in damage to the vehicle. Be sure to follow the instructions in this section.
- Explosive hydrogen gas is always present in the vicinity of the 12-volt battery. Keep all sparks and flames away from the 12-volt battery.
- Always wear suitable eye protection and remove rings, bracelets, and any other jewelry whenever working on or near a 12-volt battery.

- Never lean over the 12-volt battery while jump starting.
- Never allow battery fluid to come into contact with eyes, skin, clothes or the vehicle's painted surfaces. Battery fluid is a corrosive sulfuric acid which can cause severe burns. If the fluid comes into contact with anything, immediately flush the contacted area with plenty of water.
- Keep the 12-volt battery out of the reach of children.
- The booster battery must be rated at 12 volts. Use of an incorrectly rated battery will damage your vehicle.
- Never attempt to jump start a frozen battery. It could explode and cause serious injury.
- Your vehicle has an automatic cooling fan. It could come on at any time. Keep hands and other objects away from it.
- Always follow the instructions below. Failure to do so could result in damage to the DC/DC converter and cause personal injury.



CAUTION

- Do not attempt to perform a jump start on the 12-volt battery at the same time that the Li-ion battery is being charged. Doing so may damage the vehicle or charging equipment and could cause an injury.
- ARIYA cannot be used as a booster vehicle because it cannot supply enough power to start a gasoline engine. However, a gasoline engine vehicle can be used to supply power to the 12-volt battery of electric vehicle.

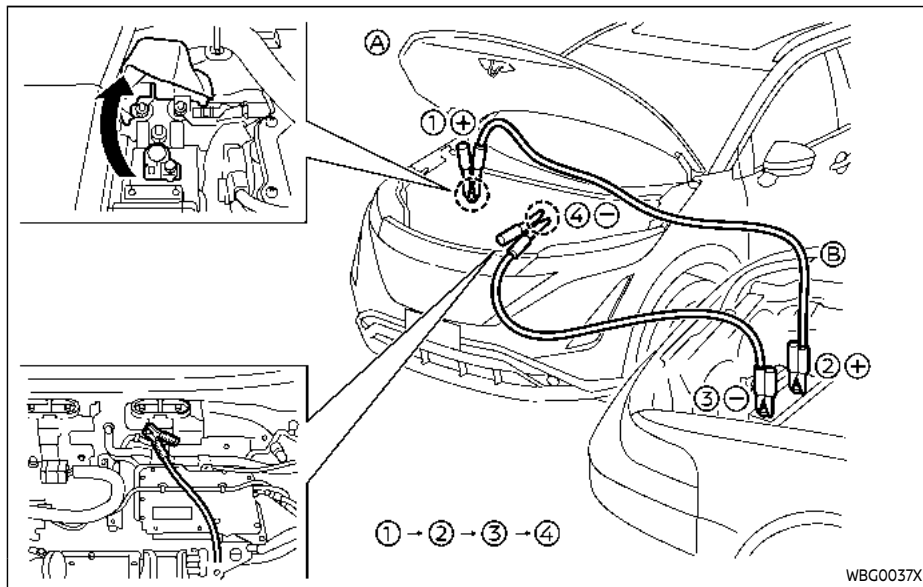

1. If the booster battery is in another vehicle (B), position the two vehicles (A) and (B) to bring their 12-volt batteries into close proximity to each other.
Do not allow the two vehicles to touch.

2. Apply the parking brake.
3. Push the park button to place the vehicle in the P (Park) position.
4. Switch off all unnecessary electrical systems (headlights, heater, air conditioner, etc.).

5. Place the power switch in the OFF position.
6. Remove the vent caps (if so equipped) on the 12-volt battery. Cover the battery with a firmly wrung out moist cloth to reduce the hazard of an explosion.
7. Connect jumper cables in the sequence as illustrated (1 → 2 → 3 → 4).



CAUTION

- If the 12-volt battery is discharged, the power switch cannot be moved from the OFF position. Connect the jumper cables to the booster vehicle (B) before pushing the power switch.
- Always connect positive (+) to positive (+) and negative (-) to body ground (for example, as illustrated, not to the 12-volt battery).
- Make sure the jumper cables do not touch moving parts in the motor compartment and that the cable clamps do not contact any other metal.

8. Start the engine of the booster vehicle ③.
9. While the booster vehicle ③ engine is running, place the power switch in the READY to drive position.



CAUTION

If the system does not start right away, push the power switch to the OFF position and wait 10 seconds before trying again.

10. After starting your EV system, carefully disconnect the negative cable and then the positive cable (④ → ③ → ② → ①) and keep the READY to drive position over 20 minutes to charge the 12-volt battery.
11. Replace the vent caps (if so equipped). Be sure to dispose of the cloth used to cover the vent holes because it may be contaminated with corrosive acid.
12. If necessary, connect the vehicle to a charging station or NISSAN EVSE (Electric Vehicle Supply Equipment) (if so equipped) to charge the Li-ion battery. (See "Charging" (P.CH-1) section.) The vehicle cannot be driven until the Li-ion battery is charged.

NOTE:

If it is not possible to turn the system ON by following this procedure, it is recommended that you contact a NISSAN certified ARIYA dealer immediately.

IF THE LI-ION BATTERY BECOMES COMPLETELY DISCHARGED

If the power limitation indicator light  illuminates, the traction motor output is limited resulting in reduced vehicle speed. Stop the vehicle in a safe location before the Li-ion battery becomes completely discharged and no power is available to drive the vehicle.

If possible, place the power switch in the OFF position while waiting for assistance to prevent discharging the 12-volt battery.

NOTE:

If the Li-ion battery becomes completely discharged:

- The vehicle is automatically placed in the ON position and it will not be possible to switch to the READY to drive position.
- The vehicle is automatically switched to the N (Neutral) position and it will not be possible to drive the vehicle.



WARNING

If the vehicle is in the N (Neutral) position and the Li-ion battery and the 12-volt battery become completely discharged, the vehicle cannot be placed in the P (Park) position. If this occurs, apply the parking brake securely.

PUSH STARTING

To place the vehicle in the READY to drive position so the vehicle can be driven, charge the Li-ion battery until the driving range on the instrument panel changes from “---” to a numeric distance.

NOTE:

- **Some vibration may occur when the vehicle is stopped in case the Li-ion battery becomes completely discharged. This is not a malfunction.**
- **If the Li-ion battery is completely discharged, it is required to charge until the low battery charge warning light (yellow) turns off (white).**

Do not attempt to start the system by pushing the vehicle.



CAUTION

An EV (Electric Vehicle) cannot be push-started or tow-started. Attempting to do so may cause traction motor damage.

TOWING YOUR VEHICLE

When towing your vehicle, local regulations for towing must be followed. Incorrect towing equipment could damage your vehicle. Towing instructions are available from a NISSAN certified ARIYA dealer. Local service operators are familiar with the applicable laws and procedures for towing. To assure proper towing and to prevent accidental damage to your vehicle, NISSAN recommends that you have a service operator tow your vehicle. It is advisable to have the service operator carefully read the following precautions.



WARNING

- **Never ride in a vehicle that is being towed.**
- **Never get under your vehicle after it has been lifted by a tow truck.**



CAUTION

- **When towing, make sure that the axles, steering system and powertrain are in working condition. If any of these conditions apply, dollies or a flatbed tow truck must be used.**

- **Always attach safety chains before towing.**

NOTE:

If the battery is completely drained, the vehicle will not manually shift to other positions. For shifting to other positions, charge the battery or supply power following the jump starting procedure. Push the park button to shift to the P (Park) position before shifting to other positions.

For additional information about towing your vehicle behind a Recreational Vehicle (RV), see "Flat towing" (P.10-22).

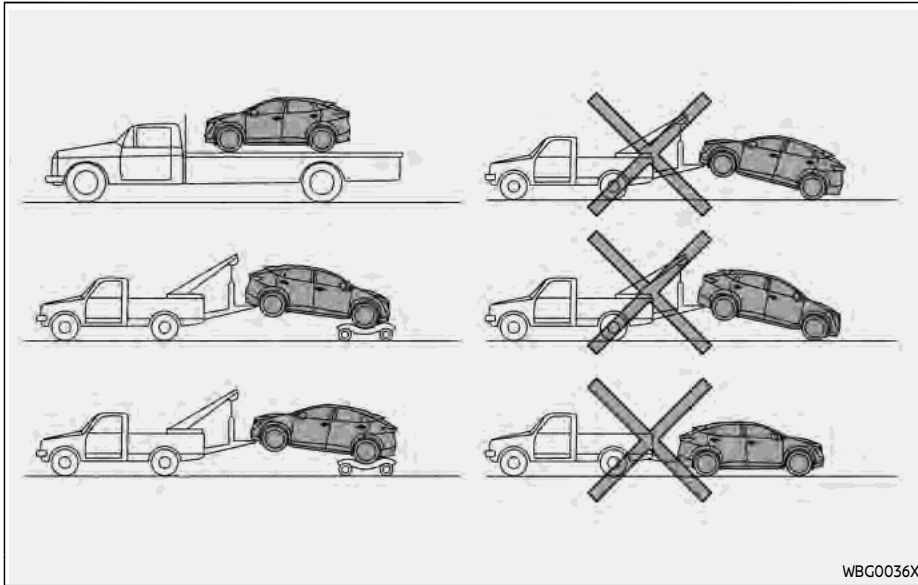

TOWING RECOMMENDED BY NISSAN

All-Wheel Drive (AWD) models
NISSAN recommends that towing dollies be used when towing your vehicle or the vehicle be placed on a flat bed truck as illustrated.



Never tow All-Wheel Drive (AWD) models with any of the wheels on the ground as this may cause serious and expensive damage to the motor.

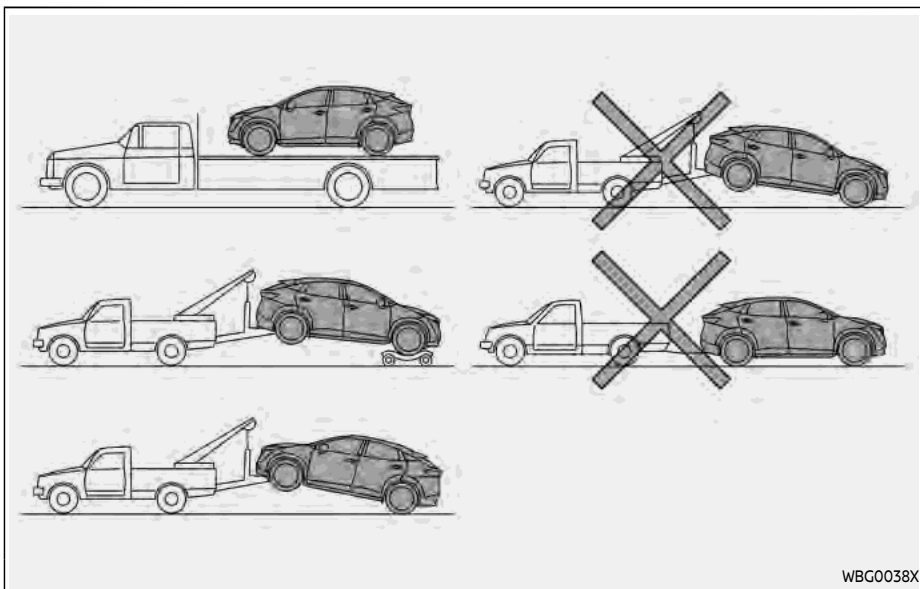

Two-Wheel Drive (2WD) models

NISSAN recommends that your vehicle be towed with the driving (front) wheels off the ground or that the vehicle be placed on a flatbed truck as illustrated.

and expensive damage to the motor.

- When towing this vehicle with the front wheels on towing dollies:
 - Place the power switch in the ON position. Secure the steering wheel in the straight-ahead position with a rope or similar device.
 - Place the shift lever in the N (Neutral) position.
- When towing this vehicle with the rear wheels on the ground (if you do not use towing dollies): Always release the parking brake.

NOTE:

If the electronic parking brake is released, the rear wheels can be grounded while towing. If the electronic parking brake is not released, towing dollies should be used. For additional information, refer to "Parking brake" (P.5-24).

CAUTION

- Never tow with the front wheels on the ground or four wheels on the ground (forward or backward), as this may cause serious

VEHICLE RECOVERY (freeing a stuck vehicle)



WARNING

To avoid vehicle damage, serious personal injury or death when recovering a stuck vehicle:

- Contact a professional towing service to recover the vehicle if you have any questions regarding the recovery procedure.
- Tow chains or cables must be attached only to main structural members of the vehicle.
- Do not use the vehicle tie-downs to tow or free a stuck vehicle.
- Only use devices specifically designed for vehicle recovery and follow the manufacturer's instructions.
- Always pull the recovery device straight out from the front of the vehicle. Never pull at an angle.
- Route recovery devices so they do not touch any part of the vehicle except the attachment point.

If your vehicle is stuck in sand, snow, mud,

etc., use a tow strap or other device designed specifically for vehicle recovery. Always follow the manufacturer's instructions for the recovery device.

Rocking a stuck vehicle



WARNING

- Stand clear of a stuck vehicle.
- Do not spin your tires at high speed. This could cause them to explode and result in serious injury. Parts of your vehicle could also overheat and be damaged.

If your vehicle is stuck in sand, snow, mud, etc., use the following procedure:

1. Turn off the Vehicle Dynamic Control (VDC) system.
2. Make sure the area in front and behind the vehicle is clear of obstructions.
3. Turn the steering wheel right and left to clear an area around the front tires.
4. Slowly rock the vehicle forward and backward.
 - Shift back and forth between R (Reverse) and D (Drive).

- Apply the accelerator as little as possible to maintain the rocking motion.
 - Release the accelerator pedal before shifting between R and D.
 - Do not spin the tires above 35 MPH (55 km/h).
5. If the vehicle cannot be freed after a few tries, contact a professional towing service to remove the vehicle.

MEMO

7 Appearance and care

Cleaning exterior	7-2	Floor mats	7-5
Washing	7-2	Seat belts	7-7
Waxing	7-3	Cleaning the seat tracks	7-7
Removing spots	7-3	EVSE (Electric Vehicle Supply Equipment) (if so equipped)	7-7
Underbody	7-3	Corrosion protection	7-7
Glass	7-3	Most common factors contributing to vehicle corrosion	7-7
Wheels	7-3	Environmental factors influence the rate of corrosion	7-7
Aluminum alloy wheels	7-4	To protect your vehicle from corrosion	7-8
Chrome parts	7-4		
Tire dressing	7-4		
Cleaning interior	7-4		
Air fresheners	7-5		

CLEANING EXTERIOR

In order to maintain the appearance of your vehicle, it is important to take proper care of it.

To protect the paint surfaces, wash your vehicle as soon as you can:

- after a rainfall to prevent possible damage from acid rain
- after driving on coastal roads
- when contaminants such as soot, bird droppings, tree sap, metal particles or bugs get on the paint surface
- when dust or mud builds up on the surface

Whenever possible, store or park your vehicle inside a garage or in a covered area.

When it is necessary to park outside, park in a shady area or protect the vehicle with a body cover.

Be careful not to scratch the paint surface when putting on or removing the body cover.

WASHING

Wash dirt off the vehicle with a wet sponge and plenty of water. Clean the vehicle thoroughly using a mild soap, a special vehicle soap or general purpose dishwashing liquid mixed with clean, lukewarm (never hot) water.



CAUTION

- **Do not concentrate water spray directly on the Sonar sensors on the bumper as this will result in damage to the sensors. Do not use pressure washers capable of spraying water over 1,200 psi (8,274 kPa) to wash your vehicle. Use of high-pressure washers over, 1,200 psi (8,274 kPa) can result in damage to or removal of paint or graphics. Avoid using a high-pressure washer closer than 12 in (30 cm) to the vehicle. Always use a wide-angle nozzle only, keep the nozzle moving and do not concentrate the water spray on any one area.**
- **Do not use car washes that use acid in the detergent. Some car washes, especially brushless ones, use some acid for cleaning. The acid may react with some plastic vehicle components, causing them to crack. This could affect their appearance, and also could cause them not to function properly. Always check with your car wash to confirm that acid is not used.**

- **Do not wash the vehicle with strong household soap, strong chemical detergents, gasoline or solvents.**
- **Do not wash the vehicle in direct sunlight or while the vehicle body is hot, as the surface may become water-spotted.**
- **Avoid using tight-napped or rough cloths, such as washing mitts. Care must be taken when removing caked-on dirt or other foreign substances so the paint surface is not scratched or damaged.**
- **Do not wash the motor compartment. Doing so may damage the electrical parts.**

Rinse the vehicle thoroughly with plenty of clean water.

Inside flanges, seams and folds on the doors, hatches and hood are particularly vulnerable to the effects of road salt. Therefore, these areas must be regularly cleaned. Make sure that the drain holes in the lower edge of the door are open. Spray water under the body and in the wheel wells to loosen the dirt and wash away road salt.

Avoid leaving water spots on the paint

surface by using a damp chamois to dry the vehicle.

WAXING

Regular waxing protects the paint surface and helps retain new vehicle appearance. Polishing is recommended to remove built-up wax residue and to avoid a weathered appearance before reapplying wax.

A NISSAN certified ARIYA dealer can assist you in choosing the proper product.

- Wax your vehicle only after a thorough washing. Follow the instructions supplied with the wax.
- Do not use a wax containing any abrasives, cutting compounds or cleaners that may damage the vehicle finish.

Machine compound or aggressive polishing on a base coat/clear coat paint finish may dull the finish or leave swirl marks.

REMOVING SPOTS

Remove tar and oil spots, industrial dust, insects, and tree sap as quickly as possible from the paint surface to avoid lasting damage or staining. Special cleaning products are available at a NISSAN certified ARIYA dealer or any automotive accessory stores. It is recommended that you visit a NISSAN certified ARIYA dealer for these products.

UNDERBODY



WARNING

Never use high-pressure washers capable of spraying water under the vehicle when the vehicle undercover has been removed. Doing so can damage the Li-ion battery and cause an electrical shock that may result in serious injury or death.

In areas where road salt is used in winter, the underbody must be cleaned regularly. This will prevent dirt and salt from building up and causing the acceleration of corrosion on the underbody and suspension. Before the winter period and again in the spring, the underseal must be checked and, if necessary, re-treated.

GLASS

Use glass cleaner to remove smoke and dust film from the glass surfaces. It is normal for glass to become coated with a film after the vehicle is parked in the hot sun. Glass cleaner and a soft cloth will easily remove this film.



CAUTION

When cleaning the inside of the windows, do not use sharp-edged tools, abrasive cleaners or chlorine-based disinfectant cleaners. They could damage the electrical conductors or rear window defroster elements.

WHEELS

Wash the wheels when washing the vehicle to maintain their appearance.

- Clean the inner side of the wheels when the wheel is changed or the underside of the vehicle is washed.
- Inspect wheel rims regularly for dents or corrosion. Such damage may cause loss of pressure or poor seal at the tire bead.
- NISSAN recommends that the road wheels be waxed to protect against road salt in areas where it is used during winter.



CAUTION

Do not use abrasive cleaners when washing the wheels.

ALUMINUM ALLOY WHEELS

Wash regularly with a sponge dampened in a mild soap solution, especially during winter months in areas where road salt is used. Salt could discolor the wheels if not removed.



CAUTION

Follow the directions below to avoid staining or discoloring the wheels:

- **Do not use a cleaner that uses strong acid or alkali contents to clean the wheels.**
- **Do not apply wheel cleaners to the wheels when they are hot. The wheel temperature should be the same as ambient temperature.**
- **Rinse the wheel to completely remove the cleaner within 15 minutes after the cleaner is applied.**

CHROME PARTS

Clean chrome parts regularly with a non-abrasive chrome polish to maintain the finish.

TIRE DRESSING

NISSAN does not recommend the use of tire dressings. Tire manufacturers apply a coating to the tires to help reduce discoloration of the rubber. If a tire dressing is applied to the tires, it may react with the coating and form a compound. This compound may come off the tire while driving and stain the vehicle paint.

If you choose to use a tire dressing, take the following precautions:

- Use a water-based tire dressing. The coating on the tire dissolves more easily with an oil-based tire dressing.
- Apply a light coat of tire dressing to help prevent it from entering the tire tread/grooves (where it would be difficult to remove).
- Wipe off excess tire dressing using a dry towel. Make sure the tire dressing is completely removed from the tire tread/grooves.
- Allow the tire dressing to dry as recommended by tire dressing manufacturer.

CLEANING INTERIOR

Occasionally remove loose dust from the interior trim, plastic parts and seats using a vacuum cleaner or soft bristled brush. Wipe the vinyl and leather surfaces with a clean, soft cloth dampened in mild soap solution, then wipe clean with a dry soft cloth.

Regular care and cleaning is required in order to maintain the appearance of the leather (if so equipped).

Before using any fabric protector, read the manufacturer's recommendations. Some fabric protectors contain chemicals that may stain or bleach the seat material.

Use a soft cloth dampened only with water, to clean the meter and gauge lens.



WARNING

Do not use water or acidic cleaners (hot steam cleaners) on the seat. This can damage the seat or occupant classification sensors. This can also affect the operation of the air bag system and result in serious personal injury.



CAUTION

- Never use benzine, thinner, or any similar material.
- For cleaning, use a soft cloth, dampened with water. Never use a rough cloth, alcohol, benzine, thinner or any kind of solvent or paper towel with a chemical cleaning agent. They will scratch or cause discoloration to the lens.
- Do not spray any liquid such as water on the meter lens. Spraying liquid may cause the system to malfunction.
- Small dirt particles can be abrasive and damaging to the leather surfaces and should be removed promptly. Do not use saddle soap, car waxes, polishes, oils, cleaning fluids, solvents, detergents or ammonia-based cleaners as they may damage the leather's natural finish.
- Never use fabric protectors unless recommended by the manufacturer.
- Do not use glass or plastic cleaner on meter or gauge lens covers. It may damage the lens cover.

- Do not spill on or make contact with interior surfaces while handling air fresheners, aroma agents, cosmetics, sunscreen, etc. They may cause permanent discoloration, stain, crack, paint peeling, etc. depending on the ingredients. If they contact the interior surface, wipe them off immediately using a soft cloth.
- Do not use the chlorine-based cleaning liquid such as chlorine dioxide and hypochlorous acid, which may cause the paint peeling, corrosion, etc. If it is unavoidable to clean or sterilize interior surfaces, use less than 75% ethanol. Wipe the interior parts with a dry cloth dampened with ethanol. Wipe off ethanol completely. If you leave it uncleaned, it may cause paint peeling, discoloration, etc. Since ethanol is flammable, be careful of fire.

AIR FRESHENERS

Most air fresheners use a solvent that could affect the vehicle interior. If you use an air freshener, take the following precautions:

- Hanging-type air fresheners can cause permanent discoloration when they contact vehicle interior surfaces. Place the air freshener in a location that allows it to hang free and not contact an interior surface.
- Liquid-type air fresheners typically clip on the vents. These products can cause immediate damage and discoloration when spilled on interior surfaces.

Carefully read and follow the manufacturer's instructions before using air fresheners.

FLOOR MATS



WARNING

To avoid potential pedal interference that may result in a collision, injury or death:

- NEVER place a floor mat on top of another floor mat in the driver front position or install them upside down or backwards.

- It is recommended that you use only genuine NISSAN floor mats specifically designed for use in your vehicle model and model year.
- Properly position the mats in the floorwell using the floor mat positioning hooks. See "Floor mat installation" (P.7-6).
- Make sure the floor mat does not interfere with pedal operation.
- Periodically check the floor mats to make sure they are properly installed.
- After cleaning the vehicle interior, check the floor mats to make sure they are properly installed.

The use of genuine NISSAN floor mats can extend the life of your vehicle carpet and make it easier to clean the interior. Mats should be maintained with regular cleaning and replaced if they become excessively worn.

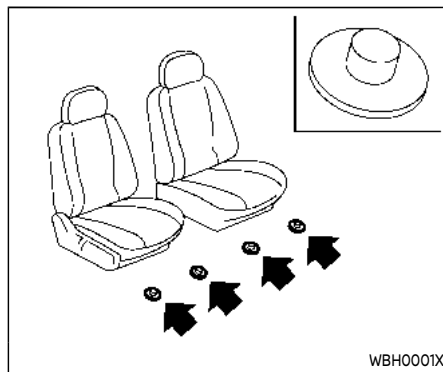

Floor mat installation

Your vehicle is equipped with floor mat positioning hook(s). The number and shape of the floor mat positioning hook (s) for each seating position varies depending on the vehicle.

When installing genuine NISSAN floor mats, follow the installation instructions provided with the floor mat and the following:

1. Position the floor mat in the floorwell so that the floor mat grommet holes are aligned with the hook(s).
2. Push the grommet holes into the hook (s) and secure them. Ensure that the

floor mat is properly positioned.

3. Make sure the floor mat does not interfere with pedal operation. With the power switch in the OFF position and the shift position in the P (Park) position, fully apply and release all pedals. The floor mat must not interfere with pedal operation or prevent the pedal from returning to its normal position. It is recommended you see a NISSAN certified ARIYA dealer for details about installing the floor mats in your vehicle.

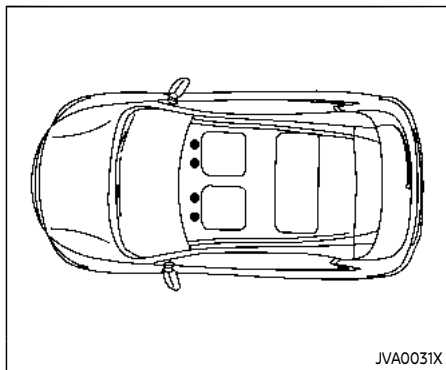

Positioning hook(s)

The illustration shows the location of the floor mat positioning hook(s).

SEAT BELTS

The seat belts can be cleaned by wiping them with a sponge dampened in a mild soap solution. Allow the belts to dry completely in the shade before using them.

See "Seat belts" (P.1-14).



WARNING

Do not allow wet seat belts to roll up in the retractor. NEVER use bleach,

dye, or chemical solvents to clean the seat belts, since these materials may severely weaken the seat belt webbing.

CLEANING THE SEAT TRACKS



CAUTION

Periodically clean the seat tracks to prevent reduction of ability to move the seats.

Clean periodically with a high-powered vacuum cleaner. Dirt and debris may reduce the ability to adjust the seat. A wet cleansing agent may be used if necessary.

EVSE (Electric Vehicle Supply Equipment) (if so equipped)

The Electric Vehicle Supply Equipment (EVSE) can be cleaned by wiping gently with a soft cloth dampened in a 3% mild soap solution. Wipe and rinse the soap solution off with a cloth dampened with water and allow the EVSE to dry in a shady and well-ventilated place.

CORROSION PROTECTION

MOST COMMON FACTORS CONTRIBUTING TO VEHICLE CORROSION

- The accumulation of moisture-retaining dirt and debris in body panel sections, cavities, and other areas.
- Damage to paint and other protective coatings caused by gravel and stone chips or minor traffic accidents.

ENVIRONMENTAL FACTORS INFLUENCE THE RATE OF CORROSION

Moisture

Accumulation of sand, dirt and water on the vehicle body underside can accelerate corrosion. Wet floor coverings will not dry completely inside the vehicle, and should be removed for drying to avoid floor panel corrosion.

Relative humidity

Corrosion will be accelerated in areas of high relative humidity, especially those areas where the temperatures stay above freezing where atmospheric pollution exists, or where road salt is used.

Temperature

A temperature increase will accelerate the rate of corrosion to those parts which are not well ventilated.

Air pollution

Industrial pollution, the presence of salt in the air in coastal areas, or heavy road salt use will accelerate the corrosion process. Road salt will also accelerate the disintegration of paint surfaces.

TO PROTECT YOUR VEHICLE FROM CORROSION

- Wash and wax your vehicle often to keep the vehicle clean.
- Always check for minor damage to the paint and repair it as soon as possible.
- Keep drain holes at the bottom of the doors open to avoid water accumulation.
- Check the underbody for accumulation of sand, dirt or salt. If present, wash with water as soon as possible.



CAUTION

- **NEVER** remove dirt, sand or other debris from the passenger compartment by washing it out with a hose. Remove dirt with a vacuum

cleaner.

- **Never allow water or other liquids to come in contact with electronic components inside the vehicle as this may damage them.**

Chemicals used for road surface deicing are extremely corrosive. They accelerate corrosion and deterioration of underbody components such as the brake lines, brake cables, floor pan and fenders.

In winter, the underbody must be cleaned periodically.

For additional protection against rust and corrosion, which may be required in some areas, it is recommended you consult a NISSAN certified ARIYA dealer.

8 Do-it-yourself

Maintenance precautions	8-2	12-volt battery	8-11
Motor compartment check locations	8-4	12-volt battery	8-12
Cooling system	8-4	Jump starting	8-13
Checking coolant level	8-6	Intelligent Key battery replacement	8-13
Changing coolant	8-6	Fuses	8-15
Reduction gear oil	8-6	Lights	8-16
Brake fluid	8-7	Headlights	8-17
Windshield wiper blades	8-8	Exterior and interior lights	8-17
Cleaning	8-8	Wheels and tires	8-18
Replacing	8-8	Tire pressure	8-18
Rear window wiper blade	8-9	Tire labeling	8-22
Brakes	8-9	Types of tires	8-25
Brake pad wear warning	8-9	Tire chains	8-26
Window washer fluid	8-10	Changing wheels and tires	8-27
		Emergency tire puncture repair kit	8-30

MAINTENANCE PRECAUTIONS

When performing any inspection or maintenance work on your vehicle, always take care to prevent serious accidental injury to yourself or damage to the vehicle. The following are general precautions that should be closely observed.



WARNING

- The EV (Electric Vehicle) system uses high voltage up to approximately DC 400 volt. The system can be hot during and after starting and when the vehicle is shut off. Be careful of both the high voltage and the high temperature. Obey the labels that are attached to the vehicle.
- Never disassemble, remove or replace high-voltage parts and cables as well as their connectors. High-voltage cables are colored orange.
- Disassembling, removing or replacing those parts or cables can cause severe burns or electric shock that may result in serious injury or death. The vehicle high voltage system has no user serviceable parts. It is recommended that you take your vehicle to the

NISSAN certified ARIYA dealer for any necessary maintenance.

- Park the vehicle on a level surface, apply the parking brake securely and chock the wheels to prevent the vehicle from moving. Push the park button on the shift lever or place the vehicle into the N (Neutral) position.
- If you must work with the EV (Electric vehicle) system is turned on, keep hands, clothing, hair and tools away from moving fans and any other moving parts.
- Make sure that the power switch is in the OFF position and the charge connector has been disconnected when performing any maintenance work.
- It is advisable to secure or remove any loose clothing and remove any jewelry, such as rings, watches, etc. before working on your vehicle.
- Always wear eye protection whenever you work on your vehicle.
- Never get under the vehicle while it is supported by a jack.

- Keep smoking materials, flames and sparks away from the 12-volt battery.



CAUTION

- Do not work under the hood while the motor compartment is hot. Push the power switch in the OFF position and wait until it cools down.
- Avoid direct contact with used coolant. Improperly disposed coolant and/or other vehicle fluids can damage the environment. Always conform to local regulations for the disposal of vehicle fluids.
- Never connect or disconnect the battery or any transistorized component while the power switch is in the ON position.
- Your vehicle is equipped with an automatic cooling fan. It may come on at any time without warning, even if the power switch is not in the ON or READY to drive position. To avoid injury, always disconnect the negative 12-volt battery cable before working

near the fan.

- When “Charging status indicator light” (P.CH-38) is lit or blinking, do not perform a maintenance work. There is a risk of electric shock because the high voltage system is operating.
- If the charging status indicator light does not turn off, take the following actions.
 - Push and hold the power switch for longer than 2 seconds and check that the charging status indicator light is off.
 - Open the driver’s door, get out of the vehicle, close the door and wait for longer than 5 minutes.

If the charging status indicator light flashes every 1 second, the 12-volt battery charging is in operation.
- Do not perform any maintenance work in the following situations.
 - When charging the Li-ion battery with the EVSE (if so equipped) or a charge cable.
 - When 12-volt battery is charging. See “Charging the 12-

volt battery” (P.EV-4) and “Charging status indicator light” (P.CH-38).

- When remote climate control or Climate Ctrl. Timer is working. See “Climate Ctrl. Timer” (P.4-35).
- When the software is updating.

This “8. Maintenance and do-it-yourself” section gives instructions regarding only those items that are relatively easy for an owner to perform.

A genuine NISSAN Service Manual is also available. (See “Owner’s manual/service manual order information” (P.10-27).)

You should be aware that incomplete or improper servicing may result in operating difficulties and could affect your warranty coverage. **If in doubt about any servicing, we recommend that it be done by a NISSAN certified ARIYA dealer.**

MOTOR COMPARTMENT CHECK LOCATIONS

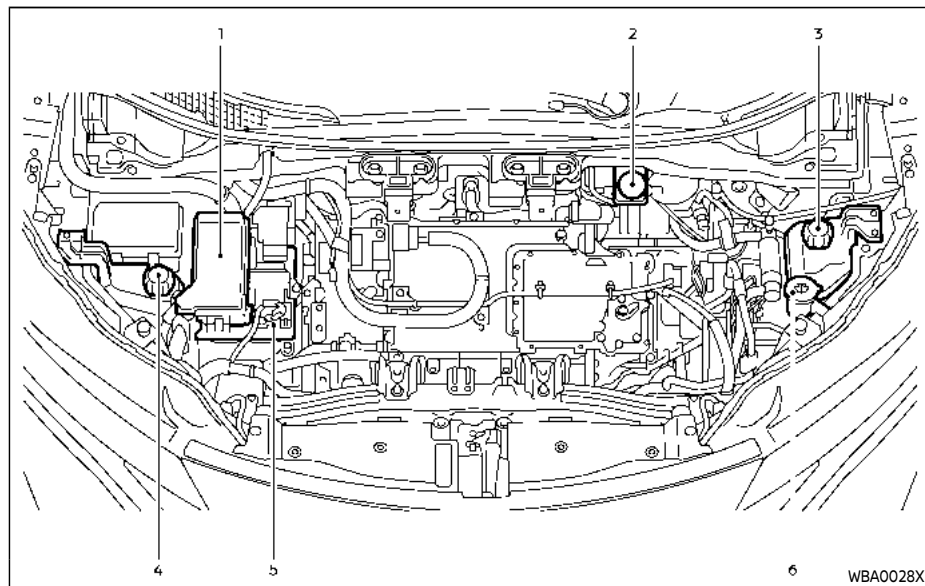

1. Fuse/fusible link holders
2. Brake fluid reservoir*1
3. Coolant reservoir (for electric powertrain)
4. Coolant reservoir (for Li-ion battery)
5. 12-volt battery*2
6. Window washer fluid reservoir

8-4 Do-it-yourself

COOLING SYSTEM

The cooling system is filled at the factory with a pre-diluted mixture of 50% Genuine NISSAN Long Life Antifreeze/Coolant (blue) and 50% water to provide year-round antifreeze and coolant protection. The antifreeze solution contains rust and corrosion inhibitors. Additional cooling system additives are not necessary.

WARNING

- Never remove the coolant reservoir cap when the motor compartment is hot. Wait until the motor compartment cools down.
- Coolant is poisonous and should be stored carefully in marked containers out of the reach of children.

CAUTION

- Never use any additives in the coolant such as radiator sealer in the cooling system. This may cause damage to electrical equipment such as the motor and inverter.

- When adding or replacing coolant, be sure to use only a Genuine NISSAN Long Life Antifreeze/Coolant (blue) or equivalent. Genuine NISSAN Long Life Antifreeze/Coolant (blue) is prediluted to provide antifreeze protection to -34°F (-37°C). If additional freeze protection is needed due to the weather conditions where you operate your vehicle, add Genuine NISSAN Long Life Antifreeze/Coolant (blue) concentrate following the directions on the container. If an equivalent coolant other than Genuine NISSAN Long Life Antifreeze/Coolant (blue) is used, follow the coolant manufacturer's instructions to maintain minimum antifreeze protection to -34°F (-37°C). The use of other types of coolant solutions other than Genuine NISSAN Long Life Antifreeze/Coolant (blue) or equivalent may damage the cooling system.
- The life expectancy of the factory-fill coolant is 125,000 miles (200,000 km) or 15 years. Mixing any other type of coolant other than Genuine NISSAN Long Life Antifreeze/Coolant (blue) (or

equivalent coolant), including Genuine NISSAN Long Life Antifreeze/Coolant (green), or the use of non-distilled water may reduce the life expectancy of the factory-filled coolant. For additional information, refer to the "Maintenance and schedules" section of this manual.

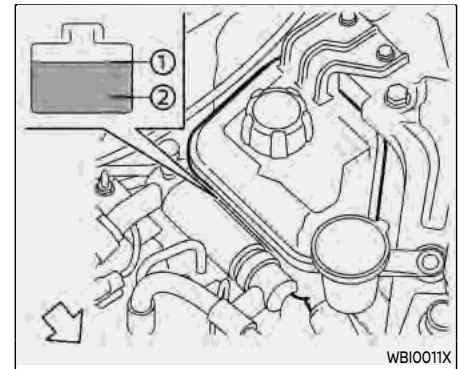
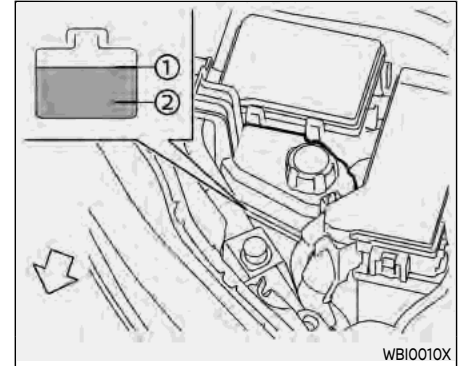

CHECKING COOLANT LEVEL

Check the coolant level **in the reservoir when the high voltage parts are cold**. If the coolant level is below the MIN level ②, open the reservoir cap and add coolant up to the MAX level ①. If the reservoir is empty, check the coolant level in the coolant reservoir **when the high voltage parts are cold**. If there is insufficient coolant in the coolant reservoir, fill the coolant reservoir with coolant up to the reservoir cap opening and also add it to the reservoir up to the MAX level ①.

Tighten the cap securely after adding coolant.

For additional information on the location of the coolant reservoir, see "Motor compartment check locations" (P.8-4).

If the cooling system frequently requires coolant, it is recommended that you visit a NISSAN certified ARIYA dealer.

CHANGING COOLANT

It is recommended that major cooling system repairs should be performed by a NISSAN certified ARIYA dealer. The service procedures can be found in the appropriate NISSAN Service Manual.

Improper servicing can result in reduced heater performance.



WARNING

- To avoid the danger of being scalded, never change the coolant when the motor compartment is hot.
- Never remove the coolant reservoir cap when the motor compartment is hot. Serious burns could be caused by high-pressure fluid escaping from the radiator.
- Avoid direct skin contact with used coolant. If skin contact is made, wash thoroughly with soap or hand cleaner as soon as possible.
- Keep coolant out of reach of children and pets.

Coolant must be disposed of properly. Check your local regulations.

REDUCTION GEAR OIL

When checking or replacement is required, it is recommended that you visit a NISSAN certified ARIYA dealer for this service.



CAUTION

- Use only Genuine NISSAN Gear Oil NFX 75W. Do not mix with other oil.
- Using reduction gear oil other than Genuine NISSAN Gear Oil NFX 75W will cause deterioration in drivability and reduction gear durability, and may damage the reduction gear, which is not covered by the NISSAN's New Vehicle Limited Warranty.

BRAKE FLUID

For additional brake fluid information, see "Recommended fluids/lubricants and capacities" (P.10-2).

WARNING

- Use only new fluid from a sealed container. Old, inferior or contaminated fluid may damage the brake system. The use of improper fluids can damage the brake system, and affect the vehicle's stopping ability.
- Clean the filler cap before removing.
- Brake fluid is poisonous and should be stored carefully in marked containers out of the reach of children.

CAUTION

Do not spill the fluid on any painted surfaces. This will damage the paint. If fluid is spilled, immediately wash the surface with water.

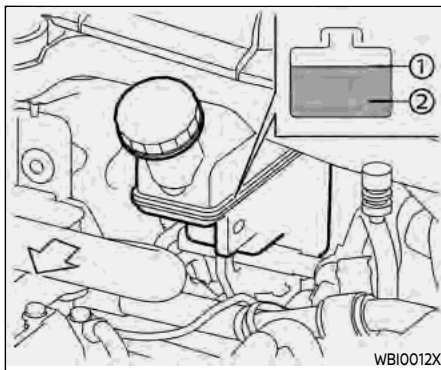

Check the fluid level in the reservoir. If the fluid is below the MIN line ② or the brake warning light illuminates, add Genuine NISSAN Super Heavy Duty Brake Fluid or equivalent **DOT 3** fluid up to the MAX line ①. If fluid must be added frequently, the system should be checked. It is recommended that you visit a NISSAN certified ARIYA dealer for this service.

WINDSHIELD WIPER BLADES

CLEANING

If your windshield is not clear after using the windshield washer or if a wiper blade chatters when running, wax or other material may be on the blade or windshield.

Clean the outside of the windshield with a washer solution or a mild detergent. Your windshield is clean if beads do not form when rinsing with clear water.

Clean each blade by wiping it with a cloth soaked in a washer solution or a mild detergent. Then rinse the blade with clear water. If your windshield is still not clear after cleaning the blades and using the wiper, replace the blades.



CAUTION

Worn windshield wiper blades can damage the windshield and impair driver vision.

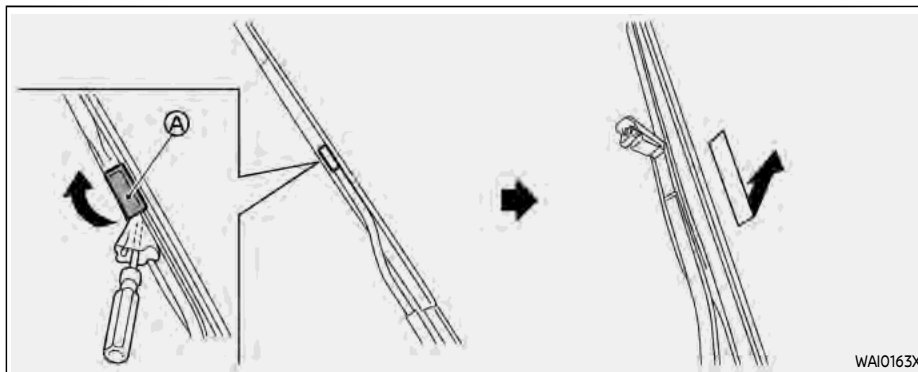

REPLACING

Replace the wiper blades if they are worn.

1. Lift the wiper arm away from the windshield.
2. Open Ⓐ, using a suitable tool, and then move the wiper blade down as shown to remove.
3. Insert the new wiper blade onto the wiper arm until a click sounds.
4. Close Ⓐ.



CAUTION

- **After wiper blade replacement, return the wiper arm to its original position; otherwise it may be damaged when the hood is opened.**
- **Make sure the wiper blades contact the glass; otherwise the arm may be damaged from wind pressure.**

REAR WINDOW WIPER BLADE

It is recommended you contact a NISSAN certified ARIYA dealer if checking or replacement is required.

BRAKES

If the brakes do not operate properly, have the brakes checked. It is recommended that you visit a NISSAN certified ARIYA dealer.



WARNING

Do not adjust the height of the brake pedal. Doing so could alter the effectiveness of the brakes, which could result in a serious accident and personal injury. If adjustment is required, it is recommended that you contact a NISSAN certified ARIYA dealer.

noise during light to moderate stops is normal and does not affect the function or performance of the brake system.

Proper brake inspection intervals should be followed. For additional information, see a separate maintenance booklet.

BRAKE PAD WEAR WARNING

The disc brake pads have audible wear warnings. When a brake pad requires replacement, it will make a high pitched scraping sound when the vehicle is in motion. This scraping sound will first occur only when the brake pedal is depressed. After more wear of the brake pad, the sound will always be heard even if the brake pedal is not depressed. Have the brakes checked as soon as possible if the wear warning sound is heard.

Under some driving or climate conditions, occasional brake squeak, squeal or other noise may be heard. Occasional brake

WINDOW WASHER FLUID

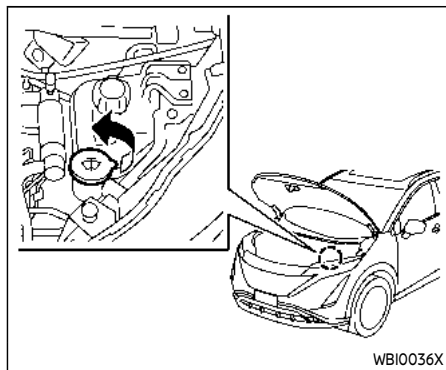

Type A (if so equipped)

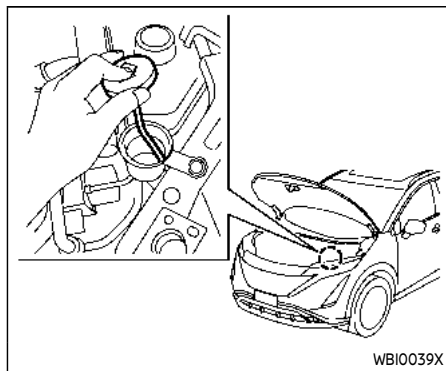

Type B (if so equipped)

WARNING

Anti-freeze is poisonous and should be stored carefully in marked containers out of the reach of children.

Type A: Check the fluid level in the window washer reservoir. If the fluid level is low, add window washer fluid.

Type B: To check the fluid level, use your finger to plug the center hole of the cap/tube assembly, then remove it from the reservoir. If there is no fluid in the tube, add fluid.

Add a washer solvent to the washer for better cleaning. In the winter season, add a windshield washer antifreeze. Follow the manufacturer's instructions for the mixture ratio.

Fill the window washer fluid reservoir periodically.

Add fluid when the low washer fluid warning appears (if so equipped).

Refill the reservoir more frequently when driving conditions require an increased amount of window washer fluid.

Recommended fluid:







Genuine NISSAN Windshield Washer Concentrate Cleaner & Antifreeze or equivalent

lent

CAUTION

- Do not substitute anti-freeze coolant for window washer solution. This may result in damage to the paint.
- Do not fill the window washer reservoir tank with washer fluid concentrates at full strength. Some methyl alcohol based washer fluid concentrates may permanently stain the grille if spilled while filling the window washer reservoir tank.
- Pre-mix washer fluid concentrates with water to the manufacturer's recommended levels before pouring the fluid into the window washer reservoir tank. Do not use the window washer reservoir tank to mix the washer fluid concentrate and water.

12-VOLT BATTERY

Caution symbols for battery		 WARNING
①	 No smoking, No exposed flames, No sparks	Do not expose the battery to electrical sparks, flames or smoking. Hydrogen gas generated by the battery is explosive. Explosive gases can cause blindness or injury.
②	 Shield eyes	Handle the battery cautiously. Always wear eye protection glasses to protect against explosion or battery acid.
③	 Keep away from children	Never allow children to handle battery. Keep the battery out of the reach of children.
④	 Battery acid	Do not allow battery fluid to contact your skin, eyes, fabrics, or painted surfaces. Sulfuric acid can cause blindness or severe burns. After touching a battery or battery cap, do not touch or rub your eyes. Thoroughly wash your hands. If the acid contacts your eyes, skin or clothing, immediately flush with water for at least 15 minutes and seek medical attention. Battery fluid is acidic. If the battery fluid gets into your eyes or onto your skin, it could cause loss of your eyesight or burns.
⑤	 Note operating instructions	Before handling the battery, read this instruction carefully to ensure correct and safe handling.
⑥	 Explosive gas	Hydrogen gas generated by battery fluid is explosive. Explosive gases can cause blindness or injury.

WAI0270X

- If the 12-volt battery is labeled "do not open" it is maintenance free and 12-volt battery fluid should not be checked. It is recommended that you visit a NISSAN certified ARIYA dealer or a qualified specialist workshop to confirm the 12-volt battery's performance.
- Keep the 12-volt battery surface clean and dry. Clean the 12-volt battery with a solution of baking soda and water.
- Make certain the terminal connections are clean and securely tightened.
- If the vehicle is not to be used for 30 days or longer, disconnect the negative ⊖ 12-volt battery terminal cable to prevent discharging it.

NOTE:

Care should be taken to avoid situations that can lead to potential 12-volt battery discharge and potential no-start conditions such as:

1. Installation or extended use of electronic accessories that consume 12-volt battery power when the EV system is not running (Phone chargers, GNSS, DVD players, etc.).
2. Vehicle is not driven regularly and/or only driven short distances.

In these cases, the 12-volt battery may need to be charged to maintain 12-volt battery health.

**WARNING**

- Do not operate the vehicle if the fluid in the 12-volt battery is low. Low 12-volt battery fluid can cause a higher load on the 12-volt battery which can generate heat, reduce 12-volt battery life, and in some cases lead to an explosion.
- Do not expose the 12-volt battery to flames or electrical sparks. Hydrogen gas generated by the 12-volt battery is explosive. Do not allow 12-volt battery fluid to contact your skin, eyes, fabrics or

Painted surfaces. After touching a 12-volt battery or 12-volt battery cap, do not touch or rub your eyes. Thoroughly wash your hands. If the acid contacts your eyes, skin or clothing, immediately flush with water for at least 15 minutes and seek medical attention.

- When working on or near a 12-volt battery, always wear suitable eye protection and remove all jewelry.
- 12-volt battery posts, terminals and related accessories contain lead and lead compounds. Wash hands after handling.
- Keep the 12-volt battery out of the reach of children.
- Do not tip the 12-volt battery.

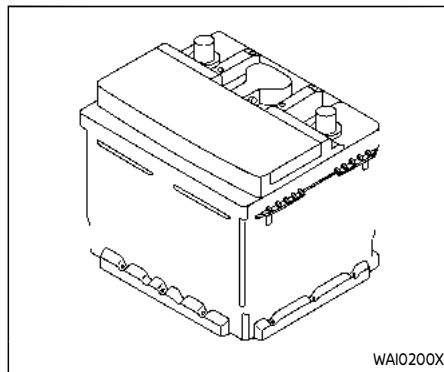

Example

NOTE:

Do not try to open the top of the 12-volt battery.

This 12-volt battery is not equipped with removable vent caps.

12-VOLT BATTERY

For a maintenance free battery, it is not required to check the fluid level. However, NISSAN recommends to check it periodically at a NISSAN certified ARIYA dealer.

NOTE:

For replacing the 12-volt battery, it is recommended that you visit a NISSAN certified ARIYA dealer.

INTELLIGENT KEY BATTERY REPLACEMENT

JUMP STARTING

Jump starting provides power to the 12 volt system to allow the electrical systems to operate. The electrical systems must be operating to allow the Li-ion battery to be charged. Jump starting does not charge the Li-ion battery. The Li-ion battery must be charged before the vehicle can be driven.

If jump starting is necessary, see "Jump starting" (P.6-15). If the power switch does not switch to READY to drive position by jump starting, the 12-volt battery may have to be replaced. It is recommended that you contact a NISSAN certified ARIYA dealer.



CAUTION

- **Be careful not to allow children to swallow the battery and removed parts.**
- **An improperly disposed battery can harm the environment. Always confirm local regulations for battery disposal.**
- **When changing batteries, do not let dust or oil get on the components.**
- **There is danger of explosion if the lithium battery is incorrectly replaced. Replace only with the same or equivalent type.**

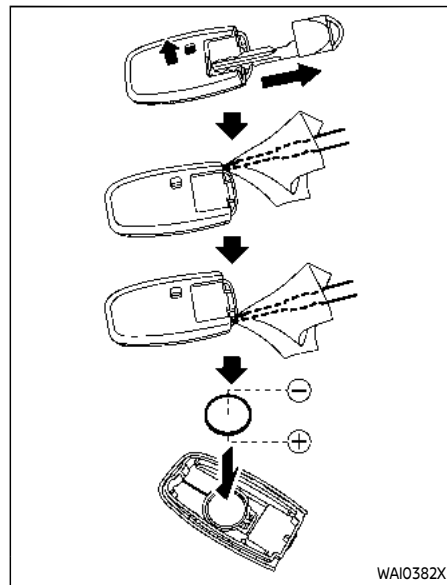

Replace the battery in the Intelligent Key as follows:

1. Remove the mechanical key from the Intelligent Key.
2. Insert a small screwdriver into the slit (on the right and left sides) and twist it to separate the upper part from the

lower part. Use a cloth to protect the casing.

3. Replace the battery with a new one.

Recommended battery:

CR2032 or equivalent

- Do not touch the internal circuit and electric terminals as doing so could cause a malfunction.
- Hold the battery by the edges. Holding the battery across the contact points will seriously deplete the storage capacity.
- Make sure that the ⊕ side faces the bottom of the case.

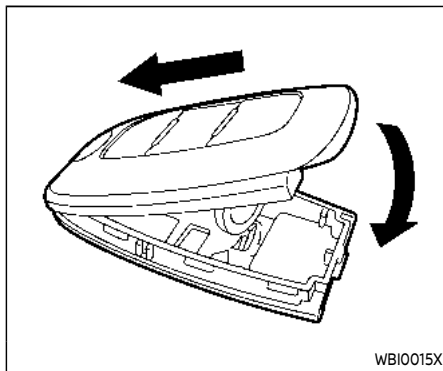

4. Align the tips of the upper and lower parts, and then push them together until it is securely closed.
5. Operate the buttons to check its operation.

If you need any assistance for replacement, it is recommended you visit a NISSAN certified ARIYA dealer for this service.

FCC Notice:

For USA:

FCC ID : KR5TXPZ1

FCC ID : KR5HFM401

FCC ID : KR5HFM403

This device complies with Part 15 of the

FCC Rules. Operation is subject to the following two conditions: (1) This device may not cause harmful interference, and (2) this device must accept any interference received, including interference that may cause undesired operation.

Note: Changes or modifications not expressly approved by the party responsible for compliance could void the user's authority to operate the equipment.

For Canada:

IC ID : 7812D-TXPZ1

IC ID : 7812D-HFM401

IC ID : 7812D-HDM403

This device contains licence-exempt transmitter(s)/receiver(s) that comply with Innovation, Science and Economic Development Canada's licence-exempt RSS(s). Operation is subject to the following two conditions: (1) This device may not cause interference. (2) This device must accept any interference, including interference that may cause undesired operation of the device.

FUSES

Do not open the fuse box.

If you have noticed an electrical equipment malfunction, it is recommended that you consult a NISSAN certified ARIYA dealer.

LIGHTS

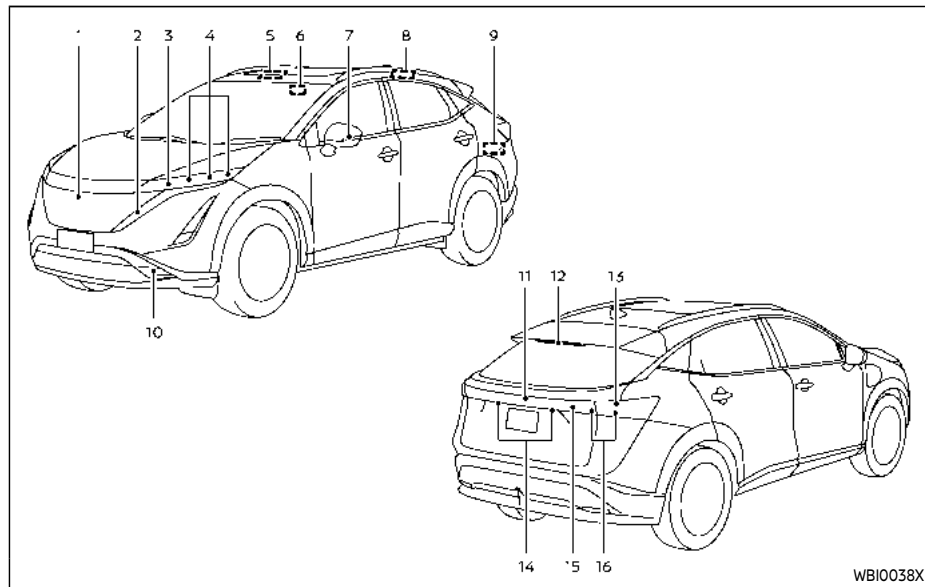

- 14. License plate light
- 15. Back-up light
- 16. Rear turn signal light

- 1. Emblem light
- 2. Front parking light/Daytime running light/Front turn signal light
- 3. Headlight (high-beam)
- 4. Headlight (low-beam)
- 5. Map light
- 6. Vanity mirror light

- 7. Side turn signal light (if so equipped)
- 8. Rear personal light
- 9. Cargo light
- 10. Front fog light (if so equipped)
- 11. Tail light
- 12. High-mounted stop light
- 13. Stop light/Tail light

HEADLIGHTS

Fog may temporarily form inside the lens of the exterior lights in the rain or in a car wash. A temperature difference between the inside and the outside of the lens causes the fog. This is not a malfunction. If large drops of water collect inside the lens, it is recommended you visit a NISSAN certified ARIYA dealer for servicing.

Replacing

If LED headlight replacement is required, it is recommended that you visit a NISSAN certified ARIYA dealer for this service.

EXTERIOR AND INTERIOR LIGHTS

Item	Wattage (W)
Headlight high/low beams*	LED
Front turn signal light*	LED
Front parking light*	LED
Front fog light (if so equipped) *	LED
Side turn signal light (if so equipped)*	LED
Emblem light*	LED
Daytime running light*	LED
Rear combination light*	
Turn signal light	LED
Stop/tail light	LED
Tail light	LED
Back-up light	LED
License plate light*	LED
Map light*	LED
Rear personal light*	LED
Vanity mirror light*	LED
High-mounted stop light*	LED
Cargo light	LED

*: It is recommended you visit a NISSAN certified ARIYA dealer for replacement.

Replacement procedures

It is recommended that you visit a NISSAN certified ARIYA dealer if replacement is required.

WHEELS AND TIRES

If you have a flat tire, see “Flat tire” (P.6-3).

TIRE PRESSURE

Tire Pressure Monitoring System (TPMS)



WARNING

Radio waves could adversely affect electric medical equipment. Those who use a pacemaker should contact the electric medical equipment manufacturer for the possible influences before use.

This vehicle is equipped with the Tire Pressure Monitoring System (TPMS). It monitors tire pressure of all tires. When the low tire pressure warning light is lit, and the “Tire Pressure Low - Add Air” warning message is displayed in the vehicle information display, one or more of your tires is significantly under-inflated.

The TPMS will activate only when the vehicle is driven at speeds above 16 MPH (25 km/h). Also, this system may not detect a sudden drop in tire pressure (for example a flat tire while driving).

For more details, see “Low tire pressure warning light” (P.2-17), “Tire Pressure Mon-

8-18 **Do-it-yourself**

itoring System (TPMS)” (P.5-5) and “Tire Pressure Monitoring System (TPMS)” (P.6-3).

Tire inflation pressure

Check the pressure of the tires often and always prior to long distance trips. The recommended tire pressure specifications are shown on the Tire and Loading Information label under the “Cold Tire Pressure” heading. The Tire and Loading Information label is affixed to the driver side center pillar. Tire pressures should be checked regularly because:

- Most tires naturally lose air over time.
- Tires can lose air suddenly when driven over potholes or other objects or if the vehicle strikes a curb while parking.

The tire pressures should be checked when the tires are cold. The tires are considered COLD after the vehicle has been parked for 3 or more hours, or driven less than 1 mile (1.6 km) at moderate speeds.

TPMS with Easy Fill Tire Alert provides visual and audible signals outside the vehicle for inflating the tires to the recommended COLD tire pressure. (See “TPMS with Easy Fill Tire Alert” (P.5-8).)

Incorrect tire pressure, including under inflation, may adversely affect tire life and vehicle handling.



WARNING

- Improperly inflated tires can fail suddenly and cause an accident.
- The Gross Vehicle Weight Rating (GVWR) is located on the F.M.V.S.S./C.M.V.S.S. certification label. The vehicle weight capacity is indicated on the Tire and Loading Information label. Do not load your vehicle beyond this capacity. Overloading your vehicle may result in reduced tire life, unsafe operating

conditions due to premature tire failure, or unfavorable handling characteristics and could also lead to a serious accident. Loading beyond the specified capacity may also result in failure of other vehicle components.

- **Before taking a long trip, or whenever you heavily load your vehicle, use a tire pressure gauge to ensure that the tire pressures are at the specified level.**
- **For additional information regarding tires, refer to "Important Tire Safety Information" (US) or "Tire Safety Information" (Canada) in the Warranty Information Booklet.**

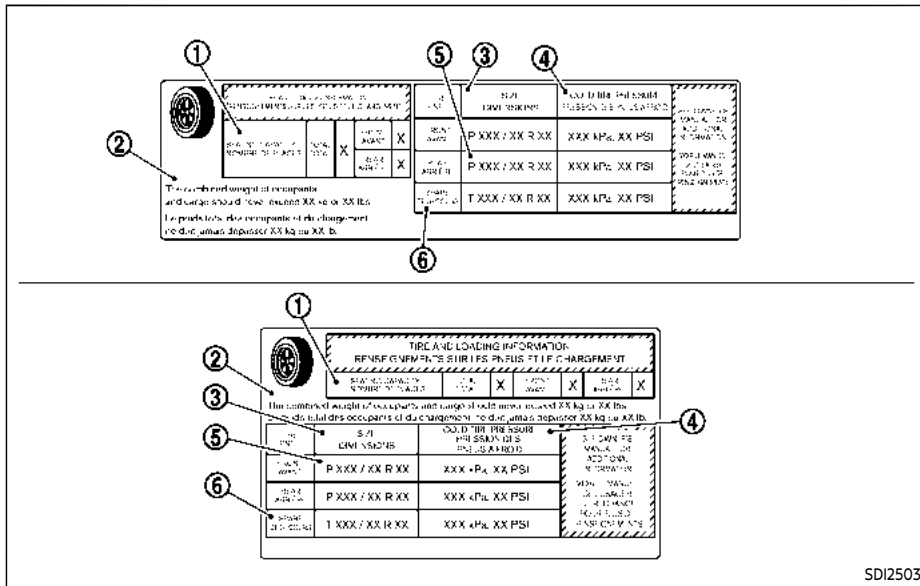

- ④ Cold tire pressure: Inflate the tires to this pressure when the tires are cold. Tires are considered COLD after the vehicle has been parked for 3 or more hours, or driven less than 1 mile (1.6 km) at moderate speeds. The recommended cold tire inflation is set by the manufacturer to provide the best balance of tire wear, vehicle handling, driveability, tire noise, etc., up to the vehicle's GVWR.
- ⑤ Tire size — see "Tire labeling" (P.8-22).
- ⑥ Spare tire size or compact spare tire size (if so equipped)

Tire and Loading Information label

- ① Seating capacity: The maximum number of occupants that can be seated in the vehicle.
- ② Vehicle load limit: See "Vehicle loading information" (P.10-9).

Vehicle loading information" (P.10-9).

- ③ Original size: The size of the tires originally installed on the vehicle at the factory.

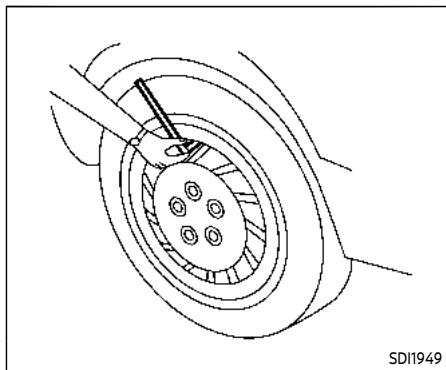

Checking the tire pressure

1. Remove the valve stem cap from the tire.
2. Press the pressure gauge squarely onto the valve stem. Do not press too hard or force the valve stem sideways, or air will escape. If the hissing sound of air escaping from the tire is heard while checking the pressure, reposition the gauge to eliminate this leakage.
3. Remove the gauge.
4. Read the tire pressure on the gauge stem and compare it to the specification shown on the Tire and Loading Information label.
5. Add air to the tire as needed. If too much air is added, press the core of the valve stem briefly with the tip of the gauge stem to release pressure. Recheck the pressure and add or release air as needed.
6. Install the valve stem cap.
7. Check the pressure of all other tires.

	SIZE	COLD TIRE INFLATION PRESSURE
FRONT ORIGINAL TIRE	255/45 R20	280 kPa, 41 PSI
	235/55 R19	320 kPa, 46 PSI*1 280 kPa, 41 PSI*2
REAR ORIGINAL TIRE	255/45 R20	280 kPa, 41 PSI
	235/55 R19	320 kPa, 46 PSI*1 280 kPa, 41 PSI*2

*1: Models with heated steering

*2: Models without heated steering

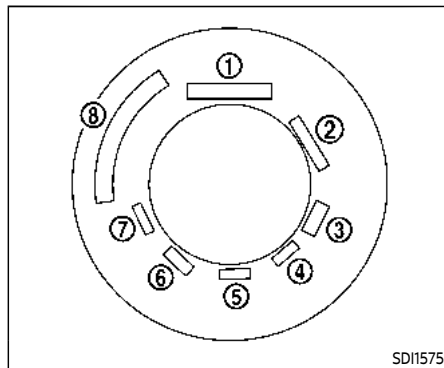

Example

TIRE LABELING

Federal law requires tire manufacturers to place standardized information on the sidewall of all tires. This information identifies and describes the fundamental characteristics of the tire and also provides the tire identification number (TIN) for safety standard certification. The TIN can be used to identify the tire in case of a recall.

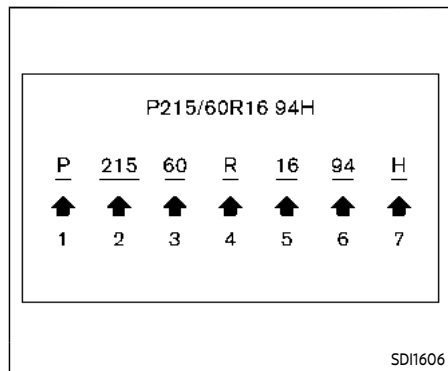

Example

① Tire size (example: P215/60R16 94H)

1. P: The "P" indicates the tire is designed for passenger vehicles. (Not all tires have this information.)
2. Three-digit number (215): This number gives the width in millimeters of the tire from sidewall edge to sidewall edge.
3. Two-digit number (60): This number, known as the aspect ratio, gives the tire's ratio of

height to width.

4. R: The "R" stands for radial.
5. Two-digit number (16): This number is the wheel or rim diameter in inches.
6. Two- or three-digit number (94): This number is the tire's load index. It is a measurement of how much weight each tire can support. You may not find this information on all tires because it is not required by law.
7. H: Tire speed rating. You should not drive the vehicle faster than the tire speed rating.

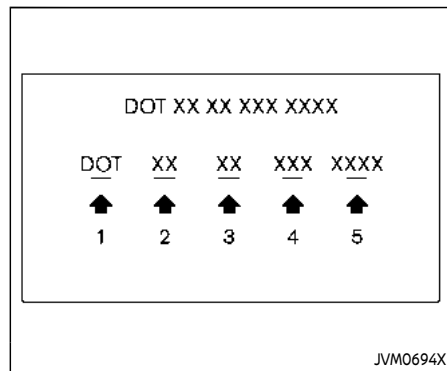

Example (Type A) (if so equipped)

② TIN (Tire Identification Number) for a new tire (example: DOT XX XX XXX XXXX)

1. DOT: Abbreviation for the "Department of Transportation". The symbol can be placed above, below or to the left or right of the Tire Identification Number.
2. Two-digit code: Manufacturer's identification mark
3. Two-digit code: Tire size

4. Three-digit code: Tire type code (Optional)
5. Four numbers represent the week and year the tire was built. For example, the numbers 3103 means the 31st week of 2003. If these numbers are missing, then look on the other sidewall of the tire.

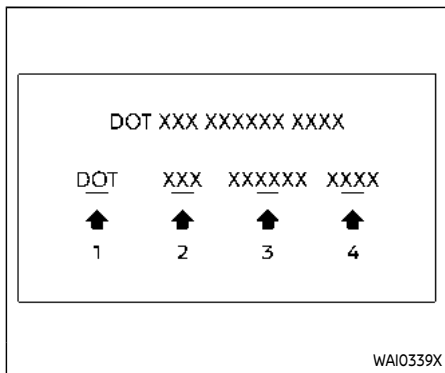

Example (Type B) (if so equipped)

② TIN (Tire Identification Number) for a new tire (example: DOT XXX XXXXXX XXXX)

1. DOT: Abbreviation for the "Department of Transportation". The symbol can be placed above, below or to the left or right of the Tire Identification Number.
2. Three-digit code: Manufacturer's identification mark

3. Six-digit code: Descriptive code used to identify significant characteristics of the tire.
4. Four numbers represent the week and year the tire was built. For example, the numbers 3103 means the 31st week of 2003.

③ Tire ply composition and material

The number of layers or plies of rubber-coated fabric in the tire.

Tire manufacturers also must indicate the materials in the tire, which include steel, nylon, polyester, and others.

④ Maximum permissible inflation pressure

This number is the greatest amount of air pressure that should be put in the tire. Do not exceed the maximum permissible inflation pressure.

⑤ Maximum load rating

This number indicates the maximum load in kilograms and pounds that can be carried by the tire.

When replacing the tires on the vehicle, always use a tire that has the same load rating as the factory installed tire.

⑥ Term of “tubeless” or “tube type”
Indicates whether the tire requires an inner tube (“tube type”) or not (“tubeless”).

⑦ The word “radial”
The word “radial” is shown, if the tire has radial structure.

⑧ Manufacturer or brand name
Manufacturer or brand name is shown.

Other tire-related terminology:

In addition to the many terms that are defined throughout this section, Intended Outboard Sidewall is (1) the sidewall that contains a whitewall, bears white lettering or bears manufacturer, brand and/or model name molding that is higher or deeper than the same molding on the other sidewall of the tire, or (2) the outward facing sidewall of an asymmetrical tire that has a

particular side that must always face outward when mounted on a vehicle.

TYPES OF TIRES



WARNING

- **When changing or replacing tires, be sure all four tires are of the same type (Example: Summer, All Season or Snow) and construction. A NISSAN certified ARIYA dealer may be able to help you with information about tire type, size, speed rating and availability.**
- **Replacement tires may have a lower speed rating than the factory equipped tires, and may not match the potential maximum vehicle speed. Never exceed the maximum speed rating of the tire.**
- **Replacing tires with those not originally specified by NISSAN could affect the proper operation of the TPMS.**
- **For additional information regarding tires, refer to “Important Tire Safety Information” (US) or “Tire Safety Information” (Cana-**

da) in the Warranty Information Booklet.

- **Always use tires of the same type, size, brand, construction and tread pattern on all four wheels. Failure to do so may result in a circumference difference between tires on the front and rear axles which can cause the Vehicle Dynamic Control (VDC) system to malfunction resulting in personal injury or death, excessive tire wear and may damage the transmission and differential gears.**

All season tires

NISSAN specifies all season tires on some models to provide good performance all year, including snowy and icy road conditions. All Season tires are identified by ALL SEASON and/or M&S (Mud and Snow) on the tire sidewall. Snow tires have better snow traction than All Season tires and may be more appropriate in some areas.

Summer tires

NISSAN specifies summer tires on some models to provide superior performance on dry roads. Summer tire performance is substantially reduced in snow and ice. Summer tires do not have the tire traction rating M&S on the tire sidewall.

If you plan to operate your vehicle in snowy or icy conditions, NISSAN recommends the use of SNOW tires or ALL SEASON tires on all four wheels.

Snow tires

If snow tires are needed, it is necessary to select tires equivalent in size and load rating to the original equipment tires. If you do not, it can adversely affect the safety and handling of your vehicle.

Generally, snow tires will have lower speed ratings than factory equipped tires and may not match the potential maximum vehicle speed. Never exceed the maximum speed rating of the tire.

If you install snow tires, they must be the same size, brand, construction and tread pattern on all four wheels.

For additional traction on icy roads, studded tires may be used. However, U.S. states and Canadian provinces prohibit their use. Check local, state and provincial laws before installing studded tires. Skid

and traction capabilities of studded snow tires, on wet or dry surfaces, may be poorer than that of non-studded snow tires.

TIRE CHAINS



CAUTION

- **Tire chains/cables should not be installed on 255/45 R20 tires. Doing so will cause damage to the vehicle.**
- **If you plan to use tire chains/cables, you should install 235/55 R19 tires on your vehicle.**

Use of tire chains may be prohibited according to location. Check the local laws before installing tire chains. When installing tire chains, make sure they are the proper size for the tires on your vehicle and are installed according to the chain manufacturer's suggestions.

Use only SAE Class S chains. Class "S" chains are used on vehicles with restricted tire to vehicle clearance. Vehicles that can use Class "S" chains are designed to meet the SAE standard minimum clearances between the tire and the closest vehicle suspension or body component required to accommodate the

use of a winter traction device (tire chains or cables). The minimum clearances are determined using the factory equipped tire size. Other types may damage your vehicle.

Use chain tensioners when recommended by the tire chain manufacturer to ensure a tight fit. Loose end links of the tire chain must be secured or removed to prevent the possibility of whipping action damage to the fenders or underbody. If possible, avoid fully loading your vehicle when using tire chains. In addition, drive at a reduced speed. Otherwise, your vehicle may be damaged and/or vehicle handling and performance may be adversely affected.

Tire chains must be installed only on the front wheels and not on the rear wheels.

Do not use tire chains on dry roads. Driving with tire chains in such conditions can cause damage to the various mechanisms of the vehicle due to some overstress.

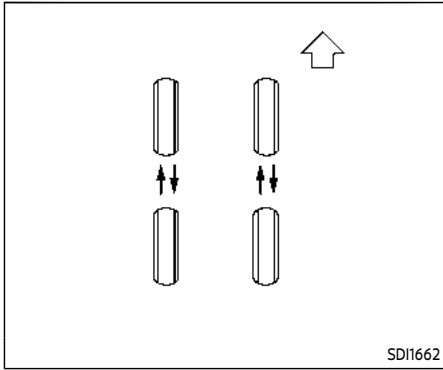

CHANGING WHEELS AND TIRES

Tire rotation

NISSAN recommends rotating the tires at the specified interval shown in the maintenance schedule. (For tire replacing procedures, see "Jacking up vehicle and replacing tires" (P.6-10).)

As soon as possible, tighten the wheel nuts to the specified torque with a torque wrench.

**Wheel nut tightening torque:
80 ft-lb (108 N-m)**

The wheel nuts must be kept tightened to the specification at all times. It is recommended that wheel nuts be tightened to the specification at each tire rotation interval.



WARNING

- After rotating the tires, check and adjust the tire pressure.
- Retighten the wheel nuts when the vehicle has been driven for 600 miles (1,000 km) (also in cases of a flat tire, etc.).
- For additional information regarding tires, refer to "Important Tire Safety Information" (US) or "Tire Safety Information" (Canada) in the Warranty Information Booklet.
- After rotating the tires, do not use the Easy-Fill Tire Alert to adjust the tire pres-

sure. Instead use a gauge to adjust the tires to the correct pressure in accordance with Tire and Loading Information label.

- To ensure proper operation of the Easy-Fill Tire Alert system after a tire rotation, reset and register the sensor to their new installed locations. It is recommended that you visit a NISSAN certified ARIYA dealer for this service.

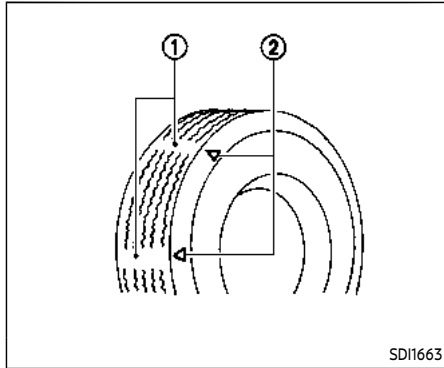

- ① Wear indicator
- ② Wear indicator location mark

Tire wear and damage

WARNING

- Tires should be periodically inspected for wear, cracking, bulging or objects caught in the tread. If excessive wear, cracks, bulging or deep cuts are found, the tire(s) should

be replaced.

- The original tires have built-in tread wear indicators. When wear indicators are visible, the tire(s) should be replaced.
- Tires degrade with age and use. Have tires over 6 years old checked by a qualified technician, because some tire damage may not be obvious. Replace the tires as necessary to prevent tire failure and possible personal injury.
- For additional information regarding tires, refer to "Important Tire Safety Information" (US) or "Tire Safety Information" (Canada) in the Warranty Information Booklet.

Replacing wheels and tires

When replacing a tire, use the same size, tread design, speed rating and load carrying capacity as originally equipped. (See "Specifications" (P.10-4) for recommended types and sizes of tires and wheels.)

WARNING

- The use of tires other than those recommended or the mixed use of tires of different brands, construction (bias, bias-belted or radial), or tread patterns can adversely affect the ride, braking, handling, VDC system, ground clearance, body-to-tire clearance, tire chain clearance, speedometer calibration, headlight aim and bumper height. Some of these effects may lead to accidents and could result in serious personal injury.
- For Two-Wheel Drive (2WD) models, if your vehicle was originally equipped with 4 tires that were the same size and you are only replacing 2 of the 4 tires, install the new tires on the rear axle. Placing new tires on the front

axle may cause loss of vehicle control in some driving conditions and cause an accident and personal injury.

- If the wheels are changed for any reason, always replace with wheels which have the same off-set dimension. Wheels of a different off-set could cause premature tire wear, degrade vehicle handling characteristics and/or interference with the brake discs/drums. Such interference can lead to decreased braking efficiency and/or early brake pad/shoe wear. See "Wheels and tires" (P.10-5) of this manual for wheel off-set dimensions.
- Replacing tires with those not originally specified by NISSAN could affect the proper operation of the TPMS.
- The TPMS sensor may be damaged if it is not handled correctly. Be careful when handling the TPMS sensor.
- When replacing the TPMS sensor, the ID registration may be required. It is recommended you visit a NISSAN certified ARIYA dealer for ID registration.

- Do not use a valve stem cap that is not specified by NISSAN. The valve stem cap may become stuck.
- Be sure that the valve stem caps are correctly fitted. Otherwise the valve may be clogged up with dirt and cause a malfunction or loss of pressure.
- Do not install a damaged or deformed wheel or tire even if it has been repaired. Such wheels or tires could have structural damage and could fail without warning.
- The use of retread tire is not recommended.
- For additional information regarding tires, refer to "Important Tire Safety Information" (US) or "Tire Safety Information" (Canada) in the Warranty Information Booklet.

All-Wheel Drive (AWD) models



CAUTION

Always use tires of the same size, brand, construction (bias, bias-belted or radial), and tread pattern on all four wheels. Failure to do so may reduce AWD performance.

If excessive tire wear is found, it is recommended that all four tires be replaced with tires of the same size, brand, construction and tread pattern. The tire pressure and wheel alignment should also be checked and corrected as necessary. It is recommended you visit a NISSAN certified ARIYA dealer for this service.

Wheel balance

Unbalanced wheels may affect vehicle handling and tire life. Even with regular use, wheels can get out of balance. Therefore, they should be balanced as required.

Wheel balance service should be performed with the wheels off the vehicle. Spin balancing the wheels on the vehicle could lead to mechanical damage.

For additional information regarding tires,

refer to “Important Tire Safety Information” (US) or “Tire Safety Information” (Canada) in the Warranty Information Booklet.

Care of wheels

See “Cleaning exterior” (P.7-2) for details about care of the wheels.

EMERGENCY TIRE PUNCTURE REPAIR KIT

The emergency tire puncture repair kit is supplied to the vehicle instead of a spare tire. The kit must be used for temporarily fixing a minor tire puncture. After using the repair kit, it is recommended that you visit a NISSAN certified ARIYA dealer as soon as possible for tire inspection and repair/replacement.

See “Flat tire” (P.6-3) for more details.

9 Maintenance and schedules

Maintenance requirement	9-2	Explanation of scheduled maintenance items	9-5
General maintenance	9-2	Explanation of scheduled maintenance items	9-5
Scheduled maintenance	9-2	Chassis and body maintenance	9-5
Where to go for service	9-2	Maintenance schedules	9-6
General maintenance	9-2	Additional maintenance items for severe operating conditions	9-6
Explanation of general maintenance items	9-2	EV maintenance schedules (AM67 electric motor)	9-7



MAINTENANCE REQUIREMENT

Some day-to-day and regular maintenance is essential to maintain your vehicle good mechanical condition, and its Electric Vehicle (EV) system performance.

It is the owner's responsibility to make sure that the scheduled maintenance, and general maintenance, is performed.

As the vehicle owner, you are the only one who can ensure that your vehicle receives proper maintenance. You are a vital link in the maintenance chain.

GENERAL MAINTENANCE

General maintenance includes those items which should be checked during normal day-to-day operation. They are essential for proper vehicle operation. It is your responsibility to perform these procedures regularly as prescribed.

Performing general maintenance checks requires minimal mechanical skill and only a few general automotive tools.

These checks or inspections can be done by yourself, a qualified technician or, if you prefer, a NISSAN certified ARIYA dealer.

SCHEDULED MAINTENANCE

The maintenance items listed in this section are required to be serviced at regular intervals. However under severe driving conditions, additional or more frequent maintenance will be required.

WHERE TO GO FOR SERVICE

If maintenance service is required or your vehicle appears to malfunction, have the systems checked and serviced. It is recommended that you visit a NISSAN certified ARIYA dealer for this service.

NISSAN technicians are well-trained specialists and are kept up-to-date with the latest service information through technical bulletins, service tips, and training programs. They are fully qualified to work on NISSAN vehicles **before** work begins.

If your vehicle is involved in a collision, it is recommended that you ask your NISSAN certified ARIYA dealer where the nearest NISSAN Certified Collision Center is located, or go to <http://collision.nissanusa.com>.

You can be confident that a NISSAN certified ARIYA dealer's service department performs the best job to meet the maintenance requirements on your vehicle.

GENERAL MAINTENANCE

During the normal day-to-day operation of the vehicle, general maintenance should be performed regularly as prescribed in this section. If you detect any unusual sounds, vibrations or smells, be sure to check for the cause or a NISSAN certified ARIYA dealer check it promptly. In addition, it is recommended that you visit a NISSAN certified ARIYA dealer if you think that repairs are required.

When performing any checks or maintenance work, closely observe the "Maintenance precautions" (P.8-2).

EXPLANATION OF GENERAL MAINTENANCE ITEMS



WARNING

Failure to follow the procedures listed within this section may result in personal injury.

Additional information on the following items with "" is found in the "Do-it-yourself" section of this manual.

Outside the vehicle

The maintenance items listed here should be performed from time to time, unless otherwise specified.

Doors and motor hood: Check that the doors and motor hood operate properly. Also ensure that all latches lock securely. Lubricate hinges, latches, latch pins, rollers and links if necessary. Make sure that the secondary latch keeps the motor hood from opening when the primary latch is released.

When driving in areas using road salt or other corrosive materials, check lubrication frequently.

Check that the gas stays or struts properly and securely hold the hood, trunk, or rear hatch fully open. If the hood, trunk, or rear hatch is not held open, have the gas stays or struts replaced.

Lights*: Clean the headlights on a regular basis. Make sure that the headlights, stop lights, tail lights, turn signal lights, and other lights are all operating properly and installed securely. Also check headlight aim.

Road wheel nuts (lug nuts)*: When checking the tires, make sure no wheel nuts are missing, and check for any loose wheel nuts. Tighten if necessary.

Tire rotation*: Rotate tires at the specified interval shown in the maintenance schedule.

Tires*: Check the pressure with a gauge often and always prior to long distance trips. If necessary, adjust the pressure in all tires, to the pressure specified. Check carefully for damage, cuts or excessive wear.

Tire Pressure Monitoring System (TPMS) tire pressure sensor: It is recommended that you replace the TPMS tire pressure sensor assembly when the tires are replaced due to wear or age.

Wheel alignment and balance: If the vehicle pulls to either side while driving on a straight and level road, or if you detect uneven or abnormal tire wear, there may be a need for wheel alignment. If the steering wheel or seat vibrates at normal highway speeds, wheel balancing may be needed.

For additional information regarding tires, refer to "Important Tire Safety Information" (US) or "Tire Safety Information" (Canada) in the Warranty Information Booklet.

Windshield: Clean the windshield on a regular basis. Check the windshield at least every six months for cracks or other damage. Have a damaged windshield

repaired by a qualified repair facility. It is recommended that you have a damaged windshield repaired by a NISSAN certified ARIYA dealer, or a NISSAN Certified Collision Center. To locate a collision center in your area, refer to <http://collision.nissanusa.com>.

Windshield wiper blades*: Check for cracks or wear if they do not wipe properly.

Inside the vehicle

The maintenance items listed here should be checked on a regular basis, such as when performing scheduled maintenance, cleaning the vehicle, etc.

Accelerator pedal: Check the pedal for smooth operation and make sure the pedal does not catch or require uneven effort. Keep the floor mat away from the pedal.

Brake pedal: Check the pedal for smooth operation. If the brake pedal suddenly goes down further than normal, the pedal feels spongy or the vehicle seems to take longer to stop, it is recommended that you visit a NISSAN certified ARIYA dealer immediately. Keep the floor mat away from the pedal.

Brakes: Check that the brakes do not pull the vehicle to one side when applied.

Electric shift P (Park) position mechanism: On a steep hill check that the vehicle is held securely while the vehicle is in the P (Park) position without applying any brakes.

Parking brake: Check the parking brake operation regularly. The vehicle should be securely held on a fairly steep hill with only the parking brake applied. If the parking brake needs adjusting, it is recommended that you visit a NISSAN certified ARIYA dealer for this service.

Seats: Check seat position controls such as seat adjusters, seatback recliner, etc., to ensure they operate smoothly and all latches lock securely in every position. Check that the head restraints/headrests move up and down smoothly and the locks (if so equipped) hold securely in all latched positions.

Seat belts: Check that all parts of the seat belt system (for example, buckles, anchors, adjusters and retractors) operate properly and smoothly, and are installed securely. Check the belt webbing for cuts, fraying, wear or damage.

Steering wheel: Check for changes in the steering conditions, such as excessive free play, hard steering or strange noises.

Warning lights and chimes: Make sure all warning lights and chimes are operating

properly.

Windshield defroster: Check that the air emits from the defroster outlets properly and in sufficient quantity when operating the heater or air conditioner.

Windshield wiper and washer*: Check that the wipers and washer operate properly and that the wipers do not streak.

Under the hood and vehicle

The maintenance items listed here should be checked periodically.

12-volt battery (except for maintenance free batteries)*: Check the fluid level in each cell. The fluid should be at the bottom of the filler opening. Vehicles operated in high temperatures or under severe conditions require frequent checks of the 12-volt battery fluid level.

NOTE:

Care should be taken to avoid situations that can lead to potential battery discharge and potential no-start conditions such as:

1. **Installation or extended use of electronic accessories that consume battery power when the EV system is not running (Phone chargers, GNSS, DVD players, etc.)**

2. **Vehicle is not driven regularly and/ or only driven short distances.**

In these cases, the battery may need to be charged to maintain battery health.

Brake fluid level*: Make sure that the brake fluid levels are between the MAX and MIN lines on the reservoir.

Coolant level*: Check the coolant level when the high voltage parts are cold. Make sure that the coolant level is between the MAX and MIN lines on the reservoir.

Fluid leaks: Check under the vehicle for water or other fluid leaks after the vehicle has been parked for a while. Water dripping from the air conditioner after use is normal. If you should notice any leaks, check for cause and have it corrected immediately.

Radiator and hoses: Check the front of the radiator and clean off any dirt, insects, leaves, etc., that may have accumulated. Make sure the hoses have no cracks, deformation, rot or loose connections.

Underbody: The underbody is frequently exposed to corrosive substances such as those used on icy roads or to control dust. It is very important to remove these substances, otherwise rust will form on the floor pan and frame. At the end of winter, the underbody should be thor-

EXPLANATION OF SCHEDULED MAINTENANCE ITEMS

oroughly flushed with plain water, being careful to clean those areas where mud and dirt may accumulate. For additional information, see "Cleaning exterior" (P.7-2).

Windshield washer fluid*: Check that there is an adequate amount of fluid in the reservoir.

The following descriptions are provided to give you a better understanding of the scheduled maintenance items that should be regularly checked or replaced. The maintenance schedule indicates at which mileage/time intervals each item requires service.

In addition to scheduled maintenance, your vehicle requires that some items be checked during normal day-to-day operation. For additional information, see "General maintenance" (P.9-2).

Items marked with "*" are recommended by NISSAN for reliable vehicle operation. You are not required to perform maintenance on these items in order to maintain the warranties which come with your NISSAN. Other maintenance items and intervals are required.

When applicable, additional information can be found in the "Do-it-yourself" section of this manual.

EXPLANATION OF SCHEDULED MAINTENANCE ITEMS

EV System Charging Port*: Check the charging port for any signs of contamination, dust, sand etc.

Charging Port Rubber Cap*: Use only compressed air with proper eye protection to clean any contamination from the sealing cap.

Coolant: Replace coolant at the interval specified below. When adding or replacing coolant, be sure to use only Genuine NISSAN Long Life Antifreeze/Coolant (Blue) or equivalent with the proper mixture. (Refer to the Owner's Manual to determine the proper mixture for your area.) The recommended service interval of the factory fill coolant is 125,000 miles (200,000 km) or 15 years, whichever comes first. Subsequent replacement of Genuine NISSAN Long Life Antifreeze/Coolant (Blue) should occur every 75,000 miles (120,000 km) or 5 years, whichever comes first.

NOTE:

Mixing any other type of coolant or the use of nondistilled water will reduce the recommended service interval of the coolant.

CHASSIS AND BODY MAINTENANCE

Brake lines and cables:

Visually inspect for proper installation. Check for chafing, cracks, deterioration, and signs of leaking. Replace any deteriorated or damaged parts immediately.

Brake pads and rotors:

Check for wear, deterioration and fluid leaks. Replace any deteriorated or damaged parts immediately.

MAINTENANCE SCHEDULES

In-cabin microfilter:

Replace at specified intervals. When driving for prolonged periods in dusty conditions, replace the filter more frequently.

Steering gear and linkage, axle and suspension parts, drive shaft boots:

Check for damage, looseness, and leakage of oil or grease. Under severe driving conditions, inspect more frequently.

Tire rotation:

Rotate tires at the specified interval shown in the maintenance schedule. When rotating tires, check for damage and uneven wear. Replace if necessary.

Reduction Gear Oil: Visually inspect for signs of leakage at specified intervals.

To help ensure smooth, safe and economical driving, NISSAN provides two maintenance schedules that may be used, depending upon the conditions in which you usually drive. These schedules contain both distance and time intervals, up to 120,000 miles (192,000 km)/96 months. For most people, the odometer reading will indicate when service is needed. However, if you drive very little, your vehicle should be serviced at the regular time intervals shown in the schedule.

After 120,000 miles (192,000 km)/96 months, continue maintenance at the same mileage/time intervals.

ADDITIONAL MAINTENANCE ITEMS FOR SEVERE OPERATING CONDITIONS

Additional maintenance items for severe operating conditions; should be performed on vehicles that are driven under especially demanding conditions. Additional maintenance items should be performed if you primarily operate your vehicle under the following conditions:

- Repeated short trips of less than 5 miles (8 km).
- Repeated short trips of less than 10 miles (16 km) with outside temperatures remaining below freezing.

- Operating in hot weather in stop-and-go "rush hour" traffic.
- Low speed driving for long distances, such as police, taxi or door-to-door delivery use.
- Driving in dusty conditions.
- Driving on rough, muddy or salt spread roads.
- Using a car-top carrier.

If your vehicle is mainly operated under the severe conditions, follow the severe use maintenance intervals shown in the maintenance schedule.

EV MAINTENANCE SCHEDULES (AM67 electric motor)

The following shows the maintenance schedule. Choose the maintenance schedule needed based on your vehicle driving conditions.

After 120,000 miles (192,000 km)/96 months, continue maintenance at the same mileage/time interval.

7,500 miles/(12,000 km)/6 months

Perform at number of miles, kilometers or months, whichever comes first.

Standard maintenance:

Inspections:

- Horn, lights, signals, wipers, liftgate/ hood lift supports
- Battery terminals and cables, battery test
- Tire pressure, treadwear and depth
- Suspension components (shocks, sub-frame, tie rods)
- Charging port
- Charging port rubber cap

Essential:

- Tire rotation

Severe use maintenance:

Inspections:

- Axle & suspension parts
- Brake pads & rotors
- Drive shaft boots
- Front suspension ball joints
- Steering gear and linkage
- Steering linkage ball joints

15,000 miles/(24,000 km)/ 12 months

Perform at number of miles, kilometers or months, whichever comes first.

Standard maintenance:

Inspections:

- Brake lines & cables
- Brake pads & rotors
- Charging port
- Charging port rubber cap
- Cooling system
- Drive shaft boots
- Reduction gear oil
- Horn, lights, signals, wipers, liftgate/ hood lift supports
- Battery terminals and cables, battery test
- Tire pressure, treadwear and depth
- Suspension components (shocks, sub-frame, tie rods)

Essential:

- Replace in-cabin microfilter
- Tire rotation

Severe use maintenance:

Inspections:

- Axle & suspension parts
- Front suspension ball joints
- Steering gear and linkage
- Steering linkage ball joints

Essential:

- Replace brake fluid

22,500 miles/(36,000 km)/ 18 months

Perform at number of miles, kilometers or months, whichever comes first.

Standard maintenance:

Inspections:

- Charging port
- Charging port rubber cap
- Inspect Intelligent Key battery (1)
- Horn, lights, signals, wipers, liftgate/ hood lift supports
- Battery terminals and cables, battery test
- Tire pressure, treadwear and depth
- Suspension components (shocks, sub-frame, tie rods)

Essential:

- Tire rotation

Severe use maintenance:

Inspections:

- Axle & suspension parts
- Brake pads & rotors
- Drive shaft boots
- Front suspension ball joints
- Steering gear and linkage
- Steering linkage ball joints

(1) Performed based on the number of service months only.

30,000 miles/(48,000 km)/ 24 months

Perform at number of miles, kilometers or months, whichever comes first.

Standard maintenance:

Inspections:

- Axle & suspension parts
- Brake lines & cables
- Brake pads & rotors
- Charging port
- Charging port rubber cap
- Cooling system
- Drive shaft boots
- Front suspension ball joints
- Reduction gear oil
- Steering gear and linkage
- Steering linkage ball joints
- Horn, lights, signals, wipers, liftgate/ hood lift supports
- Battery terminals and cables, battery test
- Tire pressure, treadwear and depth
- Suspension components (shocks, sub-frame, tie rods)

Essential:

- Replace brake fluid
- Replace in-cabin microfilter
- Tire rotation

Severe use maintenance:

Not applicable. Proceed to next interval.

37,500 miles/(60,000 km)/ 30 months

Perform at number of miles, kilometers or months, whichever comes first.

Standard maintenance:

Inspections:

- Charging port
- Charging port rubber cap
- Horn, lights, signals, wipers, liftgate/ hood lift supports
- Battery terminals and cables, battery test
- Tire pressure, treadwear and depth
- Suspension components (shocks, sub-frame, tie rods)

Essential:

- Tire rotation

Severe use maintenance:

Inspections:

- Axle & suspension parts
- Brake pads & rotors
- Drive shaft boots
- Front suspension ball joints
- Steering gear and linkage
- Steering linkage ball joints

45,000 miles/(72,000 km)/ 36 months

Perform at number of miles, kilometers or months, whichever comes first.

Standard maintenance:

Inspections:

- Brake lines & cables
- Brake pads & rotors
- Charging port
- Charging port rubber cap
- Cooling system
- Drive shaft boots
- Reduction gear oil
- Horn, lights, signals, wipers, liftgate/ hood lift supports
- Battery terminals and cables, battery test
- Tire pressure, treadwear and depth
- Suspension components (shocks, sub-frame, tie rods)

Essential:

- Replace Intelligent key battery (1)
- Replace in-cabin microfilter
- Tire rotation

Severe use maintenance:

Inspections:

- Axle & suspension parts
- Front suspension ball joints
- Steering gear and linkage
- Steering linkage ball joints

Essential:

- Replace brake fluid
- (1) Performed based on the number of service months only.

52,500 miles/(84,000 km)/ 42 months

Perform at number of miles, kilometers or months, whichever comes first.

Standard maintenance:

Inspections:

- Charging port
- Charging port rubber cap
- Horn, lights, signals, wipers, liftgate/ hood lift supports
- Battery terminals and cables, battery test
- Tire pressure, treadwear and depth
- Suspension components (shocks, sub-frame, tie rods)

Essential:

- Tire rotation

Severe use maintenance:

Inspections:

- Axle & suspension parts
- Brake pads & rotors
- Drive shaft boots
- Front suspension ball joints
- Steering gear and linkage
- Steering linkage ball joints

60,000 miles/(96,000 km)/ 48 months

Perform at number of miles, kilometers or months, whichever comes first.

Standard maintenance:

Inspections:

- Axle & suspension parts
- Brake lines & cables
- Brake pads & rotors
- Charging port
- Charging port rubber cap
- Cooling system
- Drive shaft boots
- Front suspension ball joints
- Reduction gear oil
- Steering gear and linkage
- Steering linkage ball joints
- Horn, lights, signals, wipers, liftgate/ hood lift supports
- Battery terminals and cables, battery test
- Tire pressure, treadwear and depth
- Suspension components (shocks, sub-frame, tie rods)

Essential:

- Replace brake fluid
- Replace in-cabin microfilter
- Tire rotation

Severe use maintenance:

Not applicable. Proceed to next interval.

67,500 miles/(108,000 km)/ 54 months

Perform at number of miles, kilometers or months, whichever comes first.

Standard maintenance:

Inspections:

- Charging port
- Charging port rubber cap
- Horn, lights, signals, wipers, liftgate/ hood lift supports
- Battery terminals and cables, battery test
- Tire pressure, treadwear and depth
- Suspension components (shocks, sub-frame, tie rods)

Essential:

- Replace Intelligent key battery (1)
- Tire rotation

Severe use maintenance:

Inspections:

- Axle & suspension parts
- Brake pads & rotors
- Drive shaft boots
- Front suspension ball joints
- Steering gear and linkage
- Steering linkage ball joints

(1) Performed based on the number of service months only.

75,000 miles/(120,000 km)/ 60 months

Perform at number of miles, kilometers or months, whichever comes first.

Standard maintenance:

Inspections:

- Brake lines & cables
- Brake pads & rotors
- Charging port
- Charging port rubber cap
- Cooling system
- Drive shaft boots
- Reduction gear oil
- Horn, lights, signals, wipers, liftgate/ hood lift supports
- Battery terminals and cables, battery test
- Tire pressure, treadwear and depth
- Suspension components (shocks, sub-frame, tie rods)

Essential:

- Replace in-cabin microfilter
- Tire rotation

Severe use maintenance:

Inspections:

- Axle & suspension parts
- Front suspension ball joints
- Steering gear and linkage
- Steering linkage ball joints

Essential:

- Replace brake fluid

82,500 miles/(132,000 km)/ 66 months

Perform at number of miles, kilometers or months, whichever comes first.

Standard maintenance:

Inspections:

- Charging port
- Charging port rubber cap
- Horn, lights, signals, wipers, liftgate/ hood lift supports
- Battery terminals and cables, battery test
- Tire pressure, treadwear and depth
- Suspension components (shocks, sub-frame, tie rods)

Essential:

- Tire rotation

Severe use maintenance:

Inspections:

- Axle & suspension parts
- Brake pads & rotors
- Drive shaft boots
- Front suspension ball joints
- Steering gear and linkage
- Steering linkage ball joints

90,000 miles/(144,000 km)/ 72 months

Perform at number of miles, kilometers or months, whichever comes first.

Standard maintenance:

Inspections:

- Axle & suspension parts
- Brake lines & cables
- Brake pads & rotors
- Charging port
- Charging port rubber cap
- Cooling system
- Drive shaft boots
- Front suspension ball joints
- Reduction gear oil
- Steering gear and linkage
- Steering linkage ball joints
- Horn, lights, signals, wipers, liftgate/ hood lift supports
- Battery terminals and cables, battery test
- Tire pressure, treadwear and depth
- Suspension components (shocks, sub-frame, tie rods)

Essential:

- Replace Intelligent key battery (1)
- Replace brake fluid
- Replace in-cabin microfilter
- Tire rotation

Severe use maintenance:

Not applicable. Proceed to next interval.

(1) Performed based on the number of service months only.

97,500 miles/(156,000 km)/ 78 months

Perform at number of miles, kilometers or months, whichever comes first.

Standard maintenance:

Inspections:

- Charging port
- Charging port rubber cap
- Horn, lights, signals, wipers, liftgate/ hood lift supports
- Battery terminals and cables, battery test
- Tire pressure, treadwear and depth
- Suspension components (shocks, sub-frame, tie rods)

Essential:

- Tire rotation

Severe use maintenance:

Inspections:

- Axle & suspension parts
- Brake pads & rotors
- Drive shaft boots
- Front suspension ball joints
- Steering gear and linkage
- Steering linkage ball joints

105,000 miles/(168,000 km)/ 84 months

Perform at number of miles, kilometers or months, whichever comes first.

Standard maintenance:

Inspections:

- Brake lines & cables
- Brake pads & rotors
- Charging port
- Charging port rubber cap
- Cooling system
- Drive shaft boots
- Reduction gear oil
- Horn, lights, signals, wipers, liftgate/ hood lift supports
- Battery terminals and cables, battery test
- Tire pressure, treadwear and depth
- Suspension components (shocks, sub-frame, tie rods)

Essential:

- Replace in-cabin microfilter
- Tire rotation

Severe use maintenance:

Inspections:

- Axle & suspension parts
- Front suspension ball joints
- Steering gear and linkage
- Steering linkage ball joints

Essential:

- Replace brake fluid

112,500 miles/(180,000 km)/ 90 months

Perform at number of miles, kilometers or months, whichever comes first.

Standard maintenance:

Inspections:

- Charging port
- Charging port rubber cap
- Horn, lights, signals, wipers, liftgate/ hood lift supports
- Battery terminals and cables, battery test
- Tire pressure, treadwear and depth
- Suspension components (shocks, sub-frame, tie rods)

Essential:

- Replace Intelligent key battery (1)
- Tire rotation

Severe use maintenance:

Inspections:

- Axle & suspension parts
- Brake pads & rotors
- Drive shaft boots
- Front suspension ball joints
- Steering gear and linkage
- Steering linkage ball joints

(1) Performed based on the number of service months only

120,000 miles/(192,000 km)/ 96 months

Perform at number of miles, kilometers or months, whichever comes first.

Standard maintenance:

Inspections:

- Axle & suspension parts
- Brake lines & cables
- Brake pads & rotors
- Charging port
- Charging port rubber cap
- Cooling system
- Drive shaft boots
- Front suspension ball joints
- Reduction gear oil
- Steering gear and linkage
- Steering linkage ball joints
- Horn, lights, signals, wipers, liftgate/ hood lift supports
- Battery terminals and cables, battery test
- Tire pressure, treadwear and depth
- Suspension components (shocks, sub-frame, tie rods)

Essential:

- Replace brake fluid
- Replace in-cabin microfilter
- Tire rotation

Severe use maintenance:

Not applicable.

10 Technical and consumer information

Recommended fluids/lubricants and capacities	10-2	Vehicle load capacity	10-10
Air conditioning system refrigerant and lubricant recommendations	10-3	Securing the load	10-12
Specifications	10-4	Loading tips	10-12
Charging system	10-4	Measurement of weights	10-13
Motor	10-5	Towing a trailer (AWD models)	10-13
Wheels and tires	10-5	Maximum load limits	10-13
Dimensions and weights	10-5	Maximum Gross Vehicle Weight (GVW)/ maximum Gross Axle Weight (GAW)	10-15
When traveling or registering in another country	10-5	Towing load/specification	10-17
Vehicle identification	10-6	Towing safety	10-18
Vehicle Identification Number (VIN) plate	10-6	Flat towing	10-22
Vehicle identification number (chassis number) (if so equipped)	10-6	Uniform tire quality grading	10-23
Traction motor serial number	10-6	Treadwear	10-23
F.M.V.S.S./C.M.V.S.S. certification label	10-7	Traction AA, A, B and C	10-23
Tire and Loading Information label	10-7	Temperature A, B and C	10-23
Air conditioner specification label	10-7	Reporting safety defects	10-24
Installing front license plate	10-9	Event Data Recorders (EDR)	10-25
Vehicle loading information	10-9	Additional data recording	10-25
Terms	10-9	NISSAN SOFTWARE LICENSE	10-27
		Owner's manual/service manual order information	10-27

RECOMMENDED FLUIDS/ LUBRICANTS AND CAPACITIES

The following are approximate capacities. The actual refill capacities may be slightly different. When refilling, follow the procedure described in the "Do-it-yourself" section to determine the proper refill capacity.

Fluid type		Capacity (approximate)			Recommended Fluids/Lubricants
		Metric Measure	US Measure	Imperial Measure	
Cooling system coolant	For electric powertrain (with reservoir) (2WD)	3.8L	4 qt	3-3/8 qt	· Pre-diluted Genuine NISSAN Long Life Antifreeze/Coolant (blue) or equivalent
	For electric powertrain (with reservoir) (AWD)	5.8L	6-1/8 qt	5-1/8 qt	
	For Li-ion battery (with reservoir)	2.9 L	3-1/8 qt	2-1/2 qt	
Gear box oil		0.87 L	7/8 qt	3/4 qt	· Genuine NISSAN Gear Oil NFX 75W · Using reduction gear oil other than Genuine NISSAN Gear Oil NFX 75W will cause deterioration in drivability and reduction gear durability, and may damage the reduction gear, which is not covered by the NISSAN's New Vehicle Limited Warranty.
Rear final drive oil		0.755 L	3/4 qt	5/8 qt	
Brake fluid		Refill to the proper level according to the instructions, see "Brake fluid" (P.8-7).			· Genuine NISSAN Super Heavy Duty Brake Fluid or equivalent DOT 3 · Available in mainland U.S.A. through a NISSAN certified ARIYA dealer.
Multi-purpose grease		—	—	—	· NLGI No. 2 (Lithium soap base)
Air conditioning system refrigerant		—	—	—	· HFO-1234yf (R-1234yf) · For additional information, see "Air conditioner specification label" (P.10-7).
Air conditioning system lubricants		—	—	—	· NISSAN A/C System Oil ND-OIL11 or equivalent.
Windshield washer fluid (US)		2.0 L	1/2 gal	1/2 gal	· Genuine NISSAN Windshield Washer Concentrate Cleaner & Antifreeze fluid or equivalent
Windshield washer fluid (Canada)		4.2 L	1-1/8 gal	7/8 gal	

AIR CONDITIONING SYSTEM REFRIGERANT AND LUBRICANT RECOMMENDATIONS

The air conditioning system in your NISSAN vehicle must be charged with the refrigerant, HFO-1234yf (R-1234yf), and the compressor oil, ND-OIL11 or the equivalent.



CAUTION

The use of any other refrigerant or oil will cause severe damage to the air conditioning system and will require the replacement of all air conditioner system components.

The refrigerant, HFO-1234yf (R-1234yf), in your NISSAN vehicle will not harm the earth's ozone layer. Although this refrigerant does not affect the earth's atmosphere, certain governmental regulations require the recovery and recycling of any refrigerant during automotive air conditioning system service. Air conditioner system should only be serviced by trained and certified technicians to ensure proper and safe operation (SAE J2845). A NISSAN certified ARIYA dealer has the trained technicians and equipment needed to recover and recycle your air conditioning

system refrigerant. Only new and SAE J2842 certified evaporator(s) or inner condenser (if so equipped) shall be used as replacement parts.

A damaged or leaking air conditioning evaporator or inner condenser (if so equipped) shall never be repaired or replaced with one removed from a used or salvaged vehicle. To replace a damaged or leaking evaporator or inner condenser (if so equipped), use only new and SAE J2842 certified evaporator(s). It is recommended that you visit a NISSAN certified ARIYA dealer when servicing your air conditioner system.

SPECIFICATIONS

CHARGING SYSTEM

Rated input voltage	AC120V, 240V (single phase)
Rated input frequency	60Hz
Maximum rated current	30A
Charging modes / Type of connection	Mode 2 / Case B (Normal charge with NISSAN Genuine portable type EVSE - if so equipped) Mode 3 / Case B/C (Normal charge with public charging station, etc.) Mode 4 / Case C (Quick charge)
Required installation (over current protection)	The methods of protection against over current and over voltage shall be in accordance with national codes. Suitable over current protection devices for the wiring of houses or buildings shall be installed.
IP Degree	IP44: When the NISSAN EVSE (if so equipped) is connected to the normal charge port.
Operating temperature	Same as vehicle operating temperature
Storage temperature	Same as vehicle storage temperature
Altitude	Up to 9,843 ft (3,000 m)
Applicable standard	SAE J1772: 2010 EN61851-1: 2011 EN61851-21: 2002 IEC61851-1: 2010 IEC61851-21: 2001 EN61000-6-1: 2007 EN61000-6-3: 2007
Adaptors	Do not use an extension cable or electrical adaptor except for Genuine NISSAN Adapter.

MOTOR

Model	AM67
-------	------

WHEELS AND TIRES

Road wheel

Type	Size	Offset in (mm)
Conventional	19 × 7.5J	1.77 (45)
	20 × 8J	1.97 (50)
Spare	- (*)	- (*)

*: The emergency tire puncture repair kit is supplied.

Tire

Type	Size	Pressure PSI (kPa) [Cold]
Conventional	235/55 R19*1	Front: 41 (280)
		Rear: 41 (280)
	235/55 R19*2	Front: 46 (320) Rear: 46 (320)
	255/45 R20	Front: 41 (280) Rear: 41 (280)

*1: Models with heated steering

*2: Models without heated steering

DIMENSIONS AND WEIGHTS

Overall length	in (mm)	182.9 (4,645)
Overall width	in (mm)	74.8 (1,900)
Overall height	in (mm)	65.4 (1,660)*1 65.7 (1,670)*2
Front tread	in (mm)	64.4 (1,635)*3 64.0 (1,625)*4
Rear tread	in (mm)	64.4 (1,635)*5*6 64.6 (1,640)*7 64.2 (1,630)*8
Wheelbase	in (mm)	109.3 (2,775)
Gross Vehicle Weight Rating (GVWR)	lb (kg)	See the F.M.V.S.S. or C.M.V.S.S. certification label on the driver's side center pillar.
Gross Axle Weight Rating (GAWR)		
Front	lb (kg)	
Rear	lb (kg)	

*1: Models without ProPILOT Assist 2.0

*2: Models with ProPILOT Assist 2.0

*3: 19 inch wheel models

*4: 20 inch wheel models

*5: 2WD models

*6: AWD models with 19 inch wheel and 66 kWh battery

*7: AWD models with 19 inch wheel and 91 kWh battery

*8: AWD models with 20 inch wheel and 91 kWh battery

WHEN TRAVELING OR REGISTERING IN ANOTHER COUNTRY

When planning to travel in another country, you should first find out if the charging equipment is compatible with that country's electrical system.

When transferring the registration of your vehicle to another country, state, province or district, it may be necessary to modify the vehicle to meet local laws and regulations.

The laws and regulations for motor vehicle safety standards vary according to the country, state, province or district; therefore, vehicle specifications may differ.

When any vehicle is to be taken into another country, state, province or district and registered, its modifications, transportation, and registration are the responsibility of the user. NISSAN is not responsible for any inconvenience that may result.

VEHICLE IDENTIFICATION

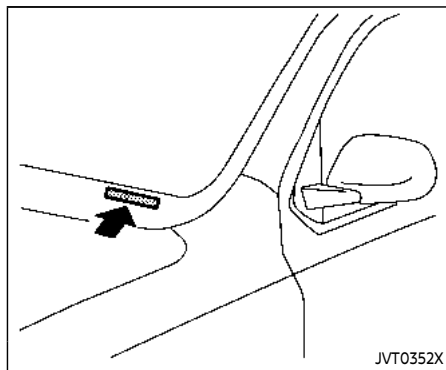

VEHICLE IDENTIFICATION NUMBER (VIN) PLATE

The vehicle identification number plate is attached as shown. This number is the identification for your vehicle and is used in the vehicle registration.

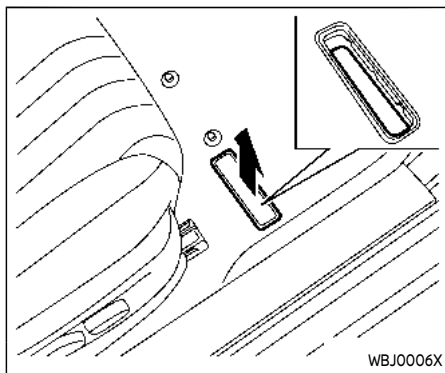

VEHICLE IDENTIFICATION NUMBER (chassis number) (if so equipped)

The vehicle identification number is located as shown.

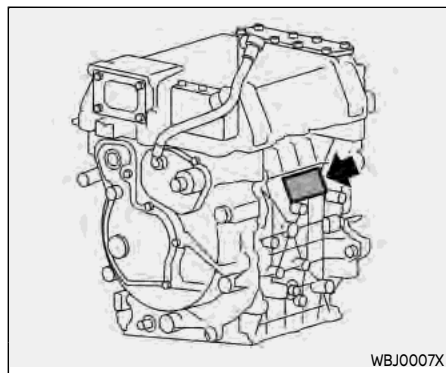

TRACTION MOTOR SERIAL NUMBER

The serial number of the traction motor is stamped on the traction motor as shown.

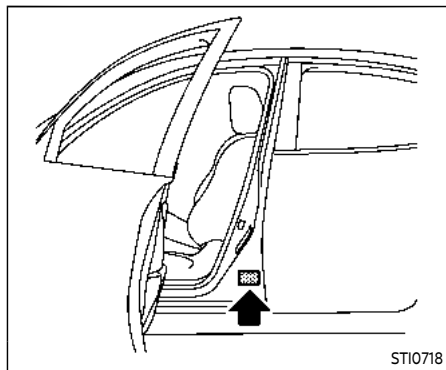

F.M.V.S.S./C.M.V.S.S. CERTIFICATION LABEL

The Federal/Canadian Motor Vehicle Safety Standards (F.M.V.S.S./C.M.V.S.S.) certification label is affixed as shown. This label contains valuable vehicle information, such as: Gross Vehicle Weight Ratings (GVWR), Gross Axle Weight Rating (GAWR), month and year of manufacture, Vehicle Identification Number (VIN), etc. Review it carefully.

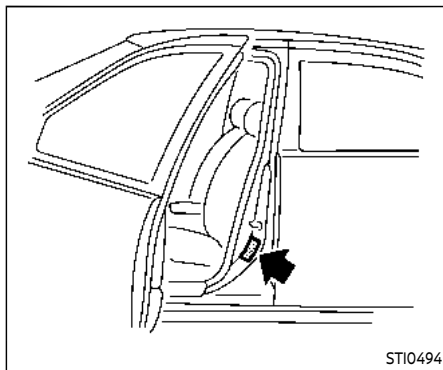



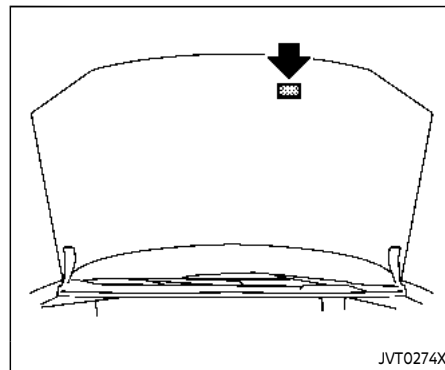

TIRE AND LOADING INFORMATION LABEL

The cold tire pressure is shown on the Tire and Loading Information label affixed to the pillar as shown.



AIR CONDITIONER SPECIFICATION LABEL

The air conditioner specification label is affixed to the underside of the hood as shown.

Air conditioner specification label symbols:		
Symbol Name	Reference	Graphic
Caution	ISO 7000 0434	
Air Conditioning System (MAC)	ISO 2575 D01	
MAC System Lubricant Type (PAG-POE)		
Requires Registered Technician to Service MAC System		
Flammable Refrigerant		

INSTALLING FRONT LICENSE PLATE

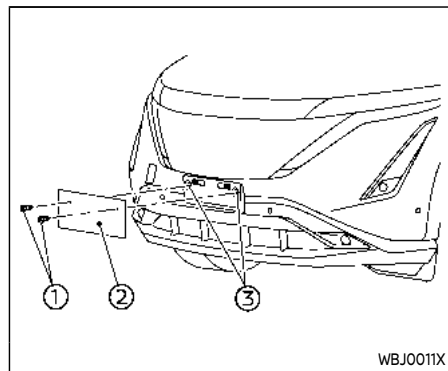

To mount the front license plate ②, attach the licence plate to the location marks (small dimples) ③ of the bumper using the two screws ① provided.

VEHICLE LOADING INFORMATION



WARNING

- It is extremely dangerous to ride in a cargo area inside the vehicle. In a collision, people riding in these areas are more likely to be seriously injured or killed.
- Do not allow people to ride in any area of your vehicle that is not equipped with seats and seat belts.
- Be sure everyone in your vehicle is in a seat and using a seat belt properly.

TERMS

It is important to familiarize yourself with the following terms before loading your vehicle:

- Curb Weight (actual weight of your vehicle) - vehicle weight including: standard and optional equipment, fluids, emergency tools, and spare tire assembly. This weight **does not** include

passengers and cargo.

- GVW (Gross Vehicle Weight) - curb weight plus the combined weight of passengers and cargo.
- GVWR (Gross Vehicle Weight Rating) - maximum total combined weight of the unloaded vehicle, passengers, cargo, hitch, trailer tongue load and any other optional equipment. This information is located on the F.M.V.S.S./C.M.V.S.S. label.
- GAWR (Gross Axle Weight Rating) - maximum weight (load) limit specified for the front or rear axle. This information is located on the F.M.V.S.S./C.M.V.S.S. label.
- GCWR (Gross Combined Weight Rating) - The maximum total weight rating of the vehicle, passengers, cargo, and trailer.
- Vehicle Capacity Weight, Load limit, Total load capacity - maximum total weight limit specified of the load (passengers and cargo) for the vehicle. This is the maximum combined weight of occupants and cargo that can

be loaded into the vehicle. If the vehicle is used to tow a trailer, the trailer tongue weight must be included as part of the cargo load. This information is located on the Tire and Loading Information label.

- Cargo capacity - permissible weight of cargo, the subtracted weight of occupants from the load limit.

VEHICLE LOAD CAPACITY

Do not exceed the load limit of your vehicle shown as "The combined weight of occupants and cargo" on the Tire and Loading Information label. Do not exceed the number of occupants shown as "Seating Capacity" on the Tire and Loading Information label.

To get "the combined weight of occupants and cargo", add the weight of all occupants, then add the total luggage weight. Examples are shown in the following illustration.

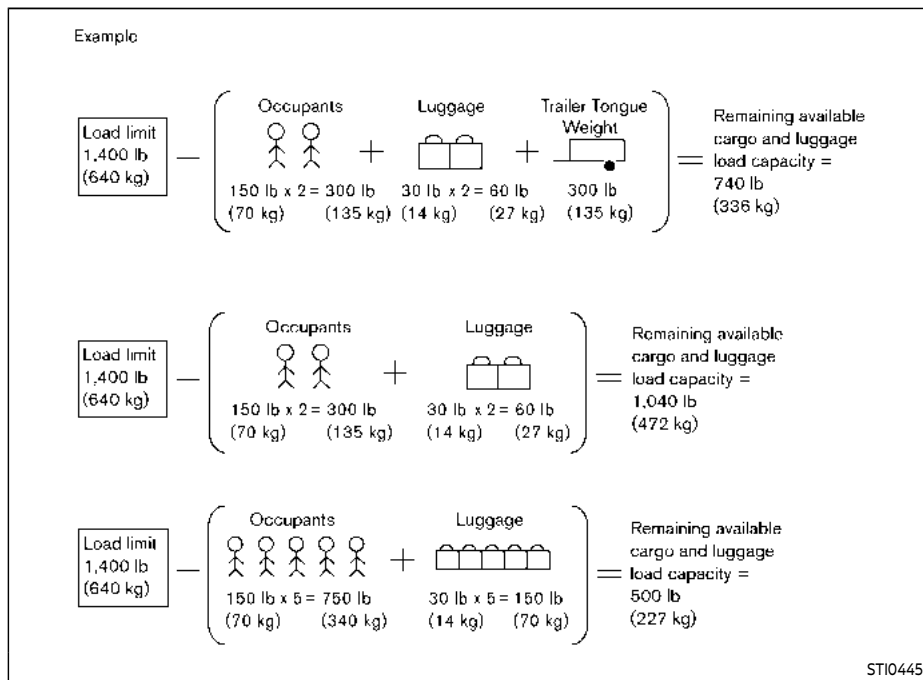

Steps For Determining Correct Load Limit

1. Locate the statement “The combined weight of occupants and cargo should never exceed XXX kg or XXX lbs” on your vehicle’s placard.
2. Determine the combined weight of the driver and passengers that will be riding in your vehicle.
3. Subtract the combined weight of the driver and passengers from XXX kg or XXX lbs.
4. The resulting figure equals the available amount of cargo and luggage load capacity. For example, if the XXX amount equals 1400 lbs. and there will be five 150 lb. passengers in your vehicle, the amount of available cargo and luggage load capacity is 650 lbs. (1400 - 750 (5 x 150) = 650 lbs)
5. Determine the combined weight of luggage and cargo being loaded on the vehicle. That weight may not safely exceed

the available cargo and luggage load capacity calculated in Step 4.

6. If your vehicle will be towing a trailer, load from your trailer will be transferred to your vehicle. Consult this manual to determine how this reduces the available cargo and luggage load capacity of your vehicle.

For 2WD models:

Towing a trailer with a vehicle that is not intended for towing may result in an accident involving injury or death.



WARNING

Do not tow a trailer with your vehicle. Towing a trailer may result in an accident involving injury or death.

Before driving a loaded vehicle, confirm that you do not exceed the Gross Vehicle Weight Rating (GVWR) or the Gross Axle Weight

Rating (GAWR) for your vehicle. (See “Measurement of weights” (P.10-13).)

Also check tires for proper inflation pressures. See the Tire and Loading Information label.

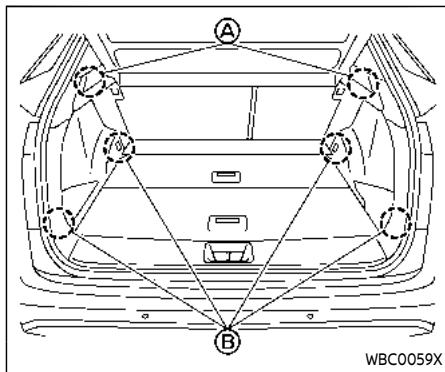

SECURING THE LOAD

There are luggage hooks located in the cargo area as shown. The hooks can be used to secure cargo with ropes or other types of straps.

Do not apply a total load of more than 11 lbs. (5 kg) (A) or 22 lbs. (10 kg) (B) to a single hook when securing cargo.

WARNING

- Properly secure all cargo with ropes or straps to help prevent it from sliding or shifting. Do not place cargo higher than the seat-

backs. In a sudden stop or collision, unsecured cargo could cause personal injury.

- The child restraint top tether strap may be damaged by contact with items in the cargo area. Secure any items in the cargo area. Your child could be seriously injured or killed in a collision if the top tether strap is damaged.
- Do not load your vehicle any heavier than the GVWR or the maximum front and rear GAWRs. If you do, parts of your vehicle can break, tire damage could occur, or it can change the way your vehicle handles. This could result in loss of control and cause personal injury.

LOADING TIPS

- The GVW must not exceed GVWR or GAWR as specified on the F.M. V.S.S./C.M.V.S.S. certification label.
- Do not load the front and rear axle to the GAWR. Doing so will exceed the GVWR.

WARNING

- Properly secure all cargo with ropes or straps to help prevent it from sliding or shifting. Do not place cargo higher than the seatbacks. In a sudden stop or collision, unsecured cargo could cause personal injury.
- Do not load your vehicle any heavier than the GVWR or the maximum front and rear GAWRs. If you do, parts of your vehicle can break, tire damage could occur, or it can change the way your vehicle handles. This could result in loss of control and cause personal injury.
- Overloading not only can shorten the life of your vehicle and the tire, but can cause unsafe vehicle handling and longer braking distances. This may cause a premature tire failure, which

could result in a serious accident and personal injury. Failures caused by overloading are not covered by the vehicle's warranty.

MEASUREMENT OF WEIGHTS

Secure loose items to prevent weight shifts that could affect the balance of your vehicle. When the vehicle is loaded, drive to a scale and weigh the front and the rear wheels separately to determine axle loads. Individual axle loads should not exceed either of the Gross Axle Weight Ratings (GAWR). The total of the axle loads should not exceed the Gross Vehicle Weight Rating (GVWR). These ratings are given on the vehicle certification label. If weight ratings are exceeded, move or remove items to bring all weights below the ratings.

TOWING A TRAILER (AWD models)



WARNING

Overloading or improper loading of a trailer and its cargo can adversely affect vehicle handling, braking and performance and may lead to accidents.



CAUTION

- **Do not tow a trailer or haul a heavy load for the first 500 miles (800 km). Your EV system, axle or other parts could be damaged.**
- **For the first 500 miles (800 km) that you tow a trailer, do not drive over 50 MPH (80 km/h) and do not make starts at full throttle. This helps the EV system and other parts of your vehicle wear in at the heavier loads.**

Your new vehicle was designed to be used primarily to carry passengers and cargo. Remember that towing a trailer places additional loads on your vehicle's EV system, drivetrain, steering, braking and other systems.

A NISSAN Towing Guide (U.S. only) is

available on the website at www.nissanusa.com. This guide includes information on trailer towing capability and the special equipment required for proper towing.

MAXIMUM LOAD LIMITS

Maximum trailer loads

Never allow the total trailer load to exceed the value specified in the "Towing load/specification" (P.10-17) chart found in this section. The total trailer load equals trailer weight plus its cargo weight.

The maximum Gross Combined Weight Rating (GCWR) should not exceed the value specified in the following "Towing Load/Specification" chart.

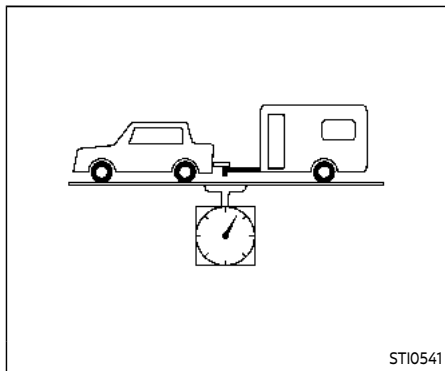

The GCWR equals the combined weight of the towing vehicle (including passengers and cargo) plus the total trailer load. Towing loads greater than these or using improper towing equipment could adversely affect vehicle handling, braking and performance.

The ability of your vehicle to tow a trailer is not only related to the maximum trailer loads, but also the places you plan to tow. Tow weights appropriate for level highway driving may have to be reduced for low traction situations (for example, on slippery boat ramps).

Temperature conditions can also affect towing. For example, towing a heavy

trailer in high outside temperatures on graded roads can affect motor and inverter performance and cause overheating. The motor and inverter protection mode, which helps reduce the chance of motor and inverter damage, could activate and automatically decrease driving force. Vehicle speed may decrease under high load. Plan your trip carefully to account for trailer and vehicle load, weather and road conditions.



WARNING

Overheating can result in reduced driving force and vehicle speed. The reduced speed may be lower than other traffic, which could increase the chance of a collision. Be especially careful when driving. If the vehicle cannot maintain a safe driving speed, pull to the side of the road in a safe area. Allow the motor to cool and return to normal operation.



CAUTION

Vehicle damage resulting from improper towing procedures is not covered by NISSAN warranties.

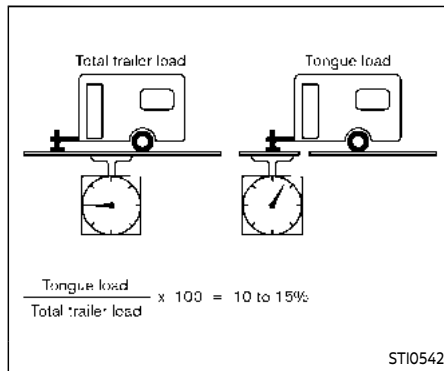

Tongue load

When using a weight carrying or a weight distributing hitch, keep the tongue load between 10 - 15% of the total trailer load or use the trailer tongue load specified by the trailer manufacturer. The tongue load must be within the maximum tongue load limits shown in the following "Towing Load/Specification" chart. If the tongue load becomes excessive, rearrange cargo to allow for proper tongue load.

$$\frac{\text{Tongue load}}{\text{Total trailer load}} \times 100 = 10 \text{ to } 15\%$$

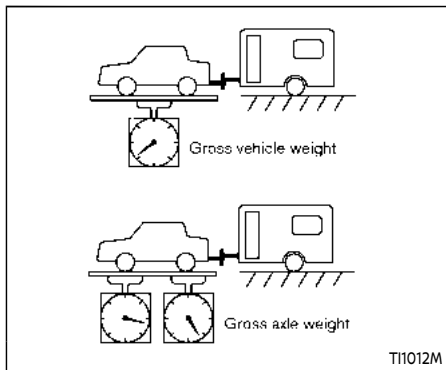

MAXIMUM GROSS VEHICLE WEIGHT (GVW)/MAXIMUM GROSS AXLE WEIGHT (GAW)

The GVW of the towing vehicle must not exceed the Gross Vehicle Weight Rating (GVWR) shown on the F.M.V.S.S./C.M.V.S.S. certification label. The GVW equals the combined weight of the unloaded vehicle, passengers, luggage, hitch, trailer tongue load and any other optional equipment. In addition, front or rear GAW must not exceed the Gross Axle Weight Rating (GAWR) shown on the F.M.V.S.S./C.M.V.S.S. certification label.

Towing capacities are calculated assuming a base vehicle with driver and any

options required to achieve the rating. Additional passengers, cargo and/or optional equipment, such as the trailer hitch, will add weight to the vehicle and reduce your vehicle's maximum towing capacity and trailer tongue load.

The vehicle and trailer need to be weighed to confirm the vehicle is within the GVWR, Front GAWR, Rear GAWR, Gross Combined Weight Rating (GCWR) and Towing capacity.

All vehicle and trailer weights can be measured using platform type scales commonly found at truck stops, highway weigh stations, building supply centers or salvage yards.

To determine the available payload capacity for tongue/king pin load, use the following procedure.

1. Locate the GVWR on the F.M.V.S.S./C.M.V.S.S. certification label.
2. Weigh your vehicle on the scale with all of the passengers and cargo that are normally in the vehicle when towing a trailer.
3. Subtract the actual vehicle weight from the GVWR. The remaining amount is the available maximum tongue/king pin load.

To determine the available towing capacity, use the following procedure.

1. Find the GCWR for your vehicle on the "Towing Load/Specification" chart found later in this section.
2. Subtract the actual vehicle weight from the GCWR. The remaining amount is the available maximum towing capacity.

To determine the Gross Trailer Weight, weigh your trailer on a scale with all equipment and cargo, that are normally in the trailer when it is towed. Make sure the Gross trailer weight is not more than the Gross Trailer Weight Rating shown on the trailer and is not more than the calculated available maximum towing capacity.

Also weigh the front and rear axles on the scale to make sure the Front Gross Axle Weight and Rear Gross Axle Weight are not more than Front Gross Axle Weight and Rear Gross Axle Weight on the F.M.V.S.S./C.M.V.S.S. certification label. The cargo in the trailer and vehicle may need to be moved or removed to meet the specified ratings.

Example:

- Gross Vehicle Weight (GVW) as weighed on a scale - including passengers, cargo and hitch - 6,350 lb. (2,880 kg).

- Gross Vehicle Weight Rating (GVWR) from F.M.V.S.S./C.M.V.S.S. certification label - 7,250 lb. (3,289 kg).
- Gross Combined Weight Rating (GCWR) from "Towing Load/Specification" chart - 15,100 lb. (6,849 kg).
- Maximum Trailer towing capacity from "Towing Load/Specification" chart - 9,100 lb (4,128 kg).

7,250 lb. (3,289 kg)	GVWR
- 6,350lb. (2,880 kg)	GVW
= 900 lb. (409 kg)	
	Available for tongue weight

15,100 lb. (6,849 kg)	GCWR
- 6,350 lb. (2,880 kg)	GVW
= 8,750 lb. (3,969 kg)	
	Capacity available for towing

900 lb. (409 kg) /	Available tongue weight
8,750 lb. (3,969 kg)	Available capacity
= 10 % tongue weight	

The available towing capacity may be less than the maximum towing capacity due to the passenger and cargo load in the vehicle.

Remember to keep trailer tongue weight between 10 - 15% of the trailer weight or within the trailer tongue load specifica-

tion recommended by the trailer manufacturer. If the tongue load becomes excessive, rearrange the cargo to obtain the proper tongue load. Do not exceed the maximum tongue weight specification shown in the "Towing load/specification" chart even if the calculated available tongue weight is greater than 15%. If the calculated tongue weight is less than 10%, reduce the total trailer weight to match the available tongue weight.

Always verify that available capacities are within the required ratings.

TOWING LOAD/SPECIFICATION



WARNING

The towing capacities provided in this manual are for general reference only. The safe towing capacity of your vehicle is affected by dealer and factory installed options and passenger and cargo loads. You must weigh the vehicle and trailer as described in this manual to determine the actual vehicle towing capacity. Do not exceed the published maximum towing capacity, or the GCWR or the GVWR shown on the F.M.V.S.S./C.M.V.S.S. certification label. Doing so can result in an accident causing serious personal injury or property damage.

Towing load/specification chart		
Axle Type	All-Wheel Drive (AWD)	
Maximum Towing Capacity*1	1,500 lbs (680 kg)	
Maximum Tongue Load	150 lbs (68 kg)	
Maximum Gross Combined Weight Rating	7,088 lbs (3,215 kg) (models with 66 kWh battery)	7,430 lbs (3,370 kg) (models with 91 kWh battery)

- 1: The towing capacity values are calculated assuming a base vehicle with driver and any options required to achieve the rating. Additional passengers, cargo and/or optional equipment will add weight to the vehicle and reduce your vehicle's maximum towing capacity.

TOWING SAFETY

Trailer hitch

Choose a proper hitch for your vehicle and trailer. Make sure the trailer hitch is securely attached to the vehicle to help avoid personal injury or property damage due to sway caused by crosswinds, rough road surfaces or passing trucks.



WARNING

Trailer hitch components have specific weight ratings. Your vehicle may be capable of towing a trailer heavier than the weight rating of the hitch components. Never exceed the weight rating of the hitch components. Doing so can cause serious personal injury or property damage.

Hitch ball

Choose a hitch ball of the proper size and weight rating for your trailer:

- The required hitch ball size is stamped on most trailer couplers. Most hitch balls also have the size printed on top of the ball.
- Choose the proper class hitch ball based on the trailer weight.

- The diameter of the threaded shank of the hitch ball must be matched to the ball mount hole diameter. The hitch ball shank should be no more than 1/16' smaller than the hole in the ball mount.
- The threaded shank of the hitch ball must be long enough to be properly secured to the ball mount. There should be at least 2 threads showing beyond the lock washer and nut.

Ball mount

The hitch ball is attached to the ball mount and the ball mount is inserted into the hitch receiver. Choose a proper class ball mount based on the trailer weight. Additionally, the ball mount should be chosen to keep the trailer tongue level with the ground.

Weight carrying hitches

A weight carrying or “dead weight” ball mount is one that is designed to carry the whole amount of tongue weight and gross weight directly on the ball mount and on the receiver.

Weight distribution hitch

This type of hitch is also called a “load-leveling” or “equalizing” hitch. A set of bars attach to the ball mount and to the trailer to distribute the tongue weight (hitch weight) of your trailer. Many vehicles cannot carry the full tongue weight of a given trailer, and need some of the tongue weight transferred through the frame and pushing down on the front wheels. This gives stability to the tow vehicle.

A weight-distributing hitch system (Class IV) is recommended if you plan to tow trailers with a maximum weight over 5,000 lbs (2,267 kg). Check with the trailer and towing equipment manufacturers to determine if they recommend the use of a weight-distributing hitch system.

NOTE:

A weight-distributing hitch system may affect the operation of trailer surge brakes. If you are considering use of a weight-distributing hitch system with a surge brake-equipped trailer, check with the surge brake, hitch or trailer manufacturer to determine if and how this can be done.

Follow the instructions provided by the manufacturer for installing and using the weight-distributing hitch system.

General set-up instructions are as follows:

1. Park unloaded vehicle on a level surface. With the power switch in the ON position and the doors closed, allow the vehicle to stand for several minutes so that it can level.
2. Measure the height of a reference point on the front and rear bumpers at the center of the vehicle.
3. Attach the trailer to the vehicle and adjust the hitch equalizers so that the front bumper height is within 0 - .5 inches (0 - 13 mm) of the reference height measured in step 2. The rear bumper should be no higher than the reference height measured in step 2.



WARNING

Properly adjust the weight distributing hitch so the rear of the bumper is no higher than the measured reference height when the trailer is attached. If the rear bumper is higher than the measured reference height when loaded, the vehicle may handle unpredictably which could cause a loss of vehicle control and cause serious personal injury or property damage.

Sway control device

Sudden maneuvers, wind gusts and buffeting caused by other vehicles can affect trailer handling. Sway control devices may be used to help control these affects. If you choose to use one, contact a reputable trailer hitch supplier to make sure the sway control device will work with the vehicle, hitch, trailer and the trailer's brake system. Follow the instructions provided by the manufacturer for installing and using the sway control device.

Class I hitch

Class I trailer hitch equipment (receiver, ball mount and hitch ball) can be used to tow trailers of a maximum weight of 2,000 lb (907 kg).

Tire pressures

- When towing a trailer, inflate the vehicle tires to the recommended cold tire pressure indicated on the Tire and Loading Information label.
- Trailer tire condition, size, load rating and proper inflation pressure should be in accordance with the trailer and tire manufacturers' specifications.

Safety chains

Always use a suitable chain between your vehicle and the trailer. The safety chains should be crossed and should be attached to the hitch, not to the vehicle bumper or axle. Be sure to leave enough slack in the chains to permit turning corners.

Trailer lights (if so equipped)



CAUTION

When splicing into the vehicle electrical system, a commercially available power-type module/converter must be used to provide power for all trailer lighting. This unit uses the vehicle battery as a direct power source for all trailer lights while using the vehicle tail light, stoplight and turn signal circuits as a signal source. The module/converter must draw no more than 15 milliamps from the stop and tail lamp circuits. Using a module/converter that exceeds these power requirements may damage the vehicle's electrical system. See a reputable trailer retailer to obtain the proper equipment and to have it installed.

Trailer lights should comply with federal and/or local regulations. For assistance in hooking up trailer lights, contact a NISSAN certified ARIYA dealer or reputable trailer retailer.

Pre-towing tips

- Be certain your vehicle maintains a level position when a loaded or unloaded trailer is hitched. Do not drive the vehicle if it has an abnormal nose-up or nose-down condition; check for improper tongue load, overload, worn suspension or other possible causes of either condition.
- Always secure items in the trailer to prevent load shift while driving.
- Keep the cargo load as low as possible in the trailer to keep the trailer center of gravity low.
- Load the trailer so approximately 60% of the trailer load is in the front half and 40% is in the back half. Also make sure the load is balanced side to side.
- Check your hitch, trailer tire pressure, vehicle tire pressure, trailer light operation, and trailer wheel lug nuts every time you attach a trailer to the vehicle.
- Be certain your rearview mirrors conform to all federal, state or local regulations. If not, install any mirrors

required for towing before driving the vehicle.

- Determine the overall height of the vehicle and trailer so the required clearance is known.

Trailer towing tips

In order to gain skill and an understanding of the vehicle's behavior, you should practice turning, stopping and backing up in an area which is free from traffic. Steering stability, and braking performance will be somewhat different than under normal driving conditions.

- Always secure items in the trailer to prevent load shift while driving.
- Lock the trailer hitch coupler with a pin or lock to prevent the coupler from inadvertently becoming unlatched.
- Avoid abrupt starts, acceleration or stops.
- Avoid sharp turns or lane changes.
- Always drive your vehicle at a moderate speed. Some states or provinces have specific speed limits for vehicles that are towing trailers. Obey the local speed limits.
- When backing up, hold the bottom of the steering wheel with one hand. Move your hand in the direction in which you want the trailer to go. Make small corrections and back up slowly.

If possible, have someone guide you when you are backing up.

Always block the wheels on both vehicle and trailer when parking. Parking on a slope is not recommended; however, if you must do so:



CAUTION

If you push the park button to engage the P (Park) position before blocking the wheels and applying the parking brake, transmission damage could occur.

1. Apply and hold the brake pedal.
 2. Have someone place blocks on the downhill side of the vehicle and trailer wheels.
 3. After the wheel blocks are in place, slowly release the brake pedal until the blocks absorb the vehicle load.
 4. Apply the parking brake.
 5. Push the park button to engage the P (Park) position.
 6. Turn off the EV system.
- To drive away:
1. Apply and hold the brake pedal.

2. Start the EV system.
 3. Shift the transmission into gear.
 4. Release the parking brake.
 5. Drive slowly until the vehicle and trailer are clear from the blocks.
 6. Apply and hold the brake pedal.
 7. Have someone retrieve and store the blocks.
- While going downhill, the weight of the trailer pushing on the tow vehicle may decrease overall stability. Therefore, to maintain adequate control, reduce your speed and shift to a lower gear. Avoid long or repeated use of the brakes when descending a hill, as this reduces their effectiveness and could cause overheating. Shifting to a lower gear instead provides “engine braking” and reduces the need to brake as frequently.
 - Trailer towing requires more energy than normal circumstances.
 - Avoid towing a trailer for your vehicle’s first 500 miles (800 km).
 - For the first 500 miles (800 km) that you do tow, do not drive over 50 MPH (80 km/h).
 - Have your vehicle serviced more often than at intervals specified in the recommended maintenance schedule shown in the “9. Maintenance and

schedules” section.

- When making a turn, your trailer wheels will be closer to the inside of the turn than your vehicle wheels. To compensate for this, make a larger than normal turning radius during the turn.
- Crosswinds and rough roads will adversely affect vehicle/trailer handling, possibly causing vehicle sway. When being passed by larger vehicles, be prepared for possible changes in crosswinds that could affect vehicle handling.

Do the following if the trailer begins to sway:

1. Take your foot off the accelerator pedal to allow the vehicle to coast and steer as straight ahead as the road conditions allow. This combination will help stabilize the vehicle.
 - Do not correct trailer sway by steering or applying the brakes.
 2. When the trailer sway stops, gently apply the brakes and pull to the side of the road in a safe area.
 3. Try to rearrange the trailer load so it is balanced as described earlier in this section.
- Be careful when passing other vehicles. Passing while towing a trailer

requires considerably more distance than normal passing. Remember the length of the trailer must also pass the other vehicle before you can safely change lanes.

- Use the B position for downhill driving. When the B position is used, more regenerative brake is applied when the accelerator pedal is released in comparison to the D (Drive) position. Less deceleration is provided by the regenerative brake system when the Li-ion battery is fully charged or the battery temperature is low.
- Avoid holding the brake pedal down too long or too frequently. This could cause the brakes to overheat, resulting in reduced braking efficiency.
- Increase your following distance to allow for greater stopping distances while towing a trailer. Anticipate stops and brake gradually.
- NISSAN recommends that the cruise control not be used while towing a trailer.
- While towing a trailer, do not use the following systems (if so equipped):
 - e-Step system
 - Lane Departure Warning (LDW) system

- Intelligent Lane Intervention (I-LI) system
- Blind Spot Warning (BSW) system
- Intelligent Blind Spot Intervention (I-BSI) system
- Rear Cross Traffic Alert (RCTA) system
- ProPILOT Assist system (Intelligent Cruise Control (ICC), ProPILOT Assist with Navi-link, ProPILOT Assist 2.0 and Steering Assist)
- Automatic Emergency Braking (AEB) with Pedestrian Detection system
- Intelligent Forward Collision Warning (I-FCW) system
- Rear Automatic Braking (RAB) system
- Some states or provinces have specific regulations and speed limits for vehicles that are towing trailers. Obey the local speed limits.
- Check your hitch, trailer wiring harness connections, and trailer wheel lug nuts after 50 miles (80 km) of travel and at every break.
- When launching a boat, do not allow the water level to go over the rear bumper.
- Make sure you disconnect the trailer lights before backing the trailer into

the water or the trailer lights may burn out.

FLAT TOWING

Towing your vehicle with all four wheels on the ground is sometimes called flat towing. This method is typically used when towing a vehicle behind a recreational vehicle, such as a motor home.



CAUTION

- Failure to follow these guidelines can result in severe reduction gear damage.
- DO NOT tow this vehicle with all four wheels on the ground (flat towing).
- For emergency towing procedures see "Towing your vehicle" (P. 6-13).

NOTE:

If the Li-ion battery becomes completely discharged:

- The vehicle is automatically placed in the ON position and it will not be possible to switch to the READY to drive position.
- The vehicle is automatically switched to the N (Neutral) position and it will not be possible to drive the vehicle.

UNIFORM TIRE QUALITY GRADING

For additional information, see “If the Li-ion battery becomes completely discharged” (P.6-18).

DOT (Department Of Transportation) Quality Grades: All passenger car tires must conform to federal safety requirements in addition to these grades.

Quality grades can be found where applicable on the tire sidewall between tread shoulder and maximum section width. For example:

Treadwear 200 Traction AA Temperature A

TREADWEAR

The treadwear grade is a comparative rating based on the wear rate of the tire when tested under controlled conditions on a specified government test course. For example, a tire graded 150 would wear one and one-half

(1 1/2) times as well on the government course as a tire graded 100. The relative performance of tires depends upon actual conditions of their use, however, and may depart significantly from the norm due to variations in driving habits, service practices and differences in road characteristics and climate.

TRACTION AA, A, B AND C

The traction grades, from highest to lowest, are AA, A, B and C. Those grades represent the tire's ability to stop on wet pavement as measured under controlled conditions on specified government test surfaces of asphalt and concrete. A tire marked C may have poor traction performance.



WARNING

The traction grade assigned to this tire is based on straight-ahead braking traction tests, and does not include acceleration, cornering, hydroplaning, or peak traction characteristics.

TEMPERATURE A, B AND C

The temperature grades are A (the highest), B, and C, representing the tire's resistance to the generation of heat and its ability to dissipate heat when tested under controlled conditions on a specified indoor laboratory test wheel. Sustained high temperature can cause the material of the tire to degenerate and reduce tire life, and excessive temperature can lead to sudden tire failure. The grade C corresponds to a level of perfor-

mance which all passenger car tires must meet under the Federal Motor Vehicle Safety Standard No. 109. Grades B and A represent higher levels of performance on the laboratory test wheel than the minimum required by law.



WARNING

The temperature grade for this tire is established for a tire that is properly inflated and not overloaded. Excessive speed, under-inflation, or excessive loading, either separately or in combination, can cause heat build-up and possible tire failure.

REPORTING SAFETY DEFECTS

For USA

If you believe that your vehicle has a defect which could cause a crash or could cause injury or death, you should immediately inform the National Highway Traffic Safety Administration (NHTSA) in addition to notifying NISSAN.

If NHTSA receives similar complaints, it may open an investigation, and if it finds that a safety defect exists in a group of vehicles, it may order a recall and remedy campaign. However, NHTSA cannot become involved in individual problems between you, your dealer, or NISSAN.

To contact NHTSA, you may call the Vehicle Safety Hotline toll-free at 1-888- 327-4236 (TTY: 1-800-424-9153); go to <http://www.safercar.gov>; or write to: Administrator, NHTSA, 400 Seventh Street, SW., Washington, D.C. 20590. You can also obtain other information about motor vehicle safety from <http://www.safercar.gov>.

You may notify NISSAN by contacting our Consumer Affairs Department, toll-free, at 1-800-NISSAN-1.

For Canada

If you believe that your vehicle has a defect which could cause a crash or could cause injury or death, you should immediately inform Transport Canada in addition to notifying NISSAN.

If Transport Canada receives complaints, it may open an investigation, and if it finds that a safety defect exists in a group of vehicles, it may request that NISSAN conduct a recall campaign. However, Transport Canada cannot become involved in individual problems between you, your dealer, or NISSAN.

You may contact Transport Canada's Defect Investigations and Recalls Division toll free at 1-800-333-0510. You may also report safety defects online at: <https://wwwapps.tc.gc.ca/Saf-Sec-Sur/7/PCDB-BDPP/fc-cp.aspx?lang=eng> (English speakers) or <https://>

EVENT DATA RECORDERS (EDR)

wwwapps.tc.gc.ca/Saf-Sec-Sur/7/PCDB-BDPP/fc-cp.aspx?lang=fra (French speakers).

Additional information concerning motor vehicle safety may be obtained from Transport Canada's Road Safety Information Centre at 1-800-333-0371 or online at www.tc.gc.ca/roadsafety (English speakers) or www.tc.gc.ca/securiteroutiere (French speakers).

To notify NISSAN of any safety concerns please contact our Consumer Information Centre toll free at 1-800-387-0122.

This vehicle is equipped with an Event Data Recorder (EDR). The main purpose of an EDR is to record, in certain crash or near crash-like situations, such as an air bag deployment or hitting a road obstacle, data that will assist in understanding how a vehicle's systems performed. The EDR is designed to record data related to vehicle dynamics and safety systems for a short period of time, typically 30 seconds or less. The EDR in this vehicle is designed to record such data as:

- How various systems in your vehicle were operating;
- Whether or not the driver and passenger safety belts were buckled/fastened;
- How far (if at all) the driver was depressing the accelerator and/or brake pedal; and,
- How fast the vehicle was traveling.
- Sounds are not recorded.

These data can help provide a better understanding of the circumstances in which crashes and injuries occur.

NOTE: EDR data are recorded by your vehicle only if a nontrivial crash situation occurs; no data are recorded by the EDR under normal driving conditions and no personal data (e.g. name, gender, age and crash location) are recorded. However, other parties, such as law enforcement,

could combine the EDR data with the type of personally identifying data routinely acquired during a crash investigation.

To read data recorded by an EDR, special equipment is required and access to the vehicle or the EDR is needed. In addition to the vehicle manufacturer and NISSAN certified ARIYA dealer, other parties, such as law enforcement, that have the special equipment, can read the information if they have access to the vehicle or the EDR. EDR data will only be accessed with the consent of the vehicle owner or lessee or as otherwise required or permitted by law.

ADDITIONAL DATA RECORDING

If your vehicle is equipped with one of the optional ProPILOT Assist systems, it will also be equipped with supplemental data recording functionality intended to assist in understanding how ProPILOT Assist performs in certain nontrivial crash or near-crash scenarios. The ProPILOT Assist systems do not record conversations, sounds, or images of inside of the vehicle.

Supplemental recording is designed to capture items such as the following:

For ProPILOT Assist

- Driver operational status of the accelerator, brakes, steering, etc.

- Detection status of a vehicle ahead and lane markers
- Vehicle information including distance to vehicle ahead and lateral position
- Information on the operation of the ProPILOT Assist and other crash avoidance features
- ProPILOT Assist malfunction diagnosis information
- External images from the multi-sensing front camera (Available only when the SRS air bag or AEB with Pedestrian Detection system is activated)

For ProPILOT Assist 2.0

- Driver operational status of the accelerator, brakes, steering, etc.
- Detection status of direction of the driver's face and opening/closing of the driver's eyelids
- Information on the operation of the ProPILOT Assist 2.0 and other crash avoidance features
- Detection status of a vehicle ahead and lateral position, lane markers and road structure
- Vehicle information including the vehicle speed, the vehicle position (from GNSS), etc
- External images from the multi-sensing front camera (Available only

when the SRS air bag or AEB with Pedestrian Detection system is activated)

To read this supplemental data, special equipment is required. This supplemental data will only be accessed pursuant to the terms and conditions you acknowledge during the enrollment process or through the vehicle's head unit, or as otherwise required or permitted by law. If downloaded, NISSAN and third party vendors entrusted by NISSAN may use the data recorded for the purpose of improving NISSAN's vehicle safety performance.

NISSAN and third party vendors entrusted by NISSAN will not disclose/provide the recorded data to another third party except:

- With the consent of the vehicle owner or with the consent of the lessee
- In response to an official request from law enforcement, court order, governmental agency, or other legally enforceable request
- For research purposes after the data is modified such that it is no longer tied to a specific vehicle or vehicle owner (anonymized)
- For use as part of NISSAN's defense in litigation.

In the USA: Data collected could vary based on applicable law. If you have any

questions regarding the data NISSAN may collect or disclose about you, please consult the Terms and Conditions of the applicable program and visit our Privacy Policy at <https://www.nissanusa.com/privacy.html>

NISSAN SOFTWARE LICENSE

See "Foreword".

OWNER'S MANUAL/SERVICE MANUAL ORDER INFORMATION

Genuine NISSAN Service Manuals for this model year and prior can be purchased. A genuine NISSAN Service Manual is the best source of service and repair information for your vehicle. This manual is the same one used by the factory trained technicians working at a NISSAN certified ARIYA dealer. Genuine NISSAN Owner's Manuals can also be purchased.

In the USA:

For current pricing and availability of genuine **NISSAN Service Manuals** contact:

www.nissan-techinfo.com

For current pricing and availability of genuine **NISSAN Owner's Manuals** contact:

1-800-247-5321

In Canada:

To purchase a copy of a genuine NISSAN Service Manual or Owner's Manual for this model year and prior please contact a NISSAN certified ARIYA dealer. For the phone number and location of a NISSAN certified ARIYA dealer in your area call the NISSAN Information Center at 1-800-387-0122 and a bilingual NISSAN representative will assist you.

MEMO

11 Index

A

ABS (Anti-lock Braking System)	5-153
Active sound enhancement	5-175
Adjustable luggage floor	2-83
Advanced Air Bag System	1-54
Air bag system	
Advanced Air Bag System	1-54
Driver and front passenger supplemental knee air bag system	1-63
Front and rear seat-mounted side-impact supplemental air bag system	1-65
Front central seat-mounted side-impact supplemental air bag system	1-65
Front passenger air bag and status light	1-56
Roof-mounted curtain side-impact supplemental air bag system	1-65
Air bag warning labels	1-68
Air bag warning light	1-69, 2-15
Air conditioner	
Air conditioner operation	4-28
Air conditioner service	4-37
Air conditioner specification label	10-7
Air conditioning system refrigerant and lubricant recommendations	4-37
Air conditioner settings	4-33
Alarm, How to stop alarm (see vehicle security system)	2-55
Alcohol, drugs and driving	5-10
Alert	
Rear Door Alert	2-75

All-Wheel Drive (AWD) (See All-Wheel Drive (AWD) system)	5-149
All-Wheel Drive (AWD) system	5-149
Android Auto	4-2
Anti-lock Braking System (ABS)	5-153
Anti-lock Braking System (ABS) warning light	2-15
Appearance care	
Exterior appearance care	7-2
Interior appearance care	7-4
Apple CarPlay	4-2
Approach unlock function	3-11
Approaching Vehicle Sound for Pedestrians (VSP) system	EV-20
Armrest	1-9
Attention to the road	5-112
Audible reminders	2-21
Automatic	
Door locks	3-5
Automatic air conditioner and heater	4-29
Automatic brake hold	5-26
Automatic Emergency Braking (AEB) system OFF warning light	2-16
Automatic Emergency Braking (AEB) with Pedestrian Detection	5-120
Automatic moonroof and sunshade	2-95
Average energy consumption	2-45
Average speed	2-45
Avoiding collision and rollover	5-9
AWD (See All-Wheel Drive (AWD) system)	5-149

B

Battery	
12-volt battery	8-11

Battery replacement, Intelligent Key	8-13
Battery saver system	2-66
Li-ion battery	EV-2
Before starting the EV (Electric Vehicle) system	5-16
Before using emergency tire puncture repair kit	6-6
Blind Spot Warning (BSW)	5-55
Blocking wheels	6-11
Booster seats	1-44
Brake	
Anti-lock Braking System (ABS)	5-153
Brake fluid	8-7
Brake system	5-152
Brake system warning light (yellow)	2-16
Brakes	8-9
Parking brake	5-24
Warning light	2-13
Brake system warning light (yellow)	2-16
Brightness control	
Instrument panel	2-10
Bulb check/instrument panel	2-12
Bulb replacement	8-16

C

Card holder	2-88
Cargo cover	2-89
Cargo light	2-99
Charge port light	3-28
Charger	
USB (Universal Serial Bus) charging connector	2-77
Wireless charger	2-78
Charging	
Charge port lid	3-27

Charging methods.....	CH-35
Charging related indicator lights.....	CH-38
Charging status indicator light.....	CH-38
Charging timer.....	CH-35
Charging troubleshooting guide.....	CH-41
How to quick charge.....	CH-30
Immediate charge.....	CH-37
Precautions on charging.....	CH-2
Specifications.....	10-4
Charging status display.....	2-48
Chassis control.....	5-158
Checking	
Checking coolant level.....	8-6
Child restraints.....	1-26
Booster seats.....	1-44
LATCH system.....	1-28
Precautions on child restraints.....	1-26
Child safety.....	1-23
Child safety rear door lock.....	3-6
Chimes	
Seat belt warning light and chime.....	1-17, 2-14
Chimes, Audible reminders.....	2-21
Cleaning exterior and interior.....	7-2, 7-4
Climate control	
Climate Ctrl. Timer.....	4-35
Clock.....	2-51
Coat hook.....	2-88
Cold weather driving.....	5-173
Connection to Roadside Assistance.....	6-2
Console box.....	2-85
Power sliding function.....	2-85
Conventional (fixed speed) cruise control.....	5-102
Coolant	
Changing coolant.....	8-6
Checking coolant level.....	8-6

Recommended fluids/lubricants and capacities.....	10-2
Cooling system.....	8-4
Corrosion protection.....	7-7
Cover, Cargo cover.....	2-89
Cruise control	
Conventional (fixed speed) cruise control.....	5-102
Cup holders.....	2-82

D

Daytime Running Lights (DRL) system.....	2-67
Defroster switch, Rear window and outside mirror defroster switch.....	2-60
Dimensions and weights.....	10-5
Display	
Head Up Display (HUD).....	2-51
Vehicle information display.....	2-22
Drive Computer.....	2-45
Drive Mode Selector.....	5-29
Driver and front passenger supplemental knee air bag.....	1-63
Driver Assistance systems.....	5-32
Common troubleshooting guide.....	5-36
Driver Monitor.....	5-111
Driving	
All-Wheel Drive (AWD) system.....	5-149
Cold weather driving.....	5-173
Drive Mode Selector.....	5-29
Driving vehicle.....	5-17
On-pavement and off-road driving.....	5-9
Precautions when starting and driving.....	5-5
Safety precautions.....	5-11
Driving range.....	2-9

Driving vehicle.....	5-17
----------------------	------

E

e-Step indicator.....	2-10
e-Step system.....	5-21
Easy-Fill Tire Alert system.....	5-8
ECO Drive Report.....	2-49
ECO mode.....	5-30
Efficient use of your vehicle.....	EV-16
Elapsed time.....	2-45
Electric power steering.....	5-151
Electric power steering warning light.....	2-17
Electric shift control system warning light.....	2-13
Emblem light.....	2-69
Emergency Braking	
Automatic Emergency Braking (AEB) with Pedestrian Detection.....	5-120
Emergency Call (SOS) button.....	2-80
Emergency shut-off system.....	EV-8
Emergency tire puncture repair kit.....	6-4, 8-30
Entry/exit function.....	3-29
EV Characteristics.....	EV-9
EV system.....	EV-2
Emergency EV system shut off.....	5-15, 6-3
Push Brake and Start Button to Drive indicator.....	2-34
EV system warning light.....	2-17
EV unique information.....	EV-18
Event Data Recorders (EDR).....	10-25
EVSE (Electric Vehicle Supply Equipment) Control box indicator light.....	CH-39
Explanation of scheduled maintenance items.....	9-5

F

F.M.V.S.S./C.M.V.S.S. certification label.....	10-7
Flashers (See hazard warning flasher switch).....	6-2
Flat tire.....	6-3
Flat towing.....	10-22
Flexible center storage.....	2-86
Floor mat cleaning.....	7-5
Fluid	
Brake fluid.....	8-7
Coolant.....	8-4
Recommended fluids/lubricants and capacities.....	10-2
Reduction gear fluid.....	8-6
Window washer fluid.....	8-10
Fog light switch.....	2-69
Forward Driving Aids.....	5-32
Front fog light switch.....	2-69
Front manual seat adjustment.....	1-4
Front passenger air bag and status light.....	1-56
Front seat, Front seat adjustment.....	1-4
Fuses.....	8-15

G

Garage door opener	
HomeLink® Universal Transceiver.....	2-99
Garage mode system.....	3-25
Gauge.....	2-5
Odometer.....	2-7
Speedometer.....	2-7
General maintenance.....	9-2
Glove box.....	2-84

H

Hands On Detection.....	5-109
Hazard warning flasher switch.....	6-2
Head restraints/headrests.....	1-10
Head Up Display (HUD).....	2-51
Headlight aiming control.....	2-67
Headlights	
Bulb replacement.....	8-17
Headlight switch.....	2-61
Heated seats.....	2-70
Heated steering wheel.....	2-70
Heater	
Heater and air conditioner operation.....	4-28
High beam assist.....	2-64
High voltage precautions.....	EV-6
Hill start assist system.....	5-159
HomeLink® Universal Transceiver.....	2-99
Hood release.....	3-20
Hook	
Coat hook.....	2-88
Luggage hook.....	2-90
Horn.....	2-69
How to quick charge.....	CH-30

I

If the Li-ion battery becomes completely discharged.....	6-18
Immediate charge.....	CH-37
Immobilizer system.....	2-55
Indicator	
Lights.....	2-15
Vehicle information display.....	2-22

indicator light

Electronic parking brake warning light.....	2-14
Inside mirror.....	3-31
Installing tire.....	6-13
Instrument brightness control.....	2-10
Intelligent Around View® Monitor.....	4-11
Intelligent Auto Headlight system.....	2-62
Intelligent Blind Spot Intervention (I-BSI).....	5-63
Intelligent Cruise Control (ICC).....	5-98
Intelligent Driver Alertness (I-DA).....	5-139
Intelligent Forward Collision Warning (I-FCW).....	5-130
Intelligent Key button operation light.....	3-18
Intelligent Key system.....	3-6, 5-13
Key operating range.....	3-8
Key operation.....	3-9
Remote keyless operation.....	3-15
Intelligent Lane Intervention (I-LI).....	5-49
Intelligent Rear View Mirror.....	3-32
Intelligent Trace Control.....	5-158
Interior light replacement.....	8-17
Interior light switch.....	2-98
Interior lights.....	2-97
ISOFIX child restraint.....	1-28

J

Jacking up vehicle.....	6-10
Jump starting.....	6-15

K

Key	
Power switch positions.....	5-14

Keyless entry	
With Intelligent Key system	
(See Intelligent Key system)	3-15
Keys	3-2
For Intelligent Key system	3-6

L

Labels	
Air bag warning labels	1-68
Air conditioner specification label	10-7
F.M.V.S.S./C.M.V.S.S.	
certification label	10-7
Motor serial number	10-6
Tire and Loading	
information label	8-20, 10-7
Vehicle identification number (VIN)	10-6
Lane Change Assist	5-113
Lane Departure Warning (LDW)	5-44
LATCH system	1-28
Li-ion battery	EV-2
Li-ion battery cooler	EV-5
Li-ion battery temperature	
control system	EV-5
Li-ion battery warmer	EV-5
Li-ion battery available charge gauge	2-8
License plate, installing front	
license plate	10-9
Liftgate	3-21
Auto closure	3-26
Liftgate release lever	3-26
Operating manual liftgate	3-21
Operating power liftgate	3-22
Light	
Air bag warning light	1-69
Bulb replacement	8-16
Cargo light	2-99

Fog light switch	2-69
Headlight switch	2-61
Headlights bulb replacement	8-17
Indicator lights	2-15
Interior lights	2-97
Map lights	2-98
Rear personal lights	2-98
Vanity mirror lights	2-99
Warning lights, indicator lights and	
audible reminders	2-12
Lights, Exterior and interior	
light replacement	8-17
Lithium ion (Li-ion) battery	EV-2
Loading information (See vehicle	
loading information)	10-9
Lock	
Automatic door locks	3-5
Door locks	3-4
Power door lock	3-4
Low battery charge warning light	2-17
Low tire pressure warning light	2-17
Low tire pressure warning system	
(See Tire Pressure Monitoring	
System (TPMS))	5-5
Luggage	
Adjustable luggage floor	2-83
Luggage hooks	2-90

M

Maintenance	
12-volt battery	8-11
General maintenance	9-2
Maintenance precautions	8-2
Maintenance requirements	9-2
Maintenance schedules	9-6
Seat belt maintenance	1-22

Maintenance schedules	9-6
Manual front seat adjustment	1-4
Map lights	2-98
Master warning light	2-14, 2-19
Mechanical key (Intelligent Key system)	3-3
Memory seat	3-41
Meters and gauges	2-5
Instrument brightness control	2-10
Mirror	
Inside mirror	3-31
Intelligent Rear View Mirror	3-32
Outside mirrors	3-38
Vanity mirror	3-41
Moonroof	2-95
Motor	5-17, 10-5
Motor compartment	8-4
Moving Object Detection (MOD)	4-23

N

NISSAN SOFTWARE LICENSE	10-27
NISSAN Vehicle Immobilizer System	2-55

O

Odometer	2-7
Off-road recovery	5-9
Oil	
Recommended fluids/lubricants	
and capacities	10-2
Other lights	2-20
Outside air temperature	2-51
Outside mirrors	3-38
Owner's Manual/Service Manual	
order information	10-27

P

Panic alarm.....	3-17
Parking	
Parking brake.....	5-24
Parking on hills.....	5-150
Parking Aids.....	5-32
Parking brake	
Electronic parking brake	
warning light.....	2-14
Parking sensor	
ProPILOT Park.....	5-165
Passing Assist.....	5-115
Personal Display.....	2-24
Power	
Electric power steering.....	5-151
Power door lock.....	3-4
Power outlet.....	2-77
Power windows.....	2-91
Power economy.....	5-148
Power meter.....	2-7
Power switch.....	5-13
Power switch positions.....	5-14
Precautions	
Braking precautions.....	5-152
Charging.....	CH-2
Child restraints.....	1-26
Driving safety.....	5-11
High voltage precautions.....	EV-6
Maintenance.....	8-2
On-pavement and off-road driving.....	5-9
Road accident precautions.....	EV-8
Seat belt usage.....	1-14
SRS.....	1-48
When starting and driving.....	5-5

Preparing tools.....	6-10
ProPILOT	
ProPILOT Park.....	5-165
ProPILOT Assist Systems.....	5-82
ProPILOT Assist Systems limitations.....	5-88
ProPILOT Park.....	5-165
Push starting.....	6-19
Push-button power switch.....	5-13

R

RAB system.....	5-141
Radio antenna.....	4-38
Rapid air pressure loss.....	5-10
Rear Automatic Braking (RAB).....	5-141
Rear Automatic Braking (RAB) system	
OFF warning light.....	2-19
Rear Cross Traffic Alert (RCTA).....	5-75
Rear Door Alert.....	2-75
Rear door lock, Child safety rear	
door lock.....	3-6
Rear Driving Aids.....	5-32
Rear personal lights.....	2-98
Rear seats.....	1-7
Rear window and outside mirror	
defroster switch.....	2-60
Rear window wiper and washer switch ...	2-59
RearView Monitor.....	4-3
Recommended fluids/lubricants	
and capacities.....	10-2
Recorders, Event data.....	10-25
Reduction gear fluid.....	8-6
Registering in another country.....	10-5
Remote keyless entry function, For	
Intelligent Key system.....	3-15
Removing tire.....	6-11
Repairing flat tire.....	6-4

S

Replacing tires.....	6-10
Reporting safety defects.....	10-24
Road accident precautions.....	EV-8
Road Assistance.....	6-2
Rollover.....	5-9
Roof rack.....	2-90
Route Assist.....	5-118

Safety	
Child seat belts.....	1-23
Reporting safety defects.....	10-24
Towing safety.....	10-18
Scene guide	
Charging after driving.....	EV-15
Charging the Li-ion battery.....	EV-10
Driving the vehicle.....	EV-13
Parking the vehicle.....	EV-14
Starting your vehicle.....	EV-12
Seat adjustment	
Front manual seat adjustment.....	1-4
Front power seat adjustment.....	1-5
Front seats.....	1-4
Seat belt(s)	
Child safety.....	1-23
Infants.....	1-24
Injured persons.....	1-17
Larger children.....	1-24
Precautions on seat belt usage.....	1-14
Pregnant women.....	1-17
Seat belt cleaning.....	7-7
Seat belt extenders.....	1-22
Seat belt hook.....	1-22
Seat belt maintenance.....	1-22
Seat belt warning light	
and chime.....	1-17, 2-14

Uniform tire quality grading.....	10-23
Wheels and tires.....	8-18
Towing	
Tow truck towing.....	6-20
Towing a trailer.....	10-13
Towing recommended by NISSAN.....	6-22
Towing safety.....	10-18
TPMS, Tire pressure monitoring system.....	5-5
TPMS with Easy Fill Tire Alert.....	5-8
TPMS, Tire pressure warning system.....	6-3
Traction motor	
Traction motor serial number.....	10-6
Traffic Sign Recognition (TSR).....	5-40
Trailer towing.....	10-13
Transceiver	
HomeLink® Universal Transceiver.....	2-99
Transmitter, With Intelligent Key system (See Intelligent Key system).....	3-15
Traveling or registering in another country.....	10-5
Trip computer.....	2-45
Trip odometer.....	2-45
Troubleshooting guide	
Driver Assistance systems.....	5-36
Turn signal switch.....	2-68

U

Underbody cleaning.....	7-3
Uniform tire quality grading.....	10-23
Unlocking with inside handle.....	3-4
USB (Universal Serial Bus) charging connector.....	2-77

V

Vanity mirror.....	3-41
Vanity mirror lights.....	2-99
Vehicle	
Dimensions and weights.....	10-5
Identification number (VIN).....	10-6
Loading information.....	10-9
Recovery (freeing a stuck vehicle).....	6-23
Security system.....	2-55
Vehicle Dynamic Control (VDC) system.....	5-155
Vehicle Dynamic Control (VDC) system.....	5-155
Vehicle information display.....	2-22
Settings.....	2-25
Vehicle information display warnings and indicators.....	2-34
Ventilators.....	4-27
VSP system.....	EV-20

W

Walk away lock function.....	3-11
Warning	
Blind Spot Warning (BSW).....	5-55
Driver Assistance systems troubleshooting guide.....	5-36
Hazard warning flasher switch.....	6-2
Intelligent Forward Collision Warning (I-FCW).....	5-130
Lane Departure Warning (LDW).....	5-44
Lights.....	2-12
Rear Door Alert.....	2-75
Tire Pressure Low - Add Air warning.....	2-35
Tire pressure monitoring system (TPMS).....	5-5, 6-3

Vehicle information display.....	2-22
Warning lights, indicator lights and audible reminders.....	2-11
Warning labels, Air bag warning labels.....	1-68
Warning light	
12-volt battery charge warning light.....	2-12
Air bag warning light.....	1-69, 2-15
Anti-lock Braking System (ABS) warning light.....	2-15
Brake system warning light (yellow).....	2-16
Brake warning light.....	2-13
Electric power steering warning light.....	2-17
Electric shift control system warning light.....	2-13
EV system warning light.....	2-17
Low battery charge warning light.....	2-17
Low tire pressure warning light.....	2-17
Seat belt warning light and chime.....	1-17, 2-14
Washer switch	
Rear window wiper and washer operation.....	2-59
Wiper and washer switch.....	2-56
Washing.....	7-2
Waxing.....	7-3
Weights (See dimensions and weights).....	10-5
Wheel/tire size.....	10-5
Wheels and tires.....	8-18
Care of wheels.....	7-3
Cleaning aluminum alloy wheels.....	7-4
Window washer fluid.....	8-10
Window(s)	
Cleaning.....	7-3
Power windows.....	2-91

Wiper	
Rear window wiper blade.....	8-9
Replacing wiper blades.....	8-8
Wiper and washer switch.....	2-56
Wiper blades.....	8-8
Wiper and washer switch.....	2-56
Wireless charger.....	2-78

MEMO

COLD TIRE PRESSURES

See the Tire and Loading Information label affixed to the driver's side center pillar.

QUICK REFERENCE

- In case of emergency ... "In case of emergency" (P.6-1)
(Flat tire, EV system will not start, overheating, towing)
- How to charge the EV ... "Charging" (P. CH-1)
- How to start the EV system ... "Starting and driving" (P.5-1)
- How to read the meters and gauges ... "Instruments and controls" (P.2-1)
- Maintenance and do-it-yourself ... "Maintenance and schedules" (P.9-1)
- Technical information ... "Technical and consumer information" (P.10-1)

MEMO

MEMO

MEMO

MEMO



To view the digital NissanConnect manual, go to
www.nissanquickguide.com/#/guide/2023/ariya/browse
or snap this QR code with an appropriate QR code reader.



Printing : December 2022
Publication No.: OM23E0 0FE0U2
Printed in the U.S.A.

0FE-D