



2020 NISSAN TOWING GUIDE

The 2020 NISSAN Towing Guide provides information for currently available 2020 NISSAN vehicles. This publication will be amended as new vehicles are introduced.

Table of Contents

Introduction _____	1
Towing Equipment _____	2
What Is Right for You _____	3
Preparing Your Vehicle _____	10
Towing Safety _____	15
Towing Tips _____	18
Towing Glossary _____	22
Protection _____	25
Commitment _____	26

For important safety warnings, please read and follow your vehicle owner's manual.

INTRODUCTION

SAFETY IS PRIORITY ONE

Obviously, your first concern should be safety. Your vehicle was designed to be used primarily to carry passengers and cargo. Always remember that towing a trailer places additional loads on your vehicle's engine, drivetrain, suspension, steering, braking, and other systems. Therefore, be certain that your vehicle can meet the demands of the towing application you have in mind.

Rent or purchase towing equipment that complies with established industry standards and state and federal safety regulations. Reinforced tow hitches designed especially for certain NISSAN vehicles are available from your NISSAN dealer. Hitches for other NISSAN models – if Nissan recommends towing with that vehicle – should be bought from and installed by a professional supplier of towing equipment. Carefully review all information and literature provided with any hitch you purchase for safety and proper use information.

Finally, it is important to follow the towing capacity limit set for your specific vehicle, and to ensure that your vehicle is in top mechanical condition, especially the tires, brakes, suspension, and engine cooling system. See your vehicle owner's manual for details.

WHAT IS THE ESTABLISHED TOWING CAPACITY FOR YOUR VEHICLE

Towing capacities vary from vehicle to vehicle. See the towing information in your vehicle owner's manual to confirm whether your NISSAN vehicle can be used to tow and if so, what its towing capacity rating is. Use this data to help select the proper NISSAN vehicle to meet your anticipated towing needs, and refer to it when renting a trailer or other piece of towing equipment.

EQUIP YOUR NISSAN FOR TOWING

The frequency and type of towing dictate the manner in which you equip your vehicle. If you plan to tow often, for either recreation or work, select the engine size, transmission type, suspension, and towing capacity that are best suited to your requirements. This guide can help you select that equipment.

If, on the other hand, your towing will be infrequent, choose the NISSAN vehicle and equipment that best meets your day-to-day needs. Be careful not to exceed the towing capacity on those few occasions when you do tow.

READ THIS GUIDE BEFORE YOU TOW

This guide was designed to provide an overview of safe towing practices. Here, you will find information on towing equipment, safety, proper loading and driving techniques, towing tips, and much more.

It is also a good idea to discuss your towing requirements with either your NISSAN dealer or a professional supplier of towing equipment before you equip your NISSAN vehicle for towing. Finally, there are state and local laws on towing that you should review to ensure compliance with all regulations.

⚠ CAUTION- Do not use your new vehicle to tow a trailer or haul a heavy load for the first 500 miles (800 km) of use. Your engine, axle or other parts could be damaged. For the first 500 miles that you tow a trailer, do not drive over 50 mph and do not make starts at full throttle. This helps your engine and other parts of your vehicle wear in at heavier loads.

TOWING EQUIPMENT

RENTING

The first thing to keep in mind when renting any type of tow equipment, trailer, or tow dolly, is to rent only from professional companies that specialize in towing and towing equipment. More than likely, specialized companies hire professional staff that can assist you in selecting and installing the proper towing equipment for your NISSAN vehicle.

When renting, make sure you have your vehicle owner's manual on hand so that you can reference the towing capacities for your specific vehicle. Make certain that the tow equipment and components you rent does not exceed your vehicles maximum towing capacity. Make sure that any related towing equipment you rent has the proper weight class rating for your maximum intended towed load weight; do not exceed the maximum Gross Combined Weight Rating.

While you are there, ask questions. How much does the empty trailer weigh? How much weight will the trailer hold? What is the trailer's tongue load? What type of brakes is it equipped with (if any)? All of these factors have an effect on whether your NISSAN vehicle is capable of safely pulling that type of trailer, dolly, or tow equipment.

Make certain that the trailer stoplights, taillights, turn signals, and brakes (if equipped) are connected and operating correctly, and all safety equipment is properly installed. Check the safety chains/cables, tie-downs, etc.

For safer operation, carefully inspect the condition of the trailer and towing equipment. Specifically, check to make sure the tires are not worn excessively and are properly inflated. Make sure there are no broken welds, missing bolts, and that the hitch components are not damaged. Towing safety should be a high priority when choosing and renting towing equipment, including hitches.

⚠ WARNING: NEVER RENT A CLAMP-ON-TYPE HITCH. The hitch should not be attached to or affect the operation of the impact-absorbing bumper. Use **only** a permanent-type hitch properly attached to the vehicle to help avoid personal injury or property damage.

PURCHASING

If you are buying a travel or boat trailer, be sure that your NISSAN vehicle has the towing capacity to pull it. Refer to your vehicle owner's manual for detailed information regarding the towing capacity of your specific vehicle. Your vehicle owner's manual should ALWAYS be referenced before making any towing decisions.

Naturally, you will want to select the towing and safety equipment that adheres to your states and federal safety regulations. Moreover, if you plan to tow often, consider convenience. Quick-disconnect trailer light connectors and ratchet-type tie-downs, for example, make the job go faster and easier and are usually worth the extra small investment. Purchase towing items such as hitches and hitch balls only from your NISSAN dealer or a professional supplier of towing equipment.

If you are intending to use your vehicle to tow a trailer you already own, you must ensure that your loaded trailer remains within your vehicle's towing capacity as specified in the vehicle owner's manual. In addition, you should purchase the right type, style, and class* of hitch and towing equipment to properly adapt the trailer to your vehicle.

WHAT IS RIGHT FOR YOU

TYPES OF EQUIPMENT

Towing requires a variety of equipment, and, depending upon the application, there can be several types or styles of each piece of equipment. Working with your NISSAN dealer or a professional supplier of towing equipment, it should be relatively simple to determine the proper type of equipment for your specific vehicle given the intended application. This section explains the most common pieces of towing equipment available.

HITCHES

Whichever type of hitch you use, it should be firmly bolted to your vehicle, and should be of the appropriate weight class for the trailer, tow dollies, or towing equipment you intend to tow. In addition, keep the following in mind:

⚠ WARNING - Never modify the vehicle's brake or exhaust systems or its body structure/frame when installing the hitch. Modifying the exhaust system structure on a vehicle could result in improper vehicle operation not covered by the vehicle's warranty. It may also lead to carbon monoxide leaking into the passenger compartment. Altering the brake system can adversely affect vehicle handling, braking and performance and could increase the likelihood of an accident or personal injury or death.

* Refer to your owner's manual for the equipment class information specific to your vehicle.

- Installing an aftermarket hitch may affect the rear crash performance of your vehicle. Changing the crash performance of a vehicle could lead to more severe vehicle damage, personal injury or death in a crash. Be sure that the hitch does not interfere in any way with the vehicle's impact-absorbing bumper.

- **Never attach a hitch or towing device to the vehicle bumper. This may affect the operation of the impact-absorbing bumper.** Use **only** a permanent-type hitch properly attached to the vehicle to help avoid personal injury or property damage.

- Regularly check to see that all hitch-mounting bolts are securely fastened to ensure the hitch will not come loose, and remains properly attached to the vehicle to help avoid property damage, personal injury or death.

⚠ CAUTION - For receiver-type hitches using a ball mount, remove the ball mount when not towing, or protect it with a special cover, this will help protect it from damage, and prevent rust from forming on it.

- If you install a hitch yourself, remember that it must be securely attached to the frame or underbody, according to the manufacturer's instructions. **Never attach a hitch or towing device to the vehicle axle housing. This may damage the housing, wheel bearings, wheels, or tires.**

Hitch Types

Bumper Hitch – This is a special reinforced bumper designed to accommodate a standard trailer hitch ball. The light-duty bumper hitch must support the trailer tongue weight all by itself. The maximum towing capacity when using the Genuine Nissan step bumper, as a ball mount hitch is limited to 3,500 lbs. and 350 lbs. tongue load. A Class I trailer hitch is limited to 2,000 lbs. Choose a proper class ball mount based on the trailer weight.

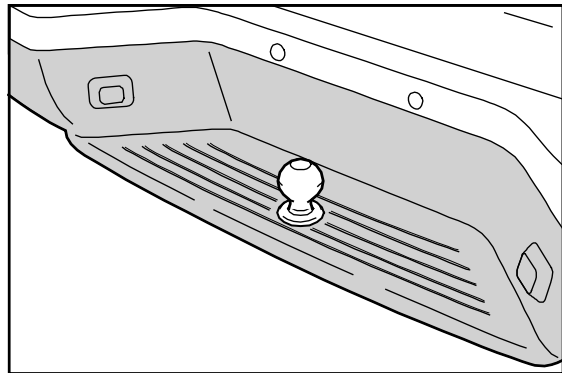

Receiver Hitch – A receiver hitch is bolted directly to the vehicle structure for added strength and durability. NISSAN bolt-on receiver hitches are designed for use with NISSAN vehicles, and include the necessary reinforcements, with ample clearance around bumpers, and frame members, etc. These hitches allow for the removal of the ball mount when not towing.

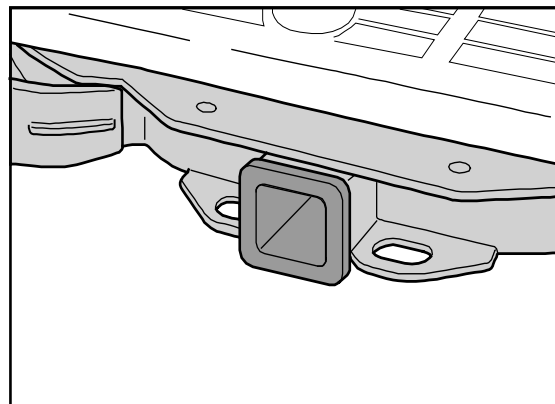

Weight-Distributing Hitch System

- This type of system uses a "load-leveling" or "equalizing" hitch. The weight-distributing feature helps shift trailer tongue weight to all axles of the tow vehicle and all trailer tires.

For Armada, Frontier, Pathfinder, Titan, and Nissan NV vehicles, a weight-distributing hitch ball mount (Class IV) is recommended if you plan to tow trailers with a maximum weight over 5,000 lbs. This ball mount includes a 2-5/16" hitch ball and is available through your NISSAN dealer.

NOTE - A weight-distributing hitch system may affect the operation of trailer surge brakes. If you are considering use of a weight-distributing hitch system with a surge brake-equipped trailer, check with the surge brake, hitch, or trailer manufacturer to determine if and how this can be done. Follow the instructions provided by the equipment manufacturer for installing and using the weight-distributing hitch system.

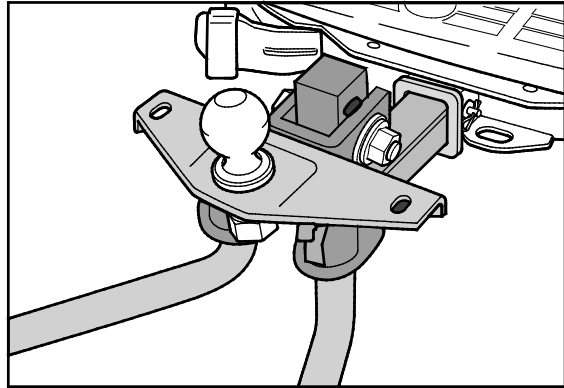

Clamp-On Bumper Hitch - This temporary hitch clamps onto the bumper assembly.

⚠ WARNING-DO NOT USE a clamp-on bumper hitch on any NISSAN vehicle because using it may result in the trailer separating from the towing vehicle. If the trailer separates from the vehicle, it could cause a crash, resulting in property damage and personal injury, or death. Use of this type of hitch can also damage the towing vehicle.

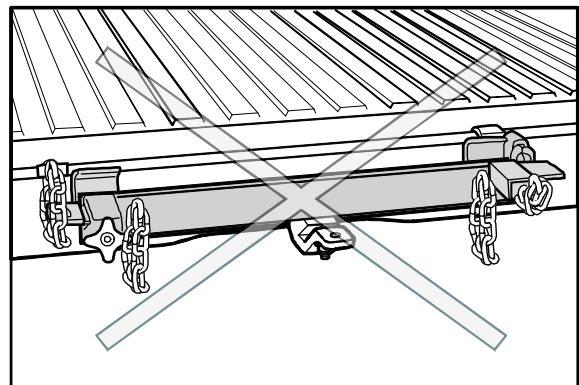

5th Wheel or Gooseneck Hitch –

A 5th wheel or gooseneck hitch mounts in the bed of a pick-up and is designed for heavy-duty applications. A gooseneck hitch is available from NISSAN for the Titan XD. At this time, the Titan XD is the only NISSAN vehicle approved for 5th wheel and gooseneck trailer towing.

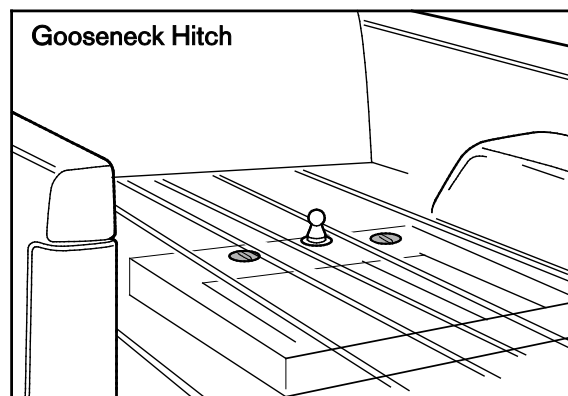
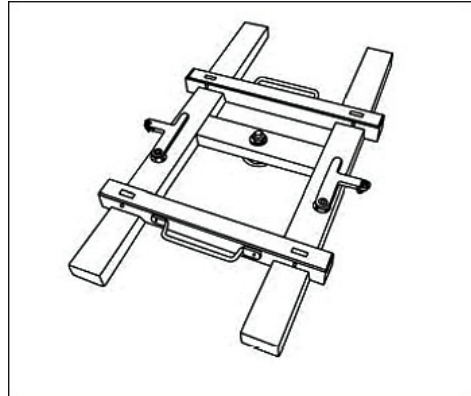

BALL MOUNT

A ball mount (also known as a drawbar) is a bar that holds a hitch ball, which inserts into a receiver-type hitch. Ball mounts come in a number of weight capacities (3,500 lbs., 5,000 lbs., etc.) and sizes (1-1/4", 2", 2 1/2", etc.), and can be weight distributing or non-weight-distributing. Choose a proper class ball mount based on the trailer weight.

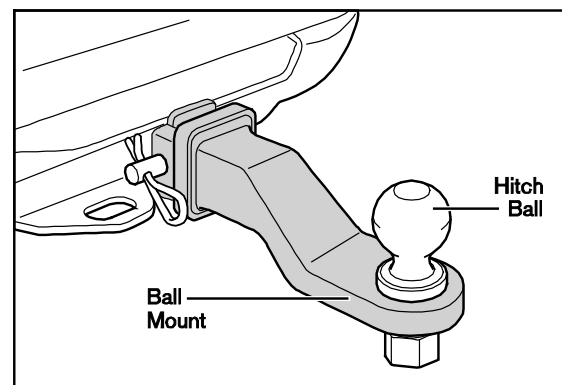

HITCH BALL

A hitch ball is bolted through a ball mount or hitch hole in the tow vehicle's rear bumper. The coupler on the trailer tongue attaches over the hitch ball. Like ball mounts, hitch balls are available in a number of weight capacities and sizes. Most hitch balls have the size stamped on the top of the ball. The required hitch ball size is stamped on most trailer couplers. Always make sure the hitch ball selected has the proper shank diameter and weight rating for the ball mount as well as the coupler on your trailer. Using a 1-7/8" hitch ball in a 2" coupler, for example, could result in the trailer separating from the tow vehicle. The diameter of the hitch ball shank must be matched to the ball mount hole diameter. The shank should be no more than 1/16" smaller than the hole.

To keep the hitch ball in top condition, a simple maintenance routine is recommended. Coating it with light grease will minimize wear of both the coupler and hitch ball. In addition, removing the hitch ball when not towing, or protecting it with a special cover will help prevent rust from forming on it.

TRAILER TONGUE

The tongue is the part of the trailer that extends forward to meet the tow vehicle, and it carries the coupler assembly. Knowledge of the trailer minimum and maximum tongue load (conventional trailers) and king pin load (5th wheel and gooseneck trailers) is critical as it can have a significant effect on the handling and capacity of the tow vehicle. Refer to your vehicle owner's manual to view the maximum conventional trailer tongue load listed for your vehicle. Trailer tongue weight is the amount of downward pressure exerted onto the hitch ball. Keep the tongue load between 10-15% of the total trailer weight. DO NOT exceed the maximum tongue load specification. If the tongue weight is below the recommended amount, you must move some of the load forward or add weight to the front frame of the trailer.

SAFETY CHAINS/CABLES

Always use suitable safety chains/cables between the tow vehicle and the trailer. If the hitch should break or become disengaged while towing, these chains/cables will help provide an emergency connection between the vehicle and the trailer.

When installed properly the chains/cables should be crossed under the trailer tongue, and attached to the hitch or vehicle frame. Crossing the chains/cables under the tongue will help prevent the tongue from hitting the ground should the trailer become disconnected. Be sure to leave enough slack in the chains/cables to turn corners without binding; however, note that excessive slack will allow the chains/cables to drag on the ground.

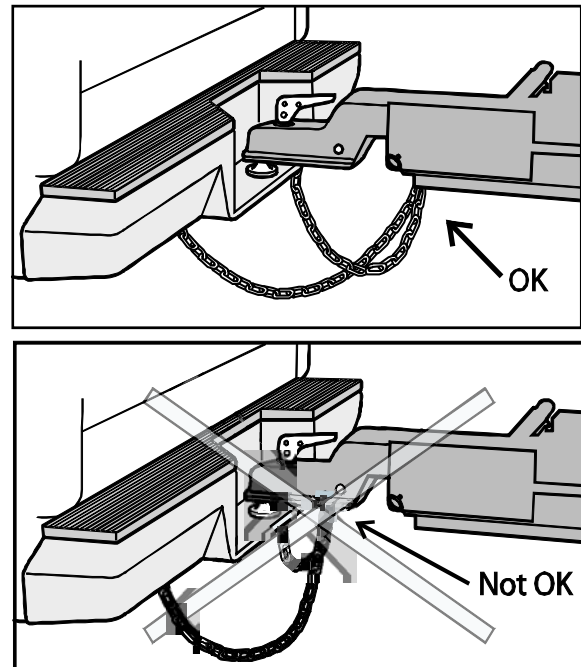

⚠ WARNING- DO NOT use S-hooks for attaching the safety chains as they may become un-hooked while towing. If the S-hook unhooks, the emergency chains/cables will become detached, so if the tow hitch breaks or becomes disengaged, it will allow the trailer to completely break away causing property damage and possibly personal injury or death. The use of S-hooks is illegal in many states.

⚠ CAUTION- To avoid damage to the bumper and chains/cables when making a sharp turn, do not attach the chains/cables too close to the coupler. Consult your trailer manufacturer for the proper location of the chain/cable attachment to the trailer.

REAR VIEW MIRRORS

⚠ WARNING- In many cases, a trailer can block your rear vision when you are using only the standard NISSAN rear view and outside mirrors. Be careful when changing lanes or turning. Using only these mirrors could cause an accident as they were not designed for towing.

Trailer tow mirrors specifically designed for trailer towing can be adjusted for better visibility when your rearward vision is obstructed while towing a trailer. Trailer Tow Mirrors are available as an accessory for certain Nissan vehicles. Before using these mirrors, make certain that they comply with state and local regulations. It is recommended you contact your NISSAN dealer for details.

BREAKAWAY SWITCH

On a trailer with electric brakes, a breakaway switch can automatically activate the trailer brake system if the trailer becomes separated from the tow vehicle. Should the trailer become detached, a breakaway switch may help prevent the trailer from wandering into another lane.

⚠ WARNING - A breakaway switch relies on the power of a trailer battery, so make sure to maintain the battery's charge. Never use the breakaway switch to "park" the trailer on a grade. The battery would eventually discharge and release the brake, allowing the trailer to roll, which may cause property damage, serious injury or death. Be sure to leave enough slack in the tether on the breakaway switch to turn corners without binding. If you do not, the electric trailer brakes will lock-up and not release. See your trailer manufacturer for proper installation of a breakaway switch that is compatible with your trailer braking system.

TRAILER LIGHTS

Trailer lights should comply with all applicable federal, state, and local regulations, and should be in proper working order at all times. A trailer's taillights, stoplights, and turn signal lights must be wired into the tow vehicle's electrical system.*/**

Most trailers operate on a four-wire system in which the stoplights and turn signal lights utilize the same wire. Most all NISSAN vehicles have separate wires for the stoplights and turn signal lights, therefore a device called a "converter" is needed.*** Specifically, a "powered converter" must be used to provide power for all trailer

* Vehicles equipped with LED taillights require that wiring be connected at a specific location. For assistance in hooking up trailer lights, contact your NISSAN dealer or a professional supplier of towing equipment.

** Vehicles not equipped with the factory tow package need a trailer tow harness and relays installed in the passenger kick panel and the trailer plug installed at the hitch.

*** If the vehicle is factory equipped with a trailer wiring connector, then no converter is necessary. If your trailer is equipped with a 4-pin connector, an adapter will be needed to connect the trailer lights to the vehicle. Vehicles equipped with the optional trailer tow package can be equipped with a 7-pin trailer harness connector.

This type of converter creates only minimal additional electrical demand (draw) on the vehicle lighting circuits, which provides protection for the vehicle's sensitive electronics. Always check for correct operation of the taillights, stoplights, and turn signal lights every time you connect a trailer for towing. Never replace vehicle fuses with fuses of a higher amperage rating than the original.

⚠ CAUTION – Improperly installed or poor quality trailer harness wiring may adversely affect your vehicle's electrical system. Use only a NISSAN approved wiring harness, or equivalent, and consult your dealer or a professional supplier of towing equipment to obtain the proper equipment and to have it installed.

BRAKES

As with hitches, several types of braking systems are available. Most states require a separate braking system on trailers with a loaded weight above a specific amount, therefore you should check to ensure you comply with all regulations and laws. Have a professional supplier of towing equipment demonstrate proper brake function testing.

Never connect a trailer brake system directly to the vehicle brake system. Most states require a separate braking system on trailers with a loaded weight of 1,500 lbs. (680 kg) or more.

Surge Brakes – The surge brake actuator is mounted on the trailer tongue with a hydraulic line running to each trailer wheel equipped with disc brakes. Surge brakes are activated by the trailer pushing against the hitch ball when the tow vehicle is braking. Hydraulic surge brakes are common on rental trailers and some boat trailers. In this type of system, there is no hydraulic or electric connection for brake operation between the tow vehicle and the trailer.

Electric Trailer Brakes – Electric braking systems are activated by an electronic signal sent from a trailer brake controller (special brake-sensing module). If electric trailer brakes are used and the vehicle is not equipped with an integrated trailer brake controller, NISSAN recommends the installation of a compatible aftermarket trailer brake controller. For adjustment specifications, refer to the manufacturer's instructions of the brake controller being installed. For your convenience, Armada, Frontier, Pathfinder, Titan, and NV vehicles are pre-wired to accommodate most popular electric trailer brake controllers. A wiring harness* is either included with your vehicle or available from your NISSAN dealer. This harness provides electric trailer brake controller input and output connections to the vehicle wiring. See a professional supplier of towing equipment for electric trailer brake controller availability.

*Contact a NISSAN dealer or a professional supplier of towing equipment for information on trailers equipped with electric brakes and for Genuine NISSAN jumper harness availability for your specific vehicle.

⚠ CAUTION - The NISSAN trailer brake controller has been verified to be compatible with trailers having electric actuated drum brakes (one to four axles) and electric-over-hydraulic brakes. It will not activate hydraulic surge-style trailer drum brakes.

SWAY CONTROL DEVICE

Sudden maneuvers, wind gusts, and buffeting caused by other vehicles can affect trailer handling. Sway control devices may be used to help control these effects. If you choose to use one, contact a reputable trailer hitch supplier to make sure the sway control device will work with the vehicle, hitch, trailer and the trailer's brake system. Trailer sway control is a function of vehicles equipped with the Vehicle Dynamic Control (VDC) system and is active when the VDC function is enabled

GENUINE NISSAN PARTS AND ACCESSORIES

Whether you will be towing occasionally or on a regular basis, NISSAN offers a full range of Genuine NISSAN Parts and Accessories to help you tow with confidence. Every Genuine NISSAN Parts and Accessory is thoroughly tested and inspected for fit and workmanship. Therefore, you can be certain that every item is designed to be compatible with the standard features of your vehicle and designed to assist you with your towing needs. It is recommended you contact your NISSAN dealer for more information on accessories or towing-related parts for your NISSAN vehicle.

PREPARING YOUR VEHICLE

BREAK-IN AND MAINTENANCE SCHEDULE

⚠ CAUTION - NISSAN recommends that you allow a sufficient "break-in" (500 miles) of both the engine and drivetrain before towing with your new NISSAN vehicle. **Do not** tow a trailer or haul a heavy load for the first 500 miles. For the first 500 miles that you tow a trailer, **do not** drive over 50 mph and **do not** make starts at full throttle. This helps the engine and other parts of your vehicle wear in at heavier loads.

Keep in mind, too, that towing places higher demands and added loads on vehicle components, so more frequent maintenance is called for. Your NISSAN Service & Maintenance Guide provides the accelerated maintenance schedule for towing purposes. Engine oil, filter, transmission fluid, and possibly other fluids should be changed more frequently when towing.

MEASURING VEHICLE WEIGHT

The key to safer, efficient towing has to do with weight. Your vehicle – SUV, crossover, or truck – is capable of carrying and towing only a certain amount of weight. You must compare your vehicle’s tow weight ratings with the combined weight of the vehicle, trailer, and their contents. This will help ensure that the total weight does not exceed any of your vehicle’s tow weight ratings.

There are four weights to consider when towing:

- ◆ Gross Vehicle Weight
- ◆ Gross Axle Weight (Front or Rear)
- ◆ Gross Combined Weight
- ◆ Trailer Tongue/King Pin Load

These ratings are based upon normal highway driving and may be reduced if operating in reduced-traction situations, (for example, slippery boat ramps).

⚠ WARNING – Attempting to tow loads greater than the GVWR, GAWR, GCWR, overloading and/or improperly loading the trailer tongue/king pin load specified could adversely affect vehicle handling, braking, and performance. This may result in unsafe vehicle handling and longer braking distance, which could result in a serious accident and personal injury. Failures to your vehicle caused by overloading are not covered by your vehicle’s warranty.

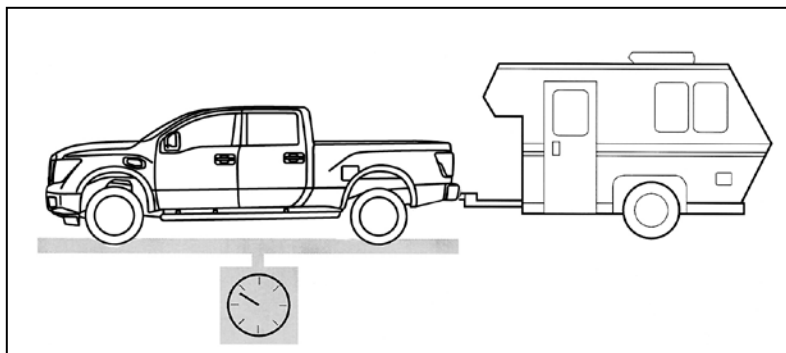

GROSS VEHICLE WEIGHT (GVW)

The Gross Vehicle Weight (GVW) is the actual weight as weighed on a scale - including passengers, cargo, fuel, hitch, trailer tongue/king pin load, and any optional equipment.

The best way to determine the GVW is by having the vehicle – loaded and ready to tow – weighed at a public scale. That figure must include the combined weight of all passengers and cargo that are normally in the vehicle when towing a trailer.

The GVW you come up with must not exceed the Gross Vehicle Weight Rating (GVWR) for your vehicle.

On all NISSAN vehicles, the **GVWR** is shown on the Federal Motor Vehicle Safety Standard (F.M.V.S.S.) certification label located in the driver's-side door area.

Weigh your vehicle on the scale with all of the passengers and cargo that are normally in the vehicle when pulling a trailer. Subtract the actual vehicle weight from the GVWR. The remaining amount is the available maximum tongue/king pin load.

To avoid overloading the vehicle, be sure to include the trailer tongue/king pin load as a part of the cargo when determining how much weight can be safely carried inside the vehicle.

F.M.V.S.S. Certification Label		
MFD BY NISSAN MOTOR CO., LTD.		
DATE		
GVWR		
GAWR FR.		
WITH	RIMS AT	TIRES
		PSI
COLD SINGLE		
GAWR RR.		
WITH	RIMS AT	TIRES
		PSI
COLD SINGLE		
THIS VEHICLE CONFORMS TO ALL APPLICABLE FEDERAL MOTOR VEHICLE SAFETY STANDARDS IN EFFECT ON THE DATE OF MANUFACTURE SHOWN ABOVE. SEE OWNERS MANUAL FOR ADDITIONAL INFORMATION.		
TYPE:	TRUCK	
MODEL:		3B000
COLOR:	TRIM	TRANS
AXLE		ENGINE

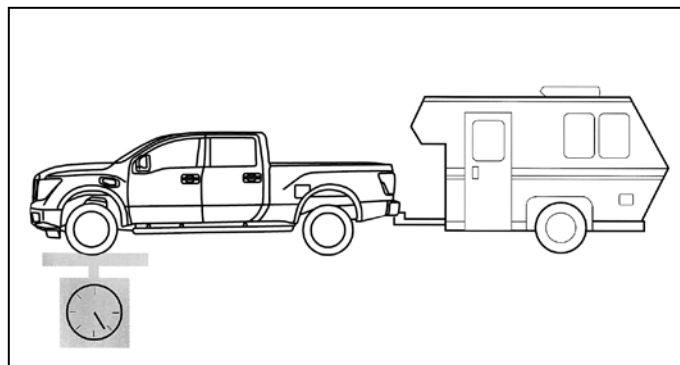

GROSS AXLE WEIGHT (GAW)

The Gross Axle Weight (GAW) is the maximum weight placed on a single axle (front and rear) that it is designed to safely carry.

To determine the GAW, load the vehicle as you would for towing and attach the loaded trailer. At a public scale, with the loaded trailer attached, place only the tow vehicle's front wheels on the scale to determine the actual **front axle** GAW. To obtain the **rear axle** GAW, place all four tow vehicle's wheels on the scale. From that figure, subtract the **front** GAW and you will have the **rear** GAW amount. The cargo in the trailer and the vehicle may have to be distributed, or some removed to meet the specified rating.

The GAW you come up with must not exceed the Gross Axle Weight Rating (GAWR) for your vehicle. On NISSAN vehicles, the GAWR for both axles is listed on the F.M.V.S.S. certification label.

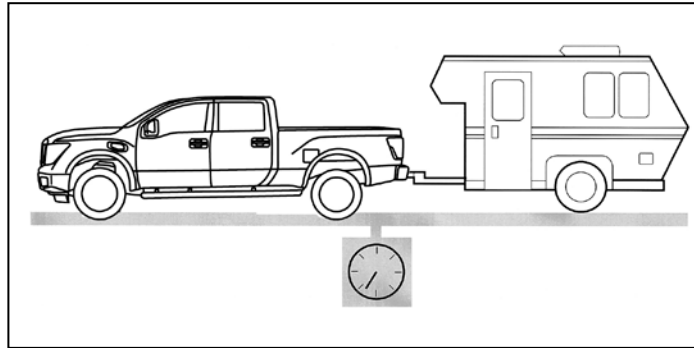

GROSS COMBINED WEIGHT (GCW)

The Gross Combined Weight (GCW) is the total weight of the tow vehicle with all passengers, cargo, and fuel, **plus** the total weight of the trailer and all its cargo. To determine the GCW, simply weigh your vehicle when fully loaded and ready to tow, and add in the weight of the loaded trailer.

The GCW you come up with must not exceed the Gross Combined Weight Rating (GCWR) for your vehicle. Refer to your vehicle owner’s manual to view the maximum GCWR specification listed for your vehicle.

TRAILER TONGUE/KING PIN LOAD

The amount of trailer’s weight pressing down on the tow vehicle hitch ball is called *trailer tongue load* (conventional trailer) or *king pin load* (5th wheel and gooseneck trailers).

To measure trailer tongue/king pin load, place the tongue of the trailer on a scale when the trailer is not attached to the vehicle.

A separate vehicle jack — not the trailer jack — should be used, as the location of the trailer jack is rearward of the trailer tongue and will not give you an accurate measurement of the true tongue/king pin load. Make sure the vehicle jack

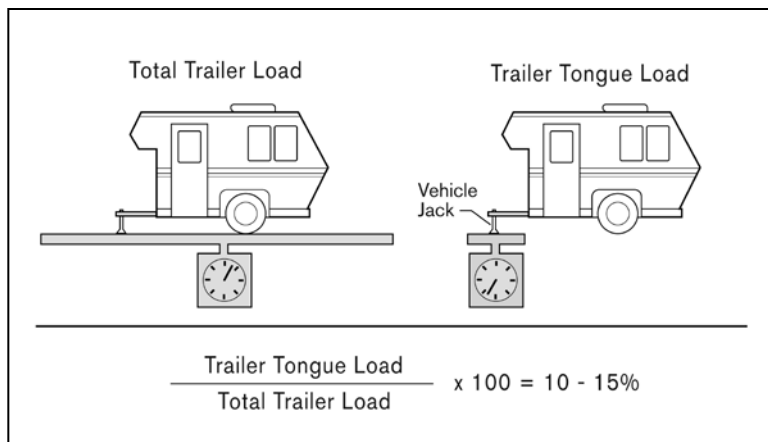

is placed directly under the trailer tongue coupler, and the tongue is set at the height/level of the tow vehicle hitch.

For proper handling, you must keep conventional trailer tongue load between 10-15% of the actual trailer weight, within the limits of the maximum trailer tongue load allowable.

For example, to determine the proper trailer tongue load for a 1,500-lb. trailer, multiply the weight of 1,500 lbs. by 10% to arrive at a figure of 150 lbs. 5th wheel and gooseneck trailer king pin load must be kept between 15-25% of the actual trailer weight, within the limits of the king pin load allowable.

Some trailer types may require different trailer tongue loads for safe towing. Always follow the trailer manufacturer's recommendations for proper trailer set-up and trailer tongue load. Keep the trailer tongue load within the maximum trailer tongue load allowable. Additionally, make sure the vehicle has the payload capacity available for the trailer tongue load.

Refer to your vehicle owner's manual to view the maximum conventional trailer tongue load listed for your vehicle.

⚠ WARNING – DO NOT exceed any of the individual vehicle weight ratings (GVWR, GAWR, GCWR, etc.), regardless of trailer or hitch type. Overloading or improper loading of a trailer can cause unsafe vehicle handling, braking and performance and may lead to a serious accident and personal injury or death.

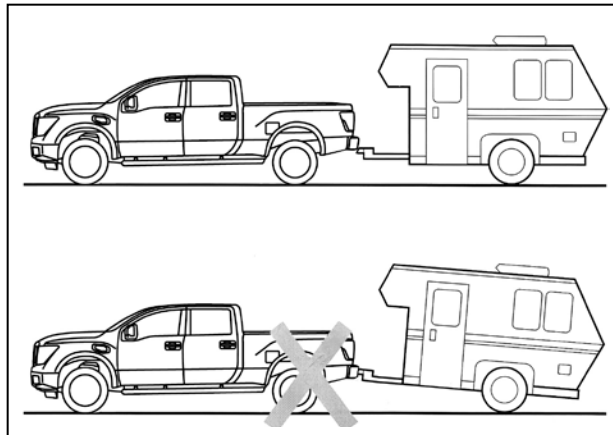

HITCH & TRAILER HEIGHT

It is important that your trailer floor and tongue ride as level as possible. This will help prevent over-angling, bottoming-out, and improper tongue load and load transfer. Therefore, the hitch or trailer tongue must be adjusted during the initial vehicle/trailer fit-up to ensure a level ride. On some tandem axle trailers, an incorrect hitch height can result in uneven trailer axle loading. Ball mounts are available in different configurations to adjust the hitch ball height.

TIRE PRESSURE

When towing a trailer, ensure that the tow vehicle's tire pressures are inflated to the recommended cold tire specification. You will find these figures in the vehicle owner's manual and on the tire pressure chart located in the vehicle. Trailer tire condition, size, load rating, and tire pressure must be in accordance with the trailer and tire manufacturer's specifications.

TOWING SAFETY

Towing can significantly alter the handling and performance characteristics of your vehicle. Moreover, it puts increased strain on the engine and drivetrain. Therefore, it is always a good idea to approach towing from the standpoint of safety – whether you are purchasing equipment or actually pulling the trailer. Buy or lease only quality equipment. You should follow a more frequent maintenance schedule and check fluid levels, proper tire pressures, tire condition, etc., more often when on the road to protect your vehicle.

⚠ WARNING - Always make sure your vehicle's towing capacity is adequate for the trailer you intend to tow. Be certain that you have all of the proper equipment needed for safe towing, such as safety chains/cables, electric trailer brakes, electric trailer brake controller, breakaway switch, and extended rear view mirrors to help ensure against the possibility of a serious accident and personal injury or death.

LOADING YOUR TRAILER

⚠ WARNING - Taking the time to load and balance your trailer properly, will improve overall handling and minimize the strain on your tow vehicle. Incorrectly, loaded trailers tend to sway or swing from side to side, upsetting vehicle handling which could result in a serious accident and personal injury or death. Careful loading and balancing can help eliminate these problems.

As mentioned earlier, conventional trailer tongue load must fall between 10-15% of the total trailer weight, or within the limits of the maximum trailer tongue load specified by the trailer manufacturer. King pin load – if using a 5th wheel or gooseneck trailer – must be between 15-25% of the total trailer weight.

⚠ WARNING - Excessive tongue/king pin load can actually push down the tow vehicle in back, lifting the front wheels to a point where traction, steering response, and braking may be severely reduced. Too little tongue/king pin load can cause instability, which may lead to swaying, "tail wagging" or jackknifing which could result in a serious accident or personal injury or death .

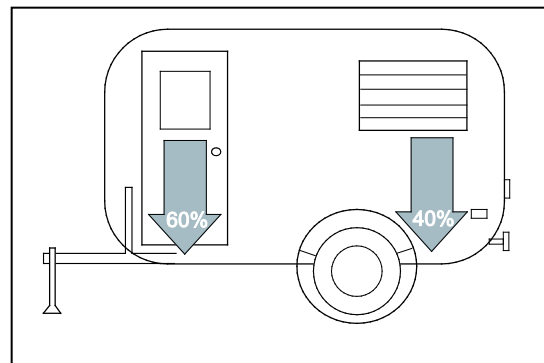

With this in mind, proper loading is extremely important. When loading a trailer, 60% of the total cargo weight should be positioned in the front portion of the trailer and 40% in the back. Then, adjust the load until the proper tongue/king pin load ratio is achieved.

⚠ WARNING -The trailer load should be balanced equally from side-to-side. Unequal side-to-side loading can negatively affect handling and braking. Once in place, all cargo should be firmly secured to prevent shifting. If the load should shift abruptly during braking or cornering, it could quickly affect the handling of your vehicle and cause a very unsafe situation, loss of control or serious accident or death.

- **Do not** carry flammable materials, such as gasoline, in your trailer. In the event of an explosion or fire could occur, causing personal injury or death.

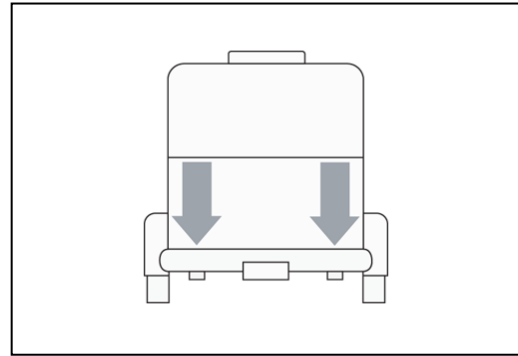

PROVIDING FOR VEHICLE/TRAILER STABILITY

⚠ WARNING - Improper loading, excessive or insufficient trailer tongue/king pin load, overloading, excessive trailer weight, poorly designed trailer suspensions, crosswinds, and poor maintenance are all things that can affect the stability of your vehicle and trailer combination. Vehicle instability may result in loss of vehicle control and cause an accident, personal injury or death.

If swaying does occur, check the cargo load for proper balance and distribution to ensure proper trailer tongue/king pin load. In addition, check the condition of the suspension and shocks, as well as the tires, tire pressures, and wheel bearings on both the tow vehicle and the trailer. If the swaying continues and your trailer is suitably balanced and within the towing capacity limits of your vehicle, discontinue towing and consult your NISSAN dealer or trailer manufacturer to determine the cause.

VEHICLE SPEED

Please note that some states have specific regulations and speed limits for vehicles that are towing trailers. Remember to reduce your speed in unsafe or less-than-ideal road conditions or weather. When towing a trailer, braking distances increase while handling agility decreases. Always leave yourself an extra margin of distance to respond to emergencies.

PASSENGERS

⚠ WARNING - Never allow passengers to ride inside a trailer while it is being towed because there are no passenger restraints in a trailer. Not only is this unlawful in most areas, passengers could be seriously injured or killed during sudden trailer movement or in an accident. In addition, trailers may allow fumes from the tow vehicle to leak inside. This could result in carbon monoxide poisoning from the engine exhaust.

VEHICLE MODIFICATIONS

⚠ WARNING - DO NOT modify your vehicle beyond those required for proper hitch installation, wiring hook-up, or adding extended mirrors on any NISSAN vehicle being used for towing purposes. Changes to the drivetrain, suspension, exhaust systems, frame structure/unibody, or other vehicle components are not necessary for towing within the limits described in this guide. The towing limits of your vehicle cannot be increased beyond the published limits described in this guide or in your owner's manual. Any changes may diminish the reliability and longevity of your vehicle, void warranty coverage or possibly result in loss of vehicle control and cause an accident, personal injury or death.

TOOL KIT

When towing, bring tools including, lugwrench for the trailer wheels, flares, a flashlight, emergency reflectors, jumper cables, extra fuses, extra radiator coolant, oil, and easily replaced spare parts such as taillight bulbs. You should also carry spare tires for your tow vehicle and trailer, as well as a jack suitable for use on the trailer. A trailer jack is an important part of safe towing. Choose a jack that can raise and lower the trailer so that you can connect the coupler to and disconnect it from the ball of your hitch. Choose one with a weight capacity that matches or surpasses your trailer tongue weight.

⚠ WARNING - Be aware that your automotive jack is designed for lifting only your vehicle during a tire change. Using an automobile jack to lift a trailer-bearing load may be unstable possibly causing it to fall off the jack stand which may result in property damage or serious injury or death.

BEFORE STARTING OUT

Before starting out on a trip, make one last inspection of the tow vehicle and the trailer. Are the tire pressures correct? Are the safety chains/cables securely in place? Has the cargo been tied down securely? Do all the lights work? Is the coupler properly attached over the hitch ball and secured using a locking pin? Is the breakaway switch hooked up and functioning properly? Are vehicle and electric trailer brakes working properly?

Make a checklist of key items to inspect. Before towing, always check the tow vehicle's engine oil, transmission oil, and coolant before starting out. Finding a potential problem while in your driveway is better than discovering it miles from home.

TOWING TIPS/ CAUTIONS & WARNINGS

If you have never towed a trailer before, be aware that it does take getting used to. To begin with, towing noticeably affects your vehicle's performance:

- ♦ It will not accelerate as quickly – an important point to keep in mind when merging onto a highway.
- ♦ It will not stop as quickly. Leave more room than usual between you and the traffic ahead, and brake sooner when coming to a stop.
- ♦ Abrupt maneuvering can unbalance the load and reduce the handling and stability of your tow vehicle. Always be aware and plan ahead to make lane changes and turns smoothly.

If possible, before you actually hit the open road, practice towing in a large uncrowded area such as a safe, open place with minimal traffic. Become especially familiar with backing up a trailer – the maneuver many people find most difficult.

BRAKE SOONER

The combination of your tow vehicle and trailer obviously requires a greater distance to stop. A good rule of thumb to remember is that for each 10 mph of speed, allow yourself one tow vehicle and trailer length of distance between the front of your vehicle and the vehicle ahead.

When braking, use firm but gradual pressure on the pedal rather than panic braking.

⚠ WARNING - Applying the brakes abruptly or with too much force can cause a sudden shift in weight which can cause the trailer to skid or jackknife at its point of attachment with the vehicle. This, in turn, can throw the tow vehicle out of control resulting in an accident, property damage or serious injury. If equipped with an electric trailer brake controller, follow the recommended operational instructions.

PASS CAREFULLY

As mentioned in the introduction to this section, because of the added weight of the trailer, acceleration capability is reduced and you will require a longer distance to pass another vehicle. Be certain you have sufficient time and space to pass safely.

⚠ WARNING - Never attempt to pass on hills or when going around curves. This could possibly result in loss of vehicle control and cause an accident, personal injury or death.

CORNER MORE SLOWLY

Know your vehicle and trailer capabilities.

⚠ WARNING - Entering a sharp corner too quickly or abruptly can “crack the whip,” whereby the trailer can actually pull the tow vehicle off the road. Doing so could cause a loss of vehicle control and result in accident, property damage or personal injury.

Therefore, when approaching a relatively sharp corner, begin braking sooner than you would when not towing. Do your braking in a straight line prior to the corner, and turn smoothly into it. In addition, remember to make a wider turn than normal to ensure that the trailer safely clears the inside of the turn.

⚠ WARNING - When towing a 5th wheel or gooseneck trailer, do not make sharp turns while driving or backing as the trailer may contact the vehicle and cause damage to both the trailer and vehicle, or result in an accident leading to property damage or personal injury.

A special extended 5th wheel pin box or sliding hitch may be required to provide additional trailer-to-truck clearance for tight maneuvering.

BACK UP WITH CAUTION

Backing up with a trailer is a difficult maneuver. The best way to steer is by placing one hand at the bottom of the steering wheel to direct the trailer. The trailer will go in the same direction your hand moves. If you want to turn the trailer to the left, you will turn the steering wheel to the left. To turn the trailer to the right, move the wheel to the right. All movements of the wheel should be done in small increments. Of course, backing up should be done only at very slow speeds. For large trailers that obstruct your rearward vision, have someone outside the vehicle act as a “spotter” to guide you along.

PARK SMART

A tow vehicle and trailer can be an unwieldy combination in a small area, so always try to park where you will have a relatively easy time maneuvering. Once parked, always block the wheels on both the tow vehicle and the trailer. Parking on a slope is not recommended. If, however, you must park on a slope and your vehicle is equipped with an automatic transmission, there are some precautions you should take:

- ◆ Have someone block the wheels once the tow vehicle and trailer are in position and are being held by the vehicle’s brake.
- ◆ Next, apply the parking brake and only then move the gear lever into PARK.

⚠ CAUTION - If you move the lever into PARK before blocking the wheels and applying the parking brake, it may be difficult later to shift out of PARK. Transmission damage could also occur.

HIGH-ALTITUDE PERFORMANCE

An engine will lose about 4% of its performance for every 1,000 feet above sea level that you travel. If you will be towing in high altitudes, it is a good idea to allow more time than usual due to the engine's reduced performance.

TOW MODE (IF EQUIPPED)

Tow Mode is recommended when towing a heavy trailer or hauling a heavy load, in stop-and-go traffic, rolling terrain, or a busy parking lot. Driving the vehicle in Tow Mode may affect fuel economy and transmission/engine driving characteristics. See your vehicle owner's manual for additional information about Tow Mode.

HILLS - UPGRADES

As the incline increases, if your vehicle is equipped with an automatic transmission — it is designed to select automatically the correct gear for the best towing comfort and performance. To maintain speed or avoid up and down shifts, manually shift to a lower gear as needed.

The added weight of a trailer places an increased load on the engine and cooling system, so monitor your coolant temperature gauge and automatic transmission fluid temperature gauge (if equipped) carefully. At the first sign of overheating, pull to the side of the road. See IF YOUR ENGINE OVERHEATS later in this section for more information.

HILLS - DOWNGRADES

⚠ WARNING - While going downhill, the weight of the trailer pushing on the tow vehicle may decrease overall stability, and may deteriorate overall handling characteristics, which could result in an accident, property damage, serious injury or death. Therefore, to maintain adequate control, reduce your speed and shift to a lower gear. If your vehicle is equipped with Tow Mode, see your vehicle owner's manual for information about the use of this function.

Avoid long or repeated use of the brakes when descending a hill, as this reduces their effectiveness, and could cause overheating. Shifting to a lower gear instead provides "engine braking" and reduces the need to brake as frequently.

AUTOMATIC CRUISE CONTROL

⚠ WARNING - In order to maintain a safe distance to the vehicle ahead to avoid the possibility of accidents, property damage, serious injury or death, **never** use the Intelligent Cruise control (ICC) system while towing a trailer or other vehicle. If the ICC sensor cannot detect the reflector on the vehicle ahead, the system may not function properly.

IF YOUR ENGINE OVERHEATS

"A moderate increase in engine operating temperature is normal when towing a trailer." If, however, the coolant temperature gauge reading is abnormally high, if you are experiencing a significant loss of power, or if you hear unusual engine noises,* the engine may be overheating and you should immediately take the following steps:

1. Carefully pull your vehicle safely over to the side of the road, out of traffic. Apply the parking brake and move the gearshift lever to NEUTRAL (manual) or PARK (automatic). **DO NOT STOP THE ENGINE.**
2. Turn off the air conditioning and, after opening all the windows, turn the heater on to maximum hot and the fan to its highest speed, and exit the vehicle. The heater core in your vehicle is just like a miniature engine radiator and will provide an extra cooling surface to help reduce engine temperature.
3. If the temperature does not drop or continues to increase, stop the engine immediately.
4. Being cautious of traffic, step out of the vehicle and, from a safe distance, look for steam underneath the engine. If you see steam or leaking coolant, stand clear to avoid being burned and shut off your engine immediately and allow it to cool. If there is no steam, open the hood.

⚠ WARNING - To avoid the danger of being scalded, **do not** open the hood if steam is coming out. Never remove the radiator cap when the radiator is hot. If the cap is removed under these conditions, pressurized hot water/coolant may spurt out, possibly causing serious injury.

5. As soon as the engine has cooled (well below normal operating temperature), visually inspect the drive belts for damage or looseness. A loose belt reduces water pump efficiency.

⚠ WARNING - Be careful to keep your hands, hair, jewelry, and clothing clear of the running drive belt and other moving parts when inspecting the engine and radiator to avoid being burned and to avoid personal injury, or death. Keep in mind, too, that if your vehicle is equipped with an electric fan motor, it may start without warning any time the coolant temperature is high. Also, check to see if the cooling fan is running, and inspect the water pump, radiator, and radiator hoses for leaks.

*See your vehicle owner's manual for additional indications that your vehicle may be overheating.

If you find leaking coolant, a loose or missing drive belt, or an inoperable fan, turn off the engine immediately.

6. If no leaks are apparent and all other components appear to be operating properly, when the engine has cooled to its normal operating temperature; check the coolant level in the reservoir tank with the engine running. Add coolant to the reservoir tank in accordance to owner's manual, if needed. At this point, if repairs are needed, go to the nearest NISSAN dealer. See the IN CASE OF EMERGENCY section of your vehicle owner's manual for additional information on overheating.

NOTES – All NISSAN vehicles have an engine protection mode, which helps reduce the chance of engine damage if the engine coolant reaches a specified temperature. See your vehicle owner's manual for details.

- 1 Maximum Trailer Weight values are calculated assuming a base vehicle with driver and any options to achieve the rating. Additional passengers, cargo and/or additional optional equipment will add weight to the vehicle and reduce your vehicle's maximum towing capacity and trailer tongue load.
- 2 Use of a weight-distributing hitch system is required when towing over 5,000 lbs.
- 3 The Maximum Trailer Weight and Gross Combined Weight ratings for 5th wheel and gooseneck trailer towing are the same as specified for conventional trailer towing.
- 4 Most states require a separate braking system on trailers with a loaded weight above a specific amount. Check local regulations where you plan to tow. A 4 or 7-pin type connector trailer wire harnesses may be required for use with trailer brakes (available separately).

Other Recommendations and Information – Towing performance and speed are affected by vehicle payload, tow weight, road grades, and weather conditions, including high temperatures. See your vehicle owner's manual for details.

TOWING GLOSSARY

5TH WHEEL HITCH	<i>Located just forward of the rear axle centerline, this hitch uses a king pin to serve as the pivot point for the trailer.</i>
------------------------	--

BALL MOUNT	<i>A bar that holds the hitch ball and is inserted into the hitch receiver. Also commonly called a drawbar.</i>
BREAKAWAY SWITCH	<i>A safety device using a trailer battery that automatically applies the trailer's brakes if the trailer accidentally becomes separated from the tow vehicle. A breakaway switch may be used with both electric or surge trailer brake systems.</i>
BUMPER HITCH	<i>A reinforced bumper designed to accommodate a hitch ball.</i>
ELECTRIC TRAILER BRAKES	<i>When the brakes on a tow vehicle are applied, an electric current is sent to an actuator, which applies the trailer's brakes.</i>
ELECTRIC TRAILER BRAKE CONTROLLER	<i>A device that controls the electric trailer brakes.</i>
GOOSENECK HITCH	<i>Located just forward of the rear axle centerline, this hitch uses a ball to serve as the pivot point for the trailer.</i>
GROSS AXLE WEIGHT RATING (GAWR)	<i>The maximum amount of weight each vehicle axle (front or rear) is designed to safely carry.</i>
GROSS COMBINED WEIGHT RATING (GCWR)	<i>The maximum allowable combined weight of the vehicle and trailer, including passengers and all cargo.</i>
GROSS VEHICLE WEIGHT RATING (GVWR)	<i>The maximum allowable weight of the vehicle, including passengers, cargo, fuel, hitch, trailer tongue load, and any optional</i>
KING PIN LOAD	<i>The amount of trailer (5th wheel or gooseneck) weight pressing down on the tow vehicle hitch.</i>

HITCH BALL	<i>A ball that connects the trailer to the tow vehicle hitch that provides the means by which the trailer pivots during cornering. Available in a number of sizes and weight capacities, it must correspond to the trailer coupler size, and have a sufficient capacity rating for the trailer being pulled.</i>
RECEIVER HITCH	<i>A frame- or structure-mounted hitch with a receiver that allows removal of the ball mount.</i>
SAFETY CHAINS/CABLES	<i>Provides an emergency connection between the tow vehicle and the trailer, should the trailer become disengaged for any reason.</i>
SURGE BRAKES	<i>Hydraulic-type braking system activated by inertia. As the tow vehicle begins to brake, the trailer pushes against the hitch ball, consequently activating the trailer brakes.</i>
TRAILER LIGHT CHECK	<i>The system allows you to visually check the trailer brake lights as you cycle through them, controlled by the Intelligent Key.</i>
TRAILER TONGUE/COUPLER	<i>The part of the trailer that extends forward to meet the tow vehicle, and carries the coupler assembly.</i>
TRAILER TONGUE LOAD	<i>The amount of trailer (conventional) weight pressing down on the tow vehicle hitch.</i>
WEIGHT-DISTRIBUTING HITCH SYSTEM	<i>Type of hitch system that helps shift the trailer tongue weight to all trailer tires and the tow vehicle front tires. Strongly recommended when towing trailers with a Maximum Trailer Weight greater than 5,000 lbs.</i>
WIRING HARNESS	<i>Provides an electrical connection linking the tow vehicle's electrical system to the trailer's system.</i>

PROTECTION

At NISSAN, we back everything we build. Therefore, we are proud that every NISSAN is protected by some of the best New Vehicle Limited Warranties, including a 36 month/36,000-mile basic coverage. 2020 models also feature 60 month/60,000-mile Limited Powertrain Warranty, (with the exception of 2020 Nissan U.S. TITAN and NISSAN NV which have a 60 month/100,000-mile Basic New Vehicle Limited*, and a 60 month/100,000-mile Powertrain Warranty coverage*). NISSAN warranties are completely transferable if you should sell your NISSAN.

If you want additional peace of mind, we proudly offer the NISSAN Security+Plus[®] Vehicle Protection Plan. This plan offers quality mechanical protection long after your New Vehicle Limited Warranty expires. The Security+Plus Vehicle Protection Plan is backed by NISSAN and designed exclusively for NISSAN owners. From a variety of plans available, you can choose the one that best fits your driving needs (up to 7 years/100,000 miles). For the maximum coverage, you will want to opt for Security+Plus Gold[®] Preferred.

Whichever plan you choose, coverage is available throughout the United States. Repair work will be done at authorized NISSAN dealers by NISSAN-trained technicians utilizing Genuine NISSAN Parts. For more information about Security+Plus Vehicle Protection Plans, contact your participating NISSAN dealer.

The quality of Genuine NISSAN Parts and Accessories is backed by the integrity of a Genuine NISSAN Replacement Parts and Accessories Limited Warranty. If purchased within the basic coverage period of 36 month/36,000 miles, Genuine NISSAN Parts and Accessories are covered by the remaining period of the warranty. If the remaining period is less than 1 year/12,000 miles (or if the vehicle warranty has expired), then Genuine NISSAN Accessories are covered by their own 1-year/12,000-mile Limited Warranty. See your NISSAN Warranty Information Booklet or ask your NISSAN dealer for specific details.

* For complete warranty details, read the 2020 NISSAN Warranty Information Booklet or see your nearest NISSAN dealer.

CONCERN FOR YOUR SAFETY

NISSAN urges you to always use your seat belt whenever you drive. Also, please make sure all passengers are buckled up. Keep in mind that air bags are a supplemental restraint system and must always be used in conjunction with a seat belt.

In addition, a rear-facing child restraint must never be used in the front passenger seat if the vehicle is equipped with a front passenger air bag. Children 12 and under should ride in the rear seat properly secured in child restraints, booster seats, or seat belts, according to their size. See your vehicle owner's manual for more details.

COMMITMENT

At NISSAN, our commitment to your satisfaction extends well beyond building a full line of quality products. It begins with people dedicated to designing vehicles to satisfy your needs. Then, building them to standards that are beyond your expectations. Our nationwide network of nearly 1,100 dealers will help you select the NISSAN that is right for you.

For further assistance, search our Web site at www.NISSANUSA.com. For NISSAN dealer locations or for more information on this and other NISSAN products, call 1-800-239-8810. Or, call 1-800-NISSAN-1 for answers to product-related issues and solutions to your transportation needs.

All illustrations and specifications in this document are based on the latest product information available at the time of publication. Please see your Owner's Manual for important safety information and system operation limitations. NISSAN North America, Inc. reserves the right to make changes at any time, without prior notice, in materials, equipment, specifications, and models, and to discontinue models or equipment. Features and equipment in your vehicle may vary depending on model, trim level, options selected, order, date of production, region or availability. Therefore, you may find information about features or equipment that are not included or installed on your vehicle. For information on availability, options or accessories, contact your NISSAN dealer.

NISSAN, the NISSAN Brand Symbol, "Innovation that excites" slogan, and NISSAN Model Name(s) are NISSAN trademarks.